

*Body-Solid®*



**Table of Contents**

Total Body Workout DVD ..... p. 2  
 Reference Drawings ..... p. 3  
 Safety Instructions ..... p. 4  
 Before You Begin ..... p. 5  
 Dimensions ..... p. 6  
 Safety Guidelines ..... p. 7  
 Preparations ..... p. 8  
 Assembly Instructions ..... p. 9-27  
 Cable Installations ..... p. 28-37  
 Shroud Installation ..... p. 40-41  
 Cable Adjustments ..... p. 38-39  
 Adjustments ..... p. 42-45  
 Warning, Safety & Maintenance ..... p. 46-47  
 Maintenance Schedule ..... p. 48-49  
 Phrases, Terms, Tips & Guidelines . . . p. 50-51  
 Nutrition ..... p. 52  
 Exercise Prescription ..... p. 53  
 Training Tips ..... p. 54  
 Common Training Mistakes ..... p. 55  
 Setting Up Your Personal Program ..... p. 56  
 Determine Your Training Method ..... p. 57  
 Exercise Tips ..... p. 58  
 Anatomy Chart ..... p. 59  
 Fitness Goals ..... p. 60  
 Exercise Logs ..... p. 61-63  
 Stretching & Flexibility ..... p. 64  
 Stretching: Warm-Up / Cool-Down . . . p. 65-69  
 Workout/Exercises ..... p. 70-75  
 Signs of Overtraining ..... p. 76  
 Weight Ratios ..... p. 77  
 Obtaining Service ..... p. 79  
 Mainframe Parts List ..... p. 80-81  
 Hardware Parts List ..... p. 82-85  
 Hardware Diagrams ..... p. 86-88  
 Exploded View Diagram ..... p. 89-90

Sport-Thieme GmbH  
 Helmstedter Straße 40  
 38368 Grasleben  
 Telefon: +49 (0) 5357 181-81  
 Fax: +49 (0) 5357 181 90  
 info@sport-thieme.de  
 www.sport-thieme.de

A s s e m b l y & I n s t r u c t i o n s

**O W N E R ' S & M A N U A L**

# Total Body Workout DVD

Follow the lead of international fitness presenter Geoff Bagshaw as he guides you step by step through a total health and conditioning program. Includes thorough explanations and demonstrations of over 50 exercises targeting all major muscle groups. The Body-Solid Total Body Workout is a “must have” for anyone truly serious about in-home training.



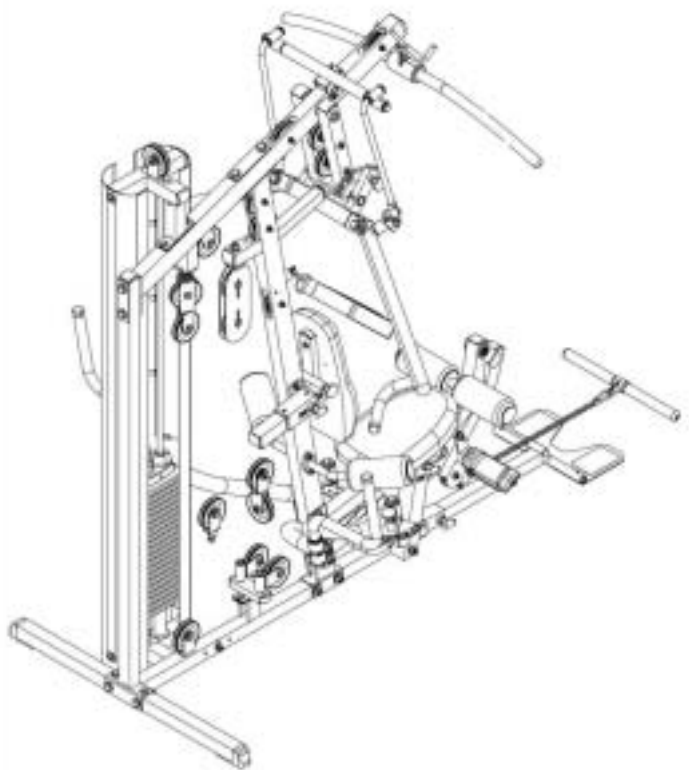
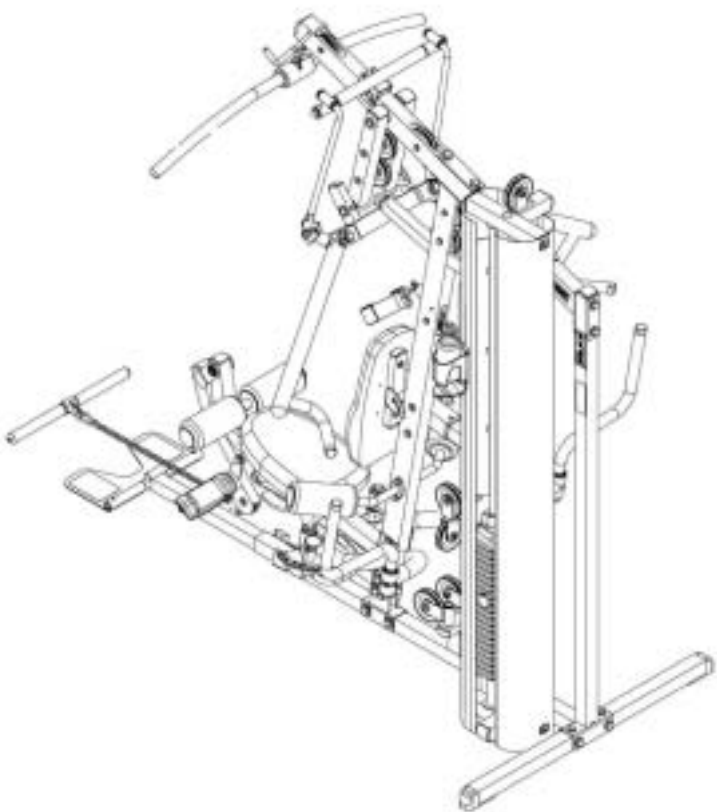
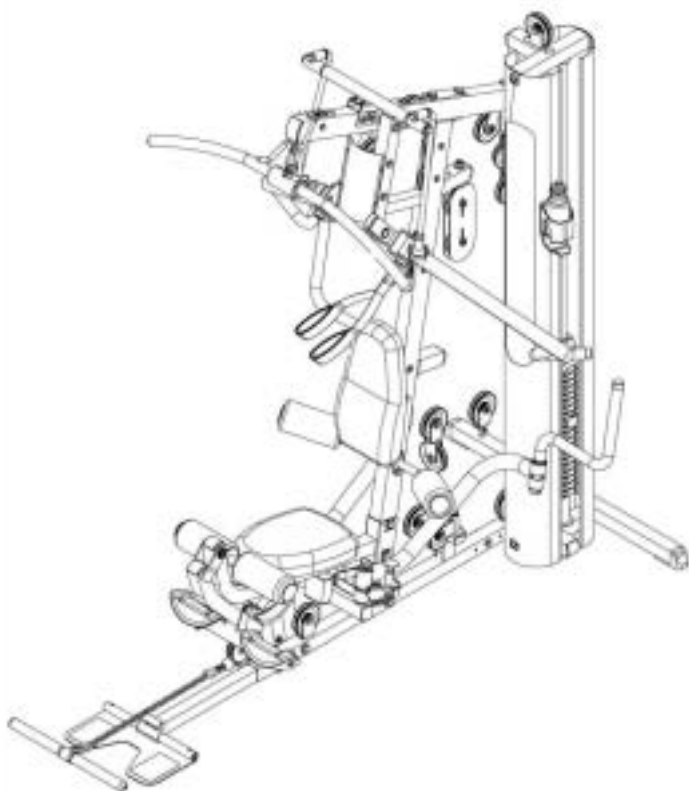
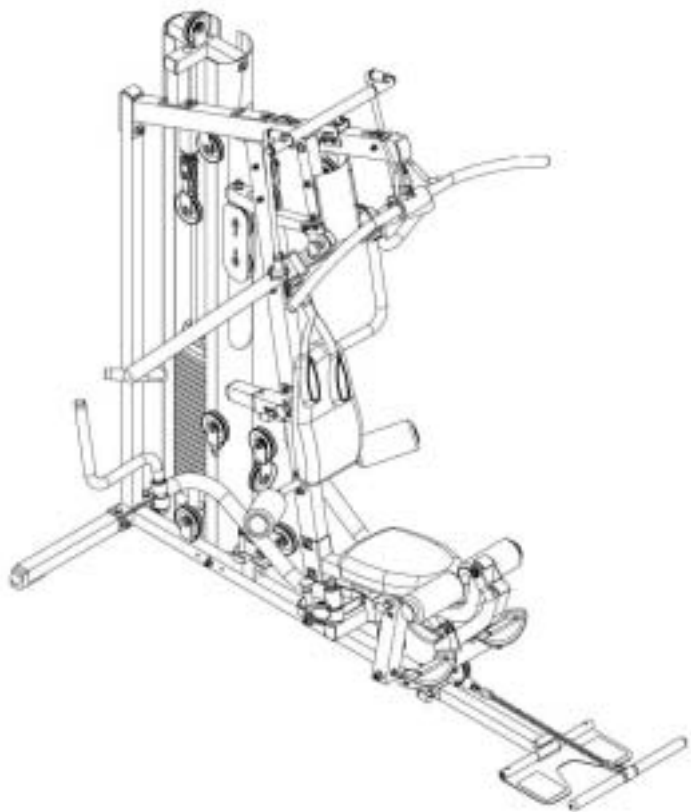
Also includes:

- Complete stretching routine
- Importance of cardio training
- Body-Solid company profile

*Body-Solid*

**Total Body Workout DVD**

**G 6 B**  
Reference Drawings



# Important Safety Instructions

Before beginning any fitness program, you should obtain a complete physical examination from your physician.

*Il est conseillé de subir un examen médical complet avant d'entreprendre tout programme d'exercice.  
Si vous avez des étourdissements ou des faiblesses, arrêtez les exercices immédiatement.*

*Antes de comenzar cualquier programa de ejercicios, deberías tener un examen físico con su doctor.*

---

## **When using exercise equipment, you should always take basic precautions, including the following:**

- Read all instructions before using the G6B. These instructions are written to ensure your safety and to protect the unit.
- Do not allow children on or near the equipment.
- Use the equipment only for its intended purpose as described in this guide. Do not use accessory attachments that are not recommended by the manufacturer. Such attachments might cause injuries.
- Wear proper exercise clothing and shoes for your workout, no loose clothing.
- Use care when getting on or off the unit.
- Do not overexert yourself or work to exhaustion.
- If you feel any pain or abnormal symptoms, stop your workout immediately and consult your physician.
- Never operate unit when it has been dropped or damaged. Return the equipment to a service center for examination and repair.
- Never drop or insert objects into any opening in the equipment.
- Always check the unit and its cables before each use. Make sure that all fasteners and cables are secure and in good working condition.
- Do not use the equipment outdoors or near water.

## **Personal Safety During Assembly**

- It is strongly recommended that a qualified dealer assemble the equipment. **Assistance is required.**
- Before beginning assembly, please take the time to read the instructions thoroughly.
- Read each step in the assembly instructions and follow the steps in sequence. Do not skip ahead. If you skip ahead, you may learn later that you have to disassemble components and that you may have damaged the equipment.
- Assemble and operate the G6B on a solid, level surface. Locate the unit a few feet from the walls or furniture to provide easy access.

The G6B is designed for your enjoyment. By following these precautions and using common sense, you will have many safe and pleasurable hours of healthful exercise with your Body-Solid G6B.

After assembly, you should check all functions to ensure correct operation. If you experience problems, first recheck the assembly instructions to locate any possible errors made during assembly. If you are unable to correct the problem, call the dealer from whom you purchased the machine or call 1-800-833-1227 for the dealer nearest you.

## **Obtaining Service**

Please use this Owner's Manual to make sure that all parts have been included in your shipment. When ordering parts, you must use the part number and description from this Owner's Manual. Use only Body-Solid replacement parts when servicing this machine. Failure to do so will void your warranty and could result in personal injury.

For information about product operation or service, check out the official Body-Solid website at [www.bodysolid.com](http://www.bodysolid.com) or contact an authorized Body-Solid dealer or a Body-Solid factory-authorized service company or contact Body-Solid customer service at one of the following:

Toll Free: 1-800-556-3113  
Phone: 1-708-427-3555 ext. 5  
Fax: 1-708-427-3598  
E-mail: [service@bodysolid.com](mailto:service@bodysolid.com)

Or write to: Body-Solid, Inc.  
Service Department  
1900 S. Des Plaines Ave.  
Forest Park, IL 60130 USA

**Retain this Owner's Manual for future reference. Part numbers are required when ordering parts.**

## **B e f o r e   Y o u   B e g i n**

Thank you for purchasing the G6B. This gym is part of the Body-Solid line of quality strength training machines, which let you target specific muscle groups to achieve better muscle tone and overall body conditioning. To maximize your use of the equipment please study this Owner's Manual thoroughly.

---

### **Unpacking the Equipment**

The G6B is carefully tested and inspected before shipment. Body-Solid ships the unit in several pieces that require assembly. Ask for assistance during the assembly process.

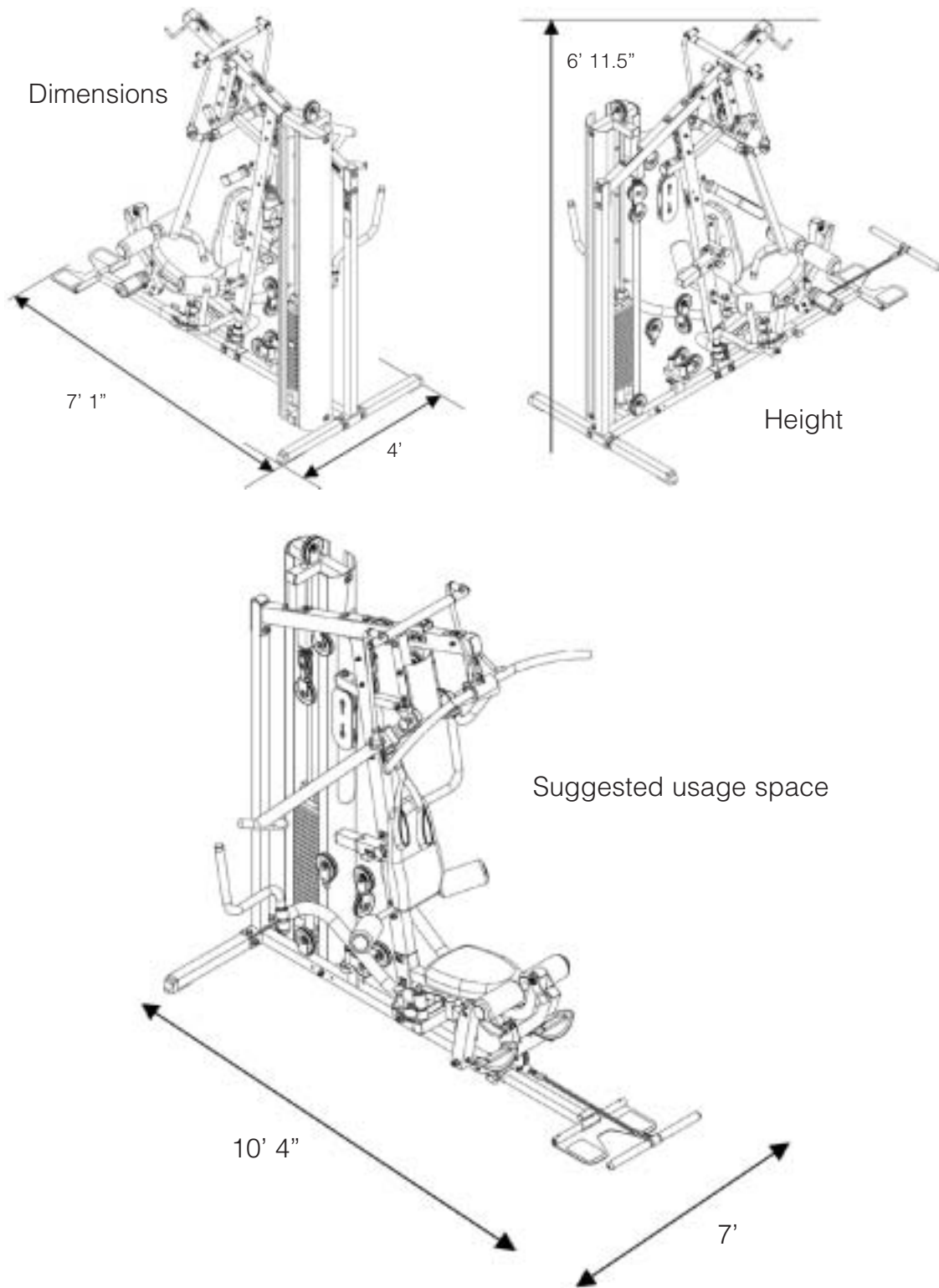
Carefully unpack the boxes and lay the pieces on the floor near the area where you plan to use the equipment.

***Be careful to assemble all components in the sequence presented in this guide.***

If any items are missing, contact the dealer from whom you purchased the unit or call 1-800-833-1227 for the dealer nearest you.

# Dimensions

The room layout diagram below will help you decide the best placement for your G6B. The dimensions of the G6B are: width 4' X length 7'1". The ceiling height requirement for the G6B is 7'. The usage space is: width 7' X length 10' 4" (The usage space is the overall space needed for operation.) The usage space needed for the G6B could be more, depending on the user, allow enough room for the Low Row Station.



# S a f e t y   G u i d e l i n e s

Successful resistance training programs have one prominent feature in common...safety. Resistance training has some inherent dangers, as do all physical activities. The chance of injury can be greatly reduced or completely removed by using correct lifting techniques, proper breathing, maintaining equipment in good working condition, and by wearing the appropriate clothing.

---

- 1. It is highly recommended that you consult your physician before beginning any exercise program. This is especially important for individuals over the age of 35, or persons with pre-existing health problems.**
- 2. Always warm up before starting a workout. Try to do a total body warm up before you start. It is especially important to warm up the specific muscle groups you are going to be using. This can be as simple as performing a warm up set of high repetitions and light weight for each exercise.**
- 3. Use proper form. Focus on only working the muscle groups intended for the exercise you are doing. If there is strain elsewhere, you may need to re-evaluate the amount of weight that is involved with the lift. Keeping proper form also includes maintaining control through the entire range of motion.**
- 4. Breathe properly. Inhale during the eccentric phase of the exercise, and exhale during the lifting, or concentric phase. Never hold your breath during any part of an exercise.**
- 5. Always wear the appropriate clothing and shoes when exercising. Wearing comfortable athletic shoes with good support and suitable, breathable clothing will reduce the risk of injury.**
- 6. Maintaining equipment in proper operating condition is of utmost importance for a safe resistance training program. Pulleys and cables should be checked for wear frequently and replaced as needed. Equipment should be lubricated as indicated by the manufacturer.**
- 7. Read and study all warning labels on this machine. It is absolutely necessary that you familiarize yourself and all others with the proper operation of this machine prior to use.**
- 8. Keep hands, limbs, loose clothing and long hair well out of the way of all moving parts.**
- 9. Do not attempt to lift more weight than you can control safely.**
- 10. Inspect the machine daily for loose or worn parts. If a problem is found do not allow the machine to be used until all parts are tightened or worn or defective parts are repaired or replaced.**

# Preparations

**CAUTION: To set up this unit, you will need assistance. Do not attempt assembly by yourself.**

You must review and follow the instructions in this Owner's Manual. If you do not assemble and use the G6B according to these guidelines, you could void the Body-Solid warranty.

## Required Tools

The tools that you must obtain before assembling the G6B include:

- 3mm Allen Key
- 4mm Allen Key
- 5mm Allen Key
- 6mm Allen Key
- 8mm Allen Key
- 9/16" Open-End Wrench
- 11/16" Open-End Wrench
- 13/16" Open-End Wrench
- 3/4" Open-End Wrench
- 9/16" Box Wrench
- 11/16" Box Wrench
- 13/16" Box Wrench
- 3/4" Box Wrench

**CAUTION: Obtain assistance! Do not attempt to assemble the G6B by yourself. Review the Installation Requirements before proceeding with the following steps.**

The G6B unit comes in eight boxes. Be careful to assemble components in the sequence presented in this guide.

NOTE: With so many assembled parts, proper alignment and adjustment is critical. While tightening the nuts and bolts, be sure to leave room for adjustments.

## Installation Requirements

Follow these installation requirements when assembling the G6B:

Set up the G6B on a solid, flat surface. A smooth, flat surface under the machine helps keep it level. A level machine has fewer malfunctions.

Provide ample space around the machine. Open space around the machine allows for easier access.

Insert all bolts in the same direction. For aesthetic purposes, insert all bolts in the same direction unless specified (in text or illustrations) to do otherwise.

Leave room for adjustments. Tighten fasteners such as bolts, nuts, and screws so the unit is stable, but leave room for adjustments. Do not fully tighten fasteners until instructed in the assembly steps to do so.

Fill out and mail warranty card.



# Assembly Instructions

Assembly of the G6B takes professional installers about 3 hours to complete. If this is the first time you have assembled this type of equipment, plan on significantly more time.

## Professional installers are highly recommended!

However, if you acquire the appropriate tools, obtain assistance, and follow the assembly steps sequentially, the process will take time, but is fairly easy.

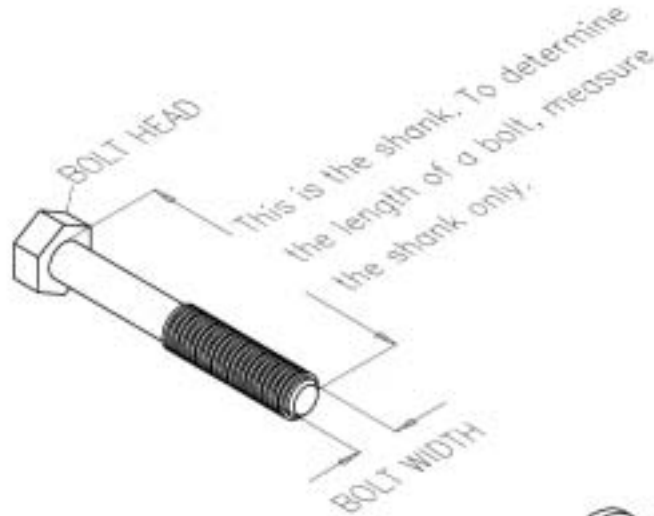
### Assembly Tips

Read all "Notes" on each page before beginning each step.

While you may be able to assemble the G6B using the illustrations only, important safety notes and other tips are included in the text.

Some pieces may have extra holes that you will not use. Use only those holes indicated in the instructions and illustrations.

NOTE: To find out the length of a particular bolt, measure its shank (the long, narrow part beneath the head). Refer to the following diagram:



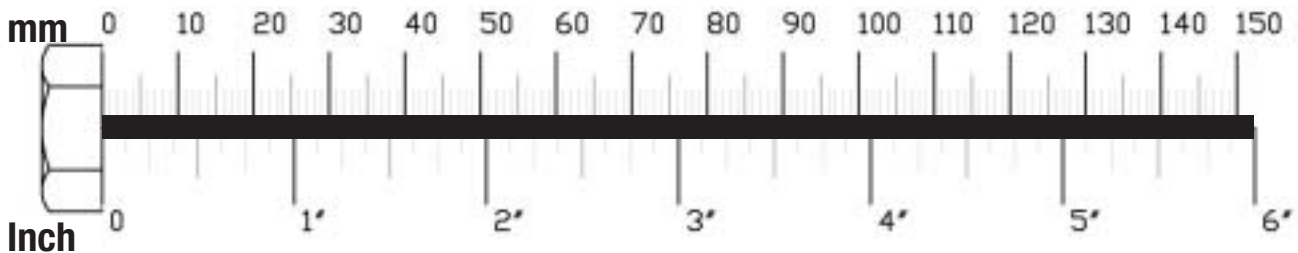
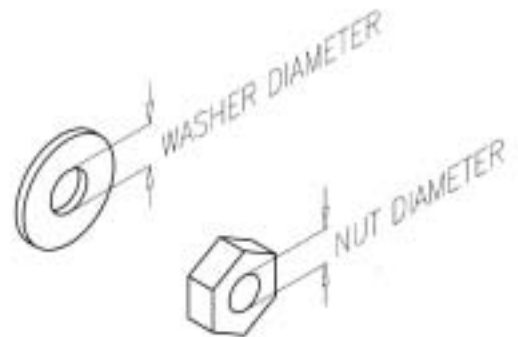
### IMPORTANT!

Before you begin you should fold-out pages 86, 87 and 88.

This is a quick reference guide that shows all hardware parts (in actual size) along with the corresponding key numbers on the assembly instructions.

**Do not fully tighten bolts until instructed to do so.**

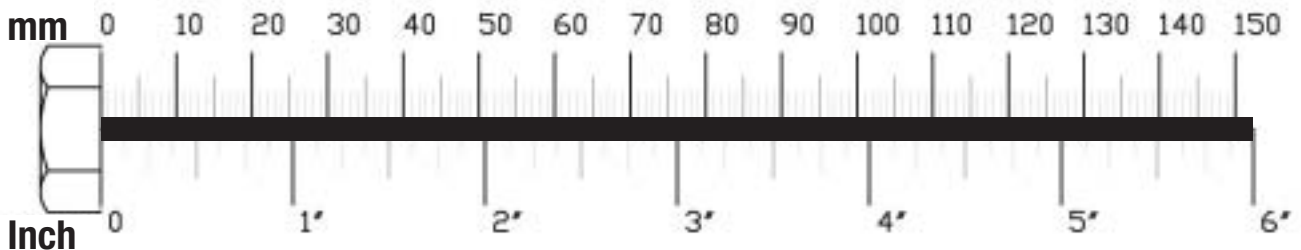
**Note:** After assembly, you should check all functions to ensure correct operation. If you experience problems, first recheck the assembly instructions to locate any possible errors made during assembly. If you are unable to correct the problem, call the dealer from whom you purchased the machine or call 1-800-833-1227 for the dealer nearest you.

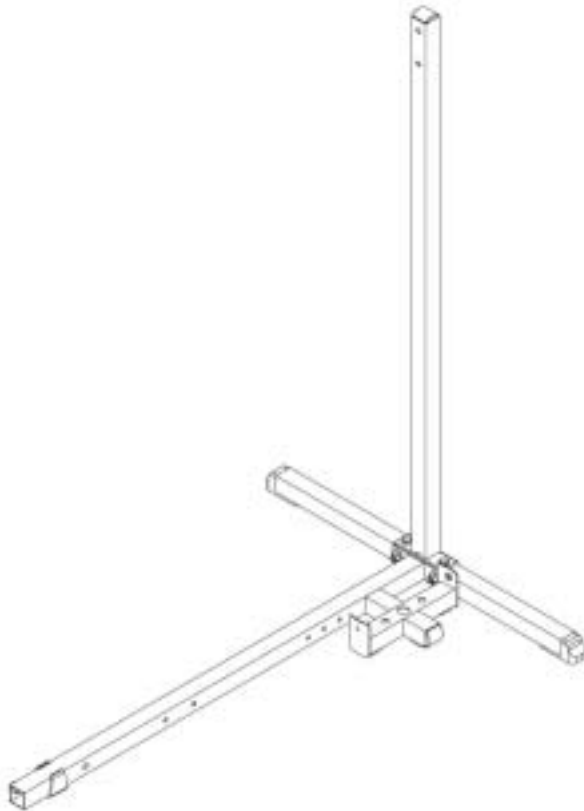


**STEP****1****Be careful to assemble all components in the sequence they are presented.****NOTE:**

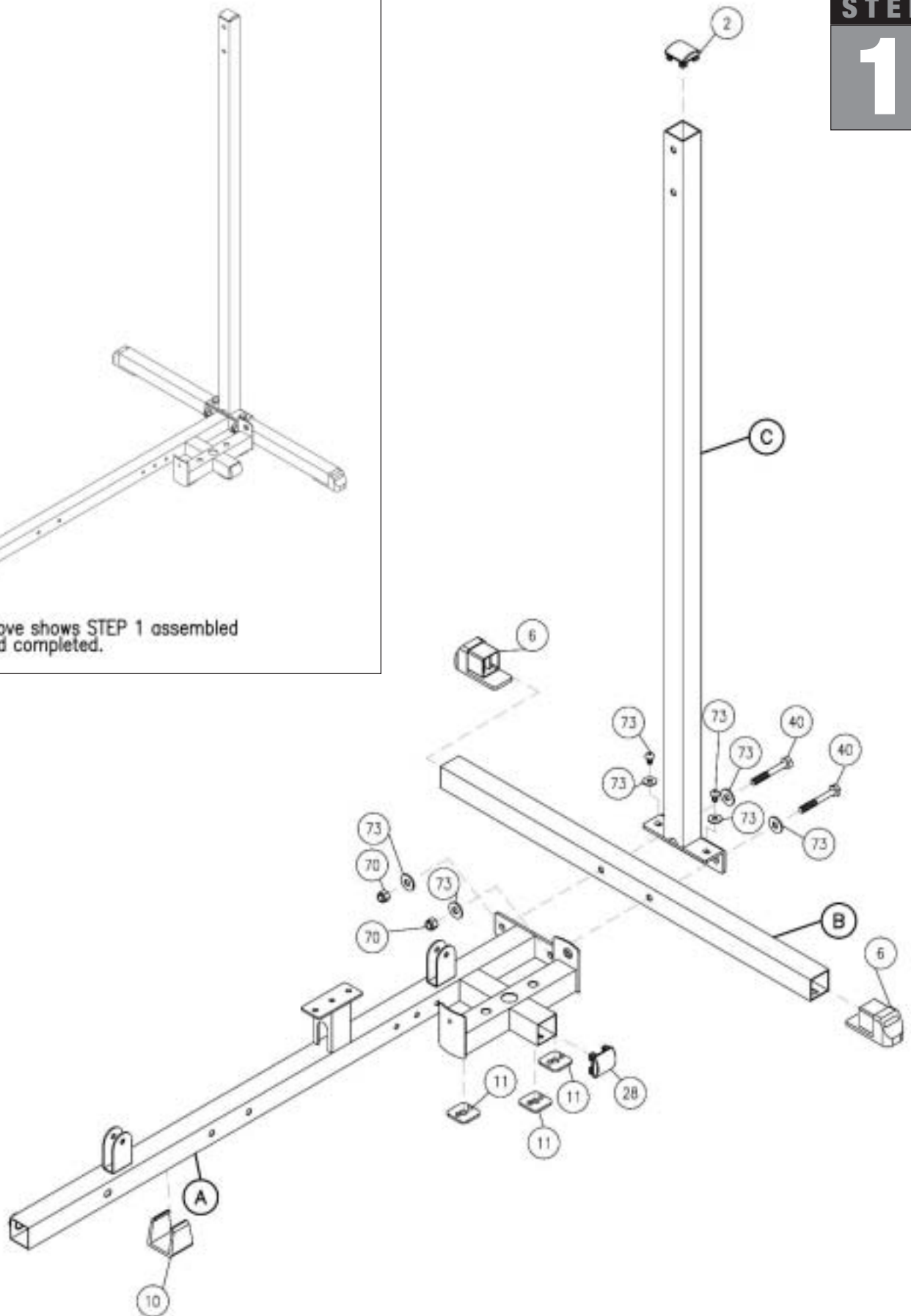
Finger tighten all hardware in this step. Do Not wrench tighten until end of step 3.

- A. Attach Frame Leveler (10) to Main Base Frame (A) as shown.  
Insert two Weight Stack Shims (11) to Main Base Frame (A) as shown.  
Insert Convex End Cap (28) to the opening in Main Base Frame (A) as shown.
- B. Attach Main Base Frame (A) to Rear Base Frame (B) and Rear Vertical Frame (C) using:  
**Two 40 (1/2" x 3 1/4" hex head bolt)**  
**Four 73 (1/2" washer)**  
**Two 70 (1/2" nylon lock nut)**  
Also use:  
**Two 55 (3/8" x 2 3/4" hex head bolt)**  
**Two 74 (3/8" washer)**  
**Two 71 (3/8" nylon lock nut)**
- C. Insert two Foot Caps (6) to the ends of Rear Base Frame (B).  
Insert Convex End Cap (2) to the top of Rear Vertical Frame (C) as shown.





Above shows STEP 1 assembled and completed.



**STEP****2**

**Be careful to assemble all components in the sequence they are presented.**

**NOTE:**

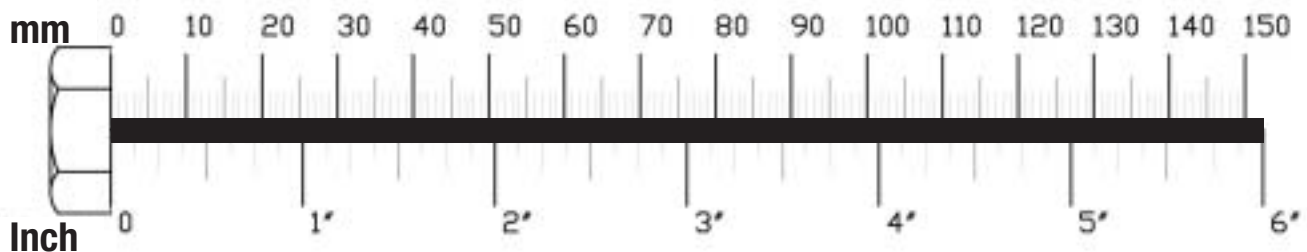
Finger tighten all hardware in this step. Do Not wrench tighten until end of step 3.

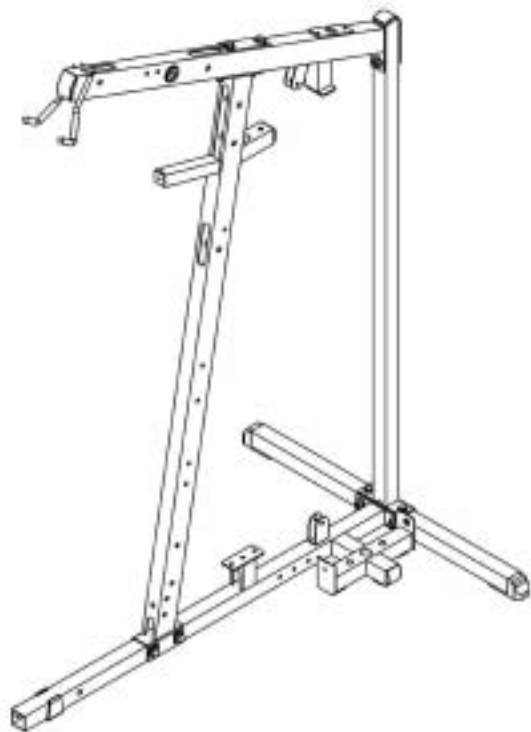
- A. Attach Angled Support Frame (D) to Main Base Frame (A) using:  
**Two 40 (1/2" x 3 1/4" hex head bolt)**  
**Four 73 (1/2" washer)**  
**Two 70 (1/2" nylon lock nut)**
- B. Insert Convex End Cap (4) to the front of the Top Frame (E).  
Attach Top Frame (E) and Plate (67) to the Rear Vertical Frame (C) using:  
**Two 40 (1/2" x 3 1/4" hex head bolt)\***  
**Three 73 (1/2" washer)**  
**One 70 (1/2" nylon lock nut)**

**\*NOTE:**

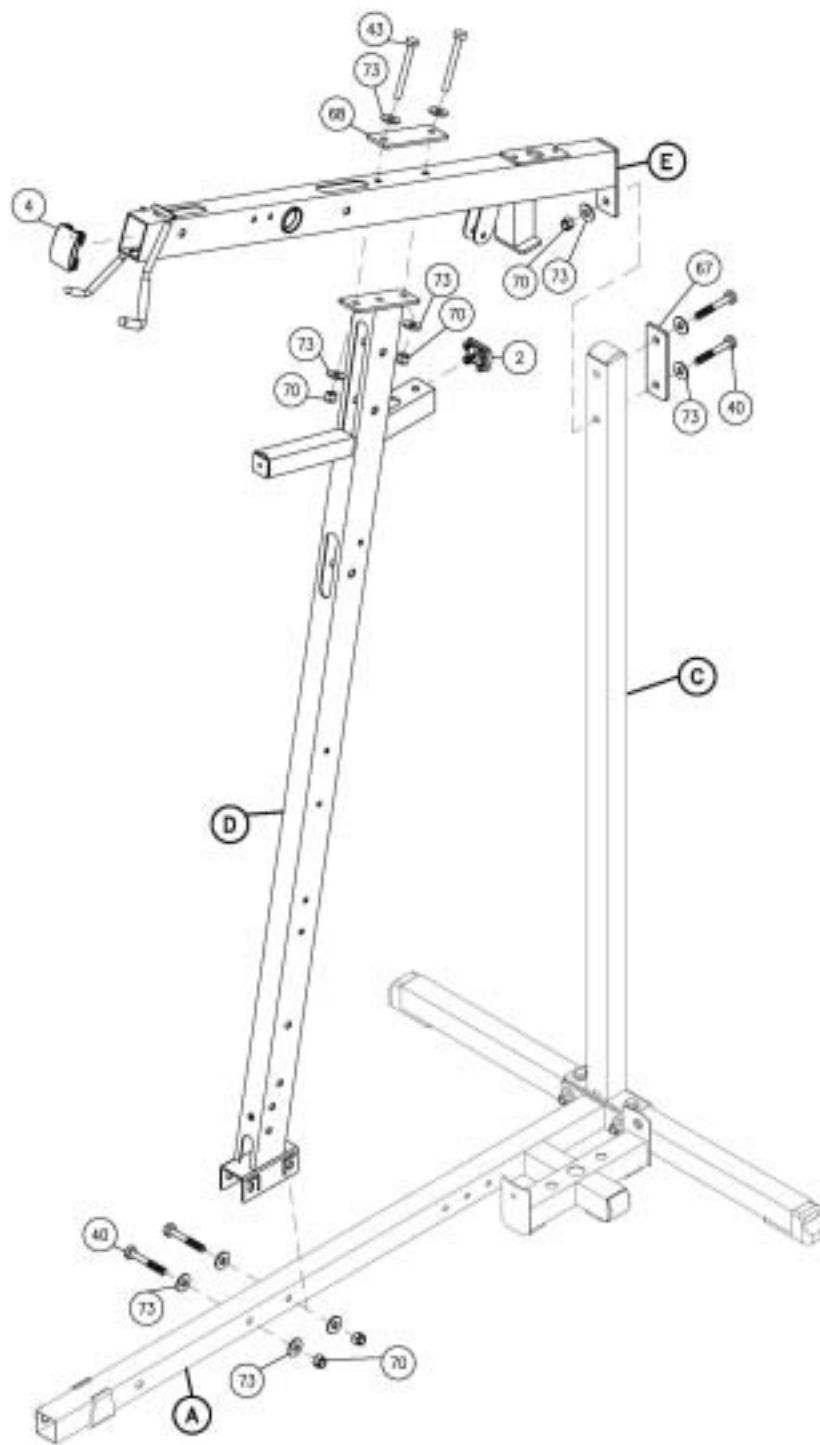
**One bolt (40) goes into an internally threaded nut inside Top Frame (E).**

- C. Attach Top Frame (E) and Plate (68) to Angled Support Frame (D) using:  
**Two 43 (1/2" x 4 1/4" hex head bolt)**  
**Four 73 (1/2" washer)**  
**Two 70 (1/2" nylon lock nut)**
- D. Insert Convex End Cap (2) to the small horizontal arm on Angled Support Frame (D) as shown.





Above shows STEP 2 assembled and completed.



**STEP****3****Be careful to assemble all components in the sequence they are presented.****NOTE:**

**At this point you must make sure that the gym is level, stable and in the right location.**

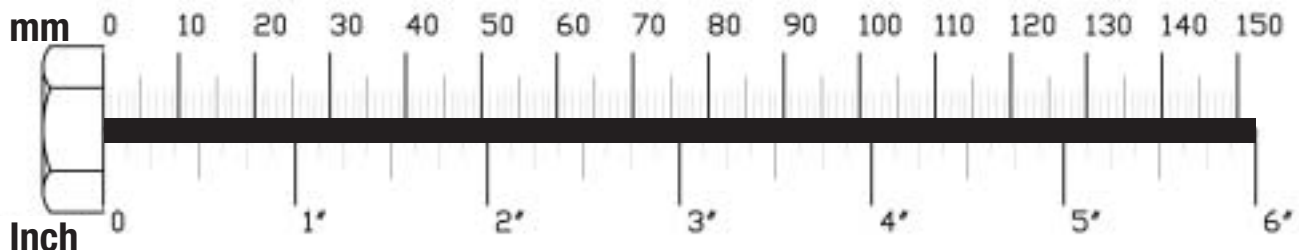
- A. Place two Weight Stack Risers (36) and two Rubber Donuts (14) onto Main Base Frame (A) as shown. Slide two Guide Rods (F) through the Rubber Donuts (14), through the two Weight Stack Risers (36), and into the Main Base Frame (A).
- B. Slide Weight Stack Plates (37)\* onto Guide Rods (F). Make sure the opening in each Weight Stack Plate (37), for the Weight Stack Pin (81), is facing outward.

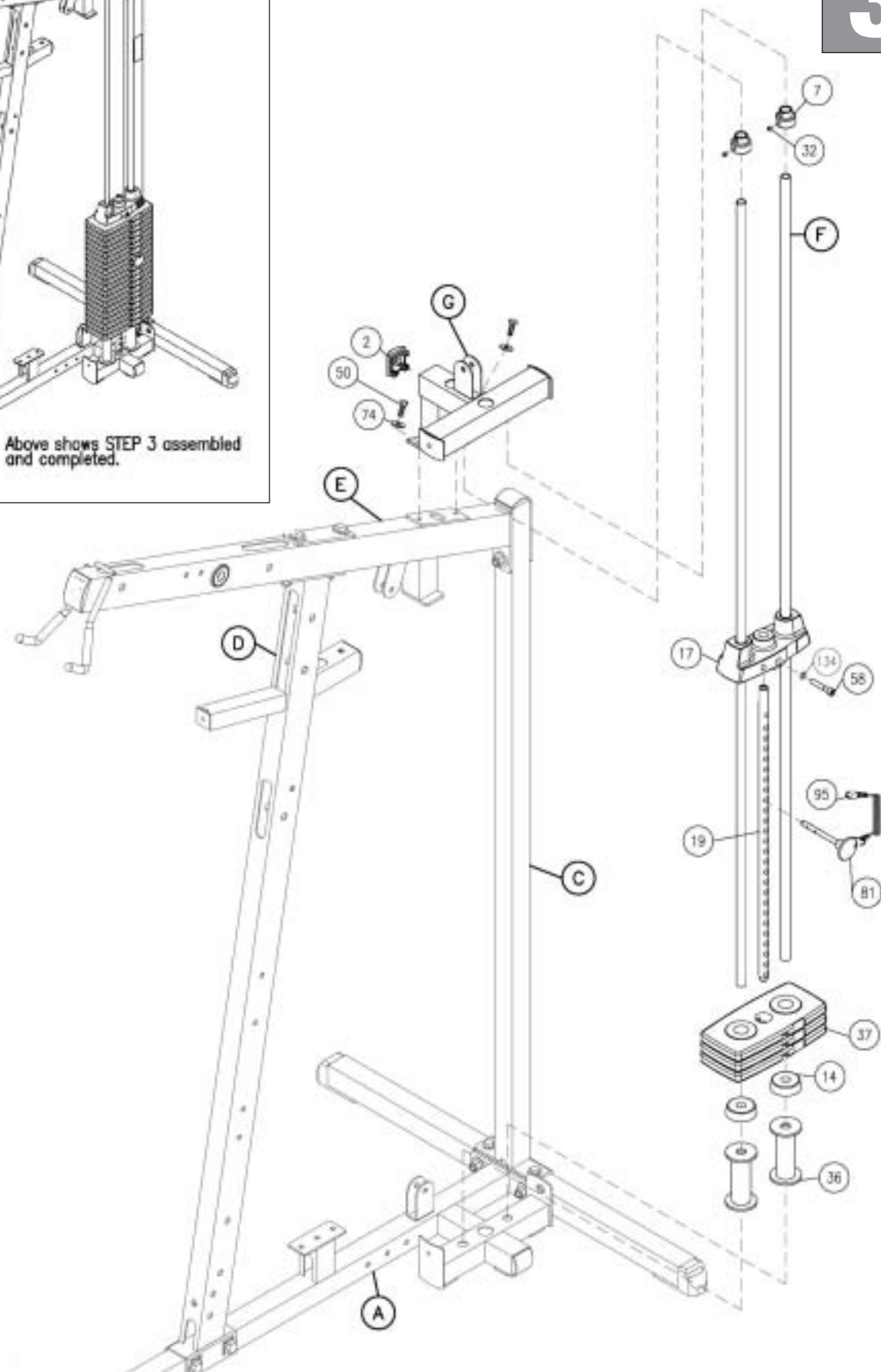
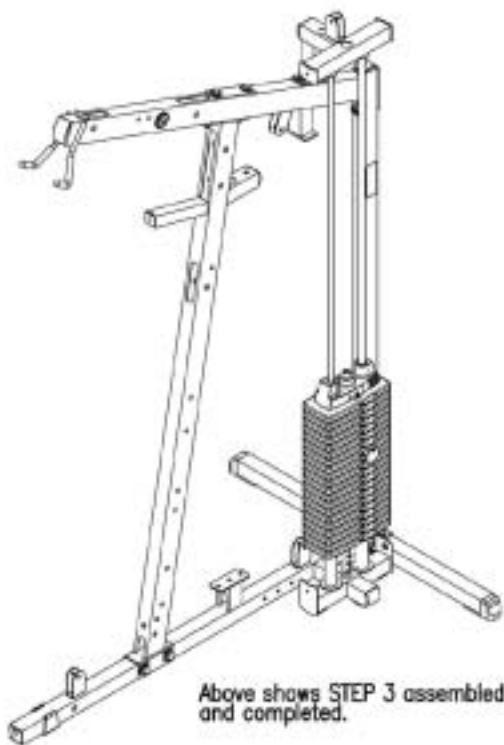
**\*NOTE:**

**Use fifteen 10lb. plates for a 160lb. weight stack.**

**Use twenty 10lb. plates for a 210lb. weight stack. See NOTE after Step 1B.**

- C. Connect Top Plate (17) to the Selector Rod (19) using:  
**One 58 (3/8" x 2" round allen head)**  
**One 134 (3/8" spring lock washer)**  
Slide Top Plate (17) and Selector Rod (19) onto Guide Rods (F).
- D. Slide two Shaft Collars (7) onto the two Guide Rods (F) as shown.
- E. Insert Guide Rods (F) into Top Weight Stack Frame (G), and Attach Top Weight Stack Frame (G) to Top Frame (E) using:  
**Two 50 (3/8" x 1" hex head bolt)**  
**Two 74 (3/8" washer)**  
Attach Convex End Cap (2) to Top Weight Stack Frame (G) as shown.
- F. Slide Shaft Collars (7) up into the Top Weight Stack Frame (G) and turn the Shaft Collar, so it locks onto the Top Weight Stack Frame (G), Now tighten each Allen Screw (32) in Shaft Collars (7).
- G. You can now wrench tighten all bolts and nuts on the main frame unit.



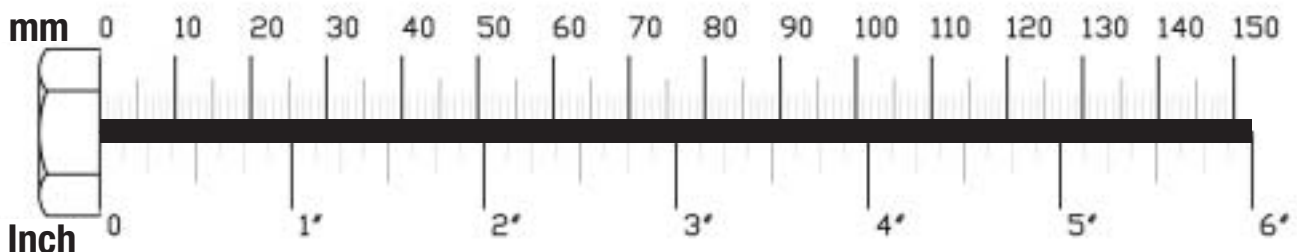


**STEP****4**

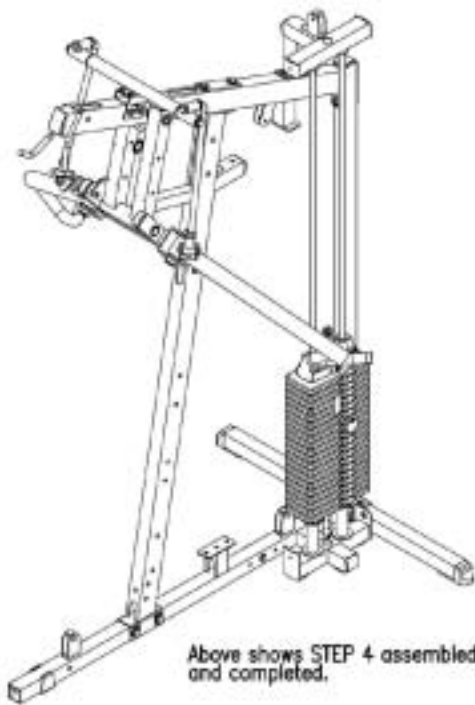
**Be careful to assemble all components in the sequence they are presented.**

- A. Attach two Convex End Caps (2) to the top of Seated Press Arm Support (H). Attach Seated Press Arm Support (H) to Top Frame (E) using Shaft (33), and tighten Allen Screws (34).
- B. Attach Bi Angular Bars (J) to Top Frame (E) using:  
**Two 53 (3/8" x 3" hex head bolt)**  
**Four 74 (3/8" washer)**  
**Two 71 (3/8" nylon lock nut)**  
Also using:  
**Two 80 (3/8" x 1/2" hex head bolt)**  
**Two 79 (3/8" washer)**
- C. Attach Press Arm Holder (K) to Seated Press Arm Support (H) using Shaft (35), and tighten Allen Screws (34).
- D. Attach Left Press Arm (L) to Press Arm Holder (K) using Shaft (KA), and:  
**One 37 (1/2" x 3/4" hex head bolt)**  
**One 73 (1/2" washer)**  
And tighten Allen Screws (34).
- E. Attach Right Press Arm (M) to Press Arm Holder (K) using Shaft (KB), and:  
**One 37 (1/2" x 3/4" hex head bolt)**  
**One 73 (1/2" washer)**  
And tighten Allen Screws (34).
- F. Connect Bi Angular Bars (J) to Left Press Arm (L) using Shaft (39) and:  
**Two 74 (3/8" washer)**  
**Two 36 (3/8" x 5/8" round allen bolt)**
- G. Connect Bi Angular Bars (J) to Right Press Arm (M) using Shaft (39) and:  
**Two 74 (3/8" washer)**  
**Two 36 (3/8" x 5/8" round allen bolt)**

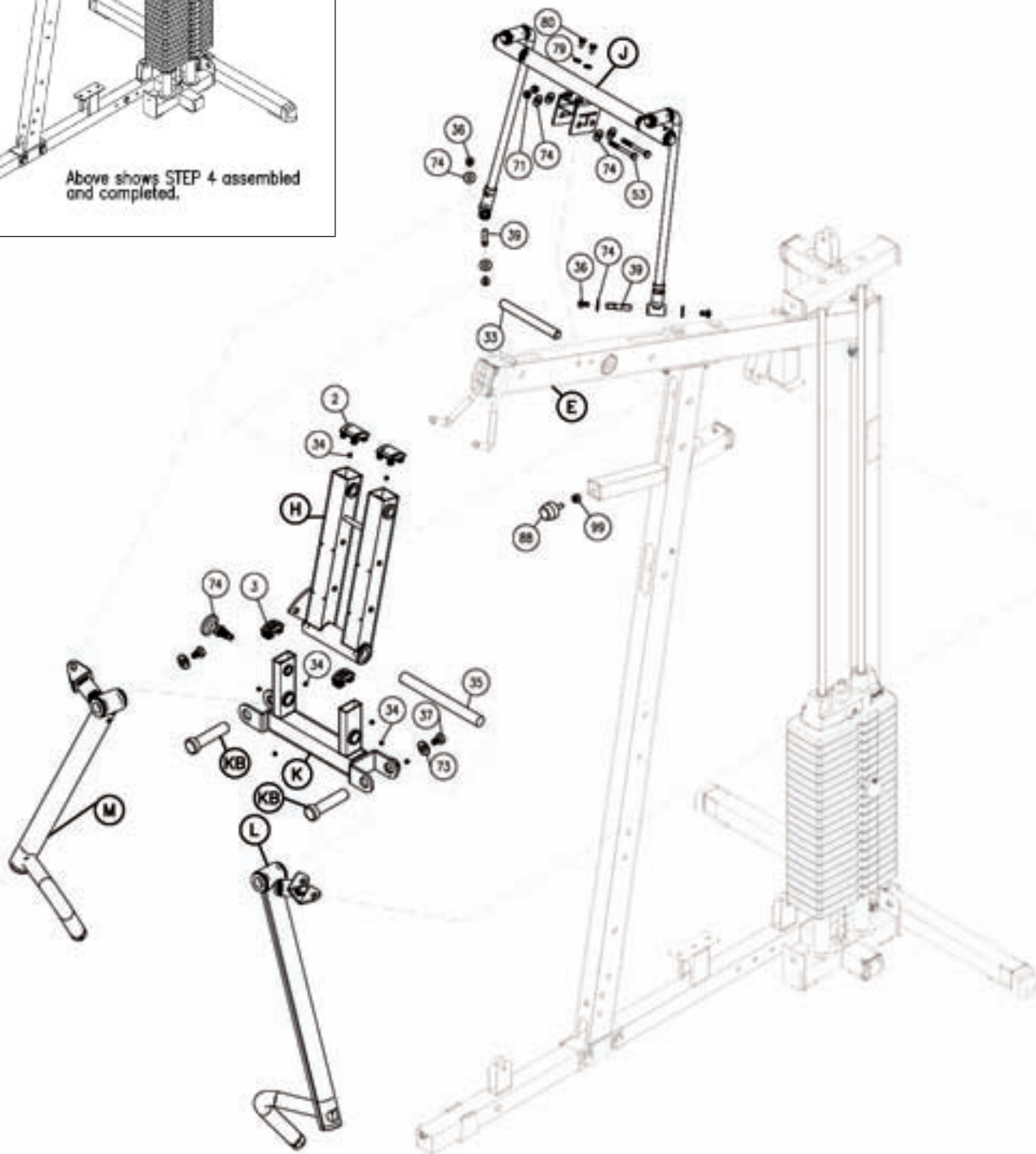
**Note:**  
You should now wrench tighten all bolts and nuts in this step.







Above shows STEP 4 assembled and completed.



**STEP****5**

**Be careful to assemble all components in the sequence they are presented.**

- A. Attach Pec Dec Frame (N) to Angled Support Frame (D) in the bottom two holes as shown using:  
**One 42 (1/2" x 3 3/4" hex head bolt)\***  
**Two 43 (1/2" x 3 1/4" hex head bolt)**  
**Five 73 (1/2" washer)**  
**Two 70 (1/2" nylon lock nut)**

Attach two End Caps (15) to the top and bottom of the Pec Dec Frame (N) as shown.  
 Attach two Convex End Caps (2) to the sides of the Pec Dec Frame (N) as shown.

**\*Note:**

**Hex Head Bolt (42) goes into an internally threaded nut inside Pec Dec Frame (N).**

- B. Slide Oilite Washer (26), Left Pec Dec Cam (P) and then the Left Pec Dec Arm (Q) onto the left side of the Pec Dec Frame (N) as shown, Attach using:  
**One 37 (1/2" x 3/4" hex head bolt)**  
**One 73 (1/2" washer)**

- C. Attach Left Pec Dec Handle (R)\* to the Left Pec Dec Arm (Q) using:

**One 45 (5/16" x 3/4" flat allen head)**  
**One 77 (5/16" spring lock washer)**

Slide Chrome Collar (46) onto the bottom of the Left Pec Dec Handle (R) as shown, and tighten Allen Screw (34).

**\*Note:**

**Left Pec Dec Handle (R) should bend out, away from the the gym.**

- D. Slide Oilite Washer (26), Right Pec Dec Cam (S) and then the Right Pec Dec Arm (T) onto the Right side of the Pec Dec Frame (N) as shown, attach using:

**One 37 (1/2" x 3/4" hex head bolt)**  
**One 73 (1/2" washer)**

- E. Attach Right Pec Dec Handle (U)\* to the Right Pec Dec Arm (T) using:

**One 45 (5/16" x 3/4" flat allen head)**  
**One 77 (5/16" spring lock washer)**

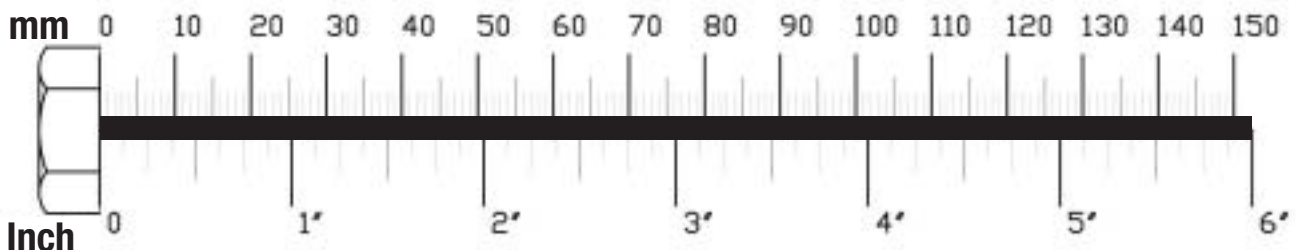
Slide Chrome Collar (46) onto the bottom of the Right Pec Dec Handle (U) as shown, and tighten Allen Screw (34).

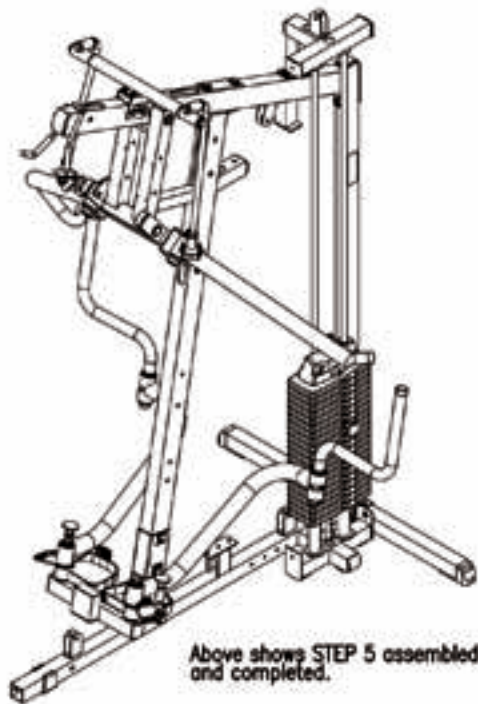
**\*Note:**

**Right Pec Dec Handle (U) should bend out, away from the gym.**

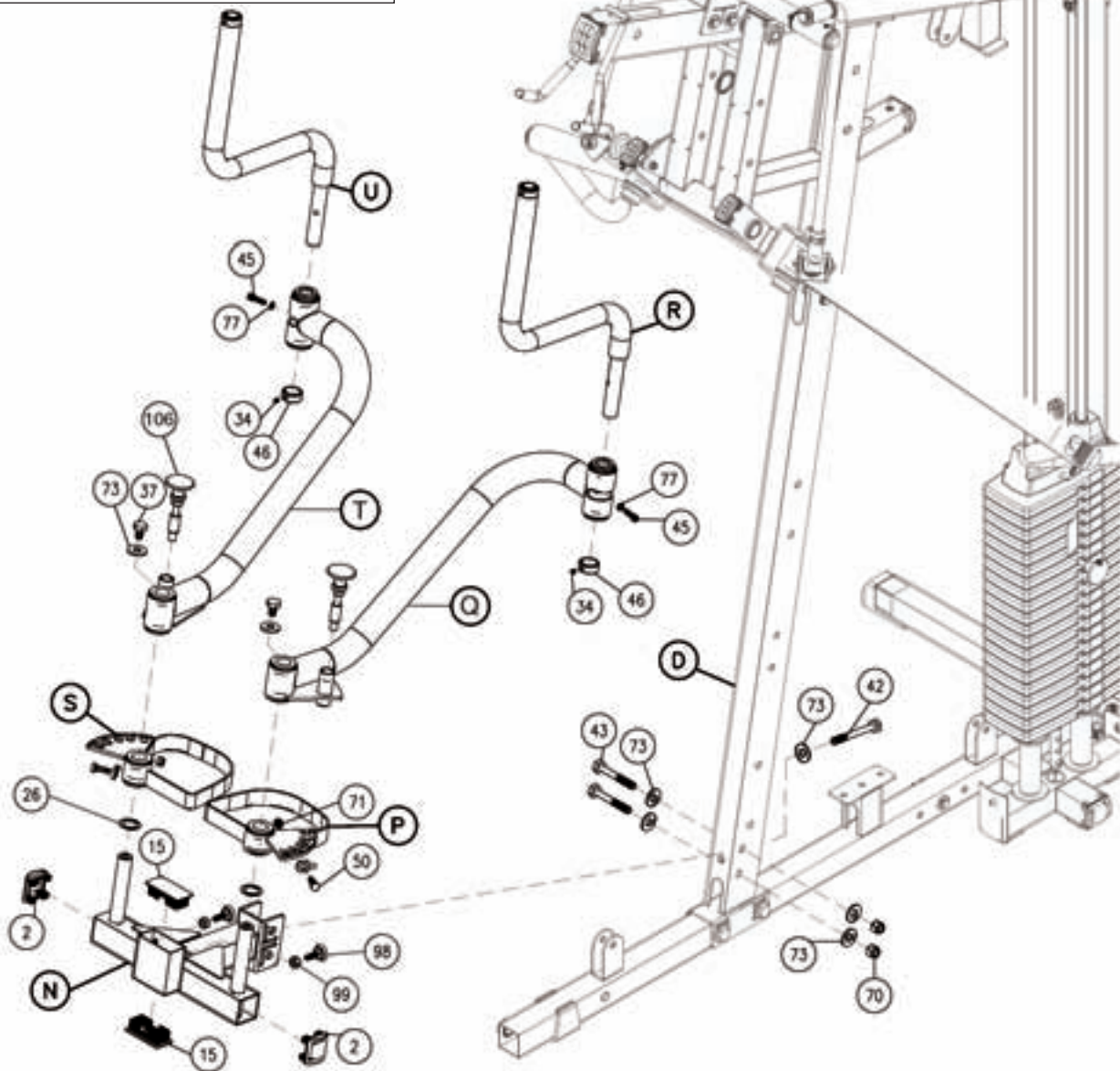
**Note:**

**You should now wrench tighten all bolts and nuts in this step.**





Above shows STEP 5 assembled and completed.



**STEP****6**

**Be careful to assemble all components in the sequence they are presented.**

**NOTE:**

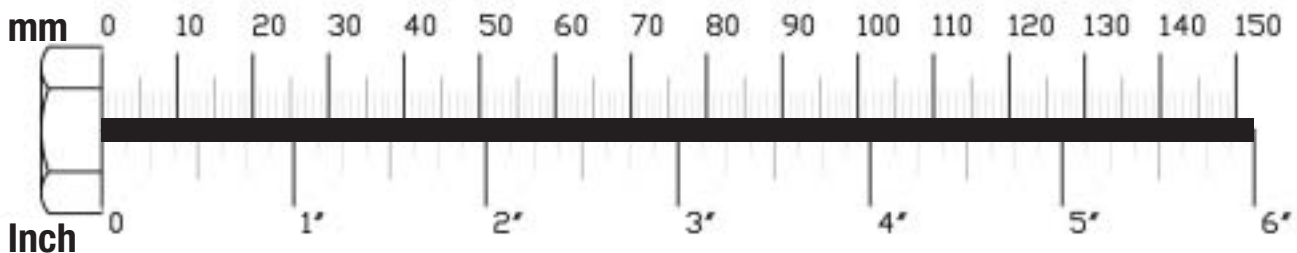
**LEG EXTENSION FRAME (V) AND THE SEAT PAD FRAME (W) ARE PRE-ASSEMBLED AS ONE PIECE.**

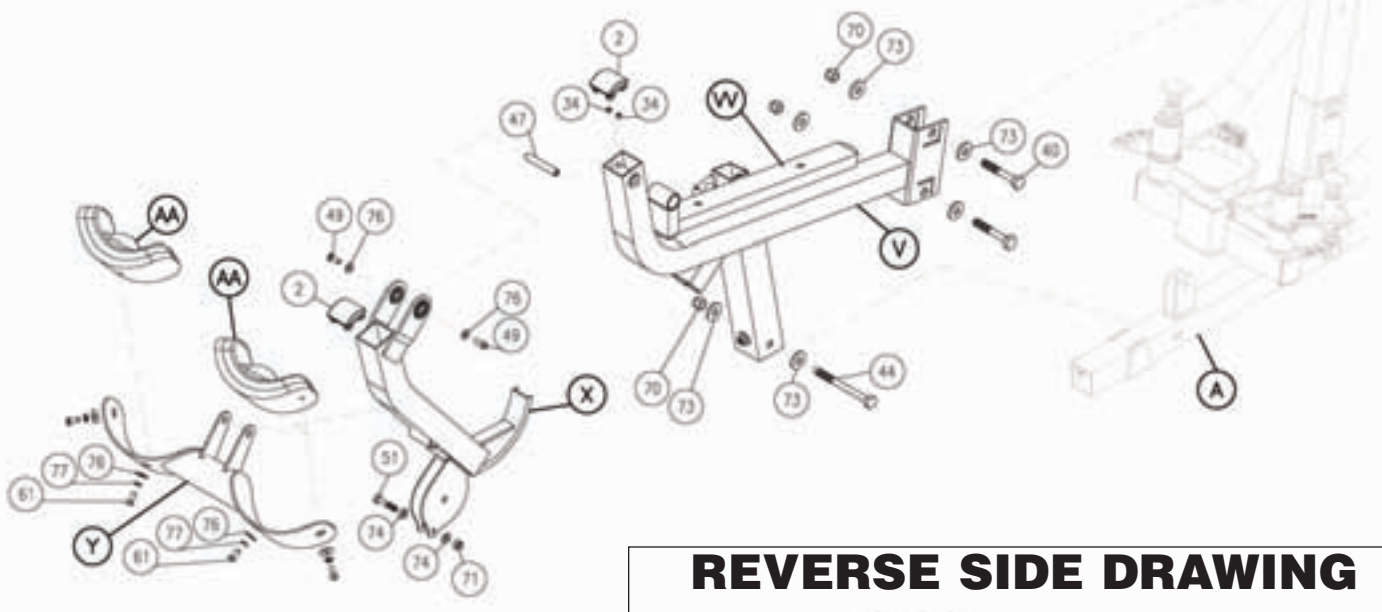
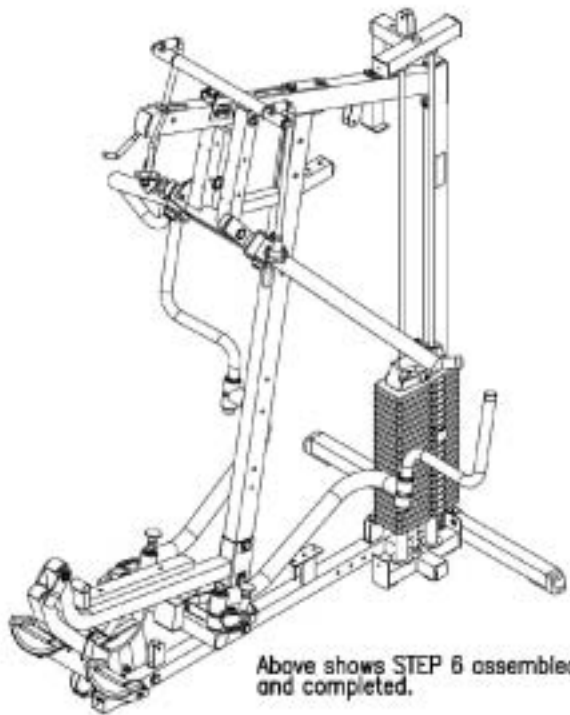
- A. Attach Leg Extension Frame (V) to Angled Support Frame (D) using:  
**Two 40 (1/2" x 3 1/4" hex head bolt)**  
**Four 73 (1/2" washer)**  
**Two 70 (1/2" nylon lock nut)**
- B. Attach the bottom of Leg Extension Frame (V) to Main Base Frame (A) using:  
**One 44 (1/2" x 5 1/2" hex head bolt)**  
**Two 73 (1/2" washer)**  
**One 70 (1/2" nylon lock nut)**
- C. Attach Leg Extension Arm (X) to Leg Extension Frame (V) with pre-installed Shaft (47) as shown using:  
**Two 49 (5/16" x 1/2" round allen head bolt)**  
**Two 76 (5/16" washer)**
- D. Tighten the two Allen Screws (34) to lock down Shaft (47) in Leg Extension Frame (V). Attach two Convex End Caps (2) one to the top of Leg Extension Frame (V) and one to the top of the Leg Extension Arm (X) as shown.
- E. Attach Lock Down Hook (152) to Leg Extension Frame (V) as shown in the REVERSE SIDE DRAWING using:  
**One 57 (3/8" x 2 1/2" hex head bolt)**  
**Two 73 (1/2" washer)**  
**One 153 (5/16" wide spacer)**
- F. Attach Leg Extension Pad Holder (Y) and 1/4" Wide Spacer (154) to Leg Extension Arm (X) using:  
**One 150 (1/2" x 4 1/2" hex head bolt)**  
**Three 73 (1/2" washer)**  
**One 70 (1/2" nylon lock nut)**
- G. Attach Leg Pads (AA) to Leg Extension Pad Holder (Y) using:  
**Four 61 (5/16" x 3/4" round allen head bolt)\***  
**Four 77 (5/16" spring lock washer)**  
**Four 76 (5/16" washer)**

**\*Do NOT over-tighten these bolts. Tighten these bolts until spring lock washer is flat. Over - tightening these bolts will cause T - nuts in pads to strip out.**

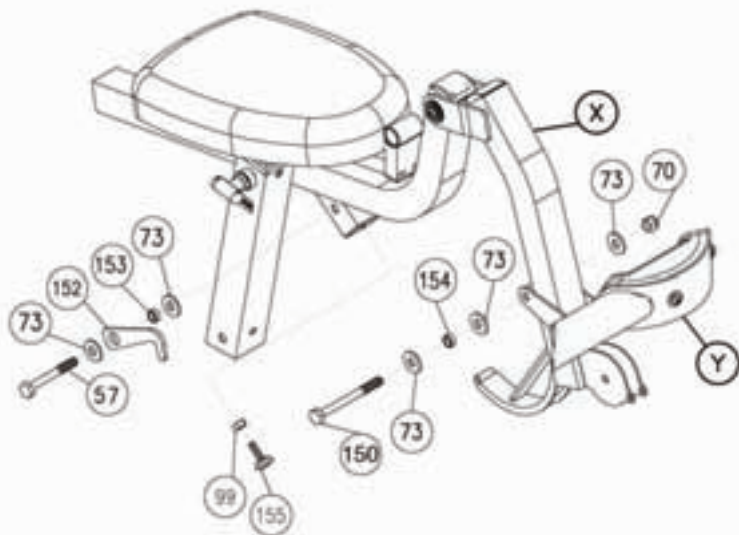
**Note:**

You should now **wrench tighten** all bolts and nuts in this step. Do NOT re-tighten any of the pad bolts.





**REVERSE SIDE DRAWING**



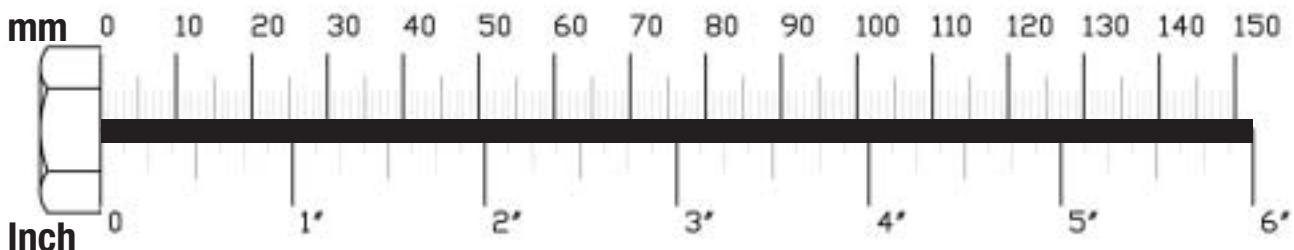
**STEP****7**

**Be careful to assemble all components in the sequence they are presented.**

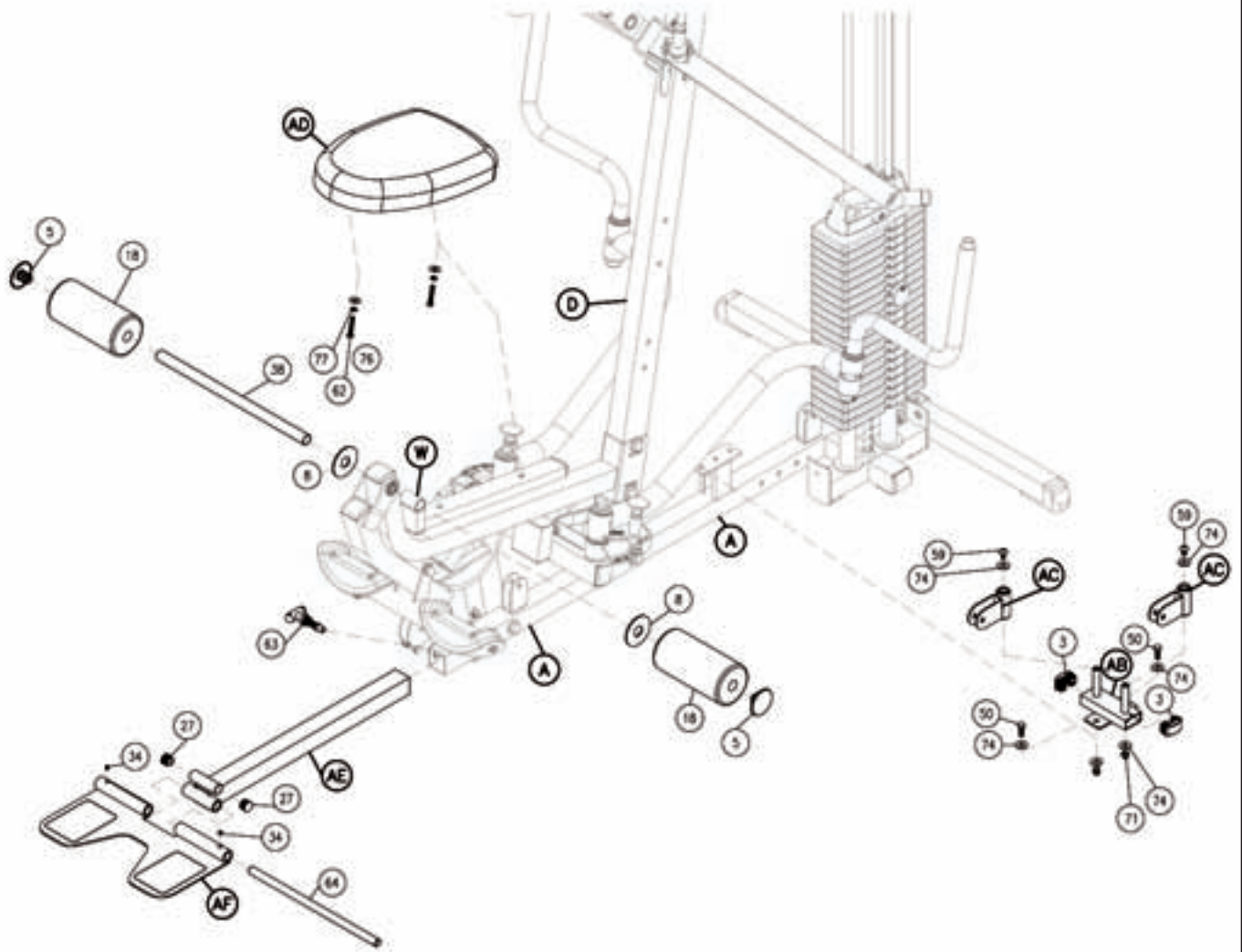
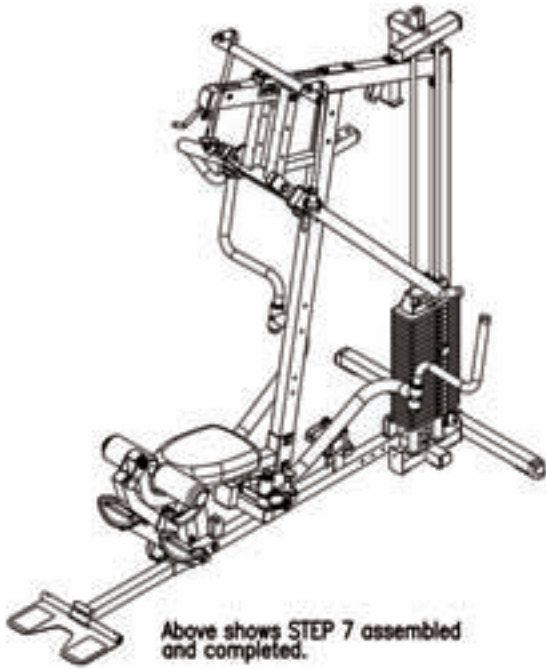
- A. Attach Pulley Platform (AB) to Main Base Frame (A) as shown using:  
**Two 50 (3/8" x 1" hex head bolt)**  
**Four 74 (3/8" washer)**  
**Two 71 (3/8" nylon lock nut)**
- B. Attach two Pulley Swivels (AC) to Pulley Platform (AB) as shown using:  
**Two 59 (3/8"x 5/8" round allen head bolt)**  
**Two 74 (3/8" washer)**  
Insert two Curved End Caps (3) into Pulley Platform (AB) as shown.
- C. Insert two Curved End Caps (3) into Seat Pad Frame (W) as shown.  
Attach Seat Pad (AD) to Seat Pad Frame (W) using:  
**Two 62 (5/16" x 1 3/4" hex head bolt)\***  
**Two 77 (5/16" spring lock washer)**  
**Two 76 (5/16" washer)**  
**\*Do NOT over-tighten these bolts. Tighten these bolts until spring lock washer is flat. Over - tightening these bolts will cause T - nuts in pads to strip out.**
- D. Slide 4"x 8" Foam Rollers (18) onto Foam Roller Bar (38) and attach to Seat Pad Frame (V). Hold Foam Rollers (18) in place with 3" Plastic Washer (8) on the inside and Plastic Roller End Cap (5) on the outside as shown.
- E. Slide Foot Brace Adjuster (AE) into Main Base Frame (A) and hold in place with Pop Pin (63).
- F. Attach Foot Brace (AF) to Foot Brace Adjuster (AE) with Shaft (64).  
Tighten Allen Screws (34).  
Insert Round End Caps (27) to Foot Brace Adjuster (AE), and attach Grip Tape (16) to Foot Brace (AF) as shown.

**Note:**

**You should now wrench tighten all bolts and nuts in this step. Do NOT re-tighten any of the pad bolts.**



STEP  
**7**

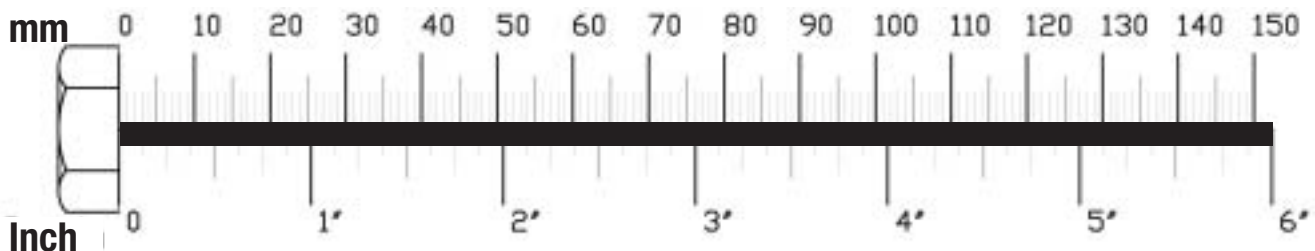


**STEP****8**

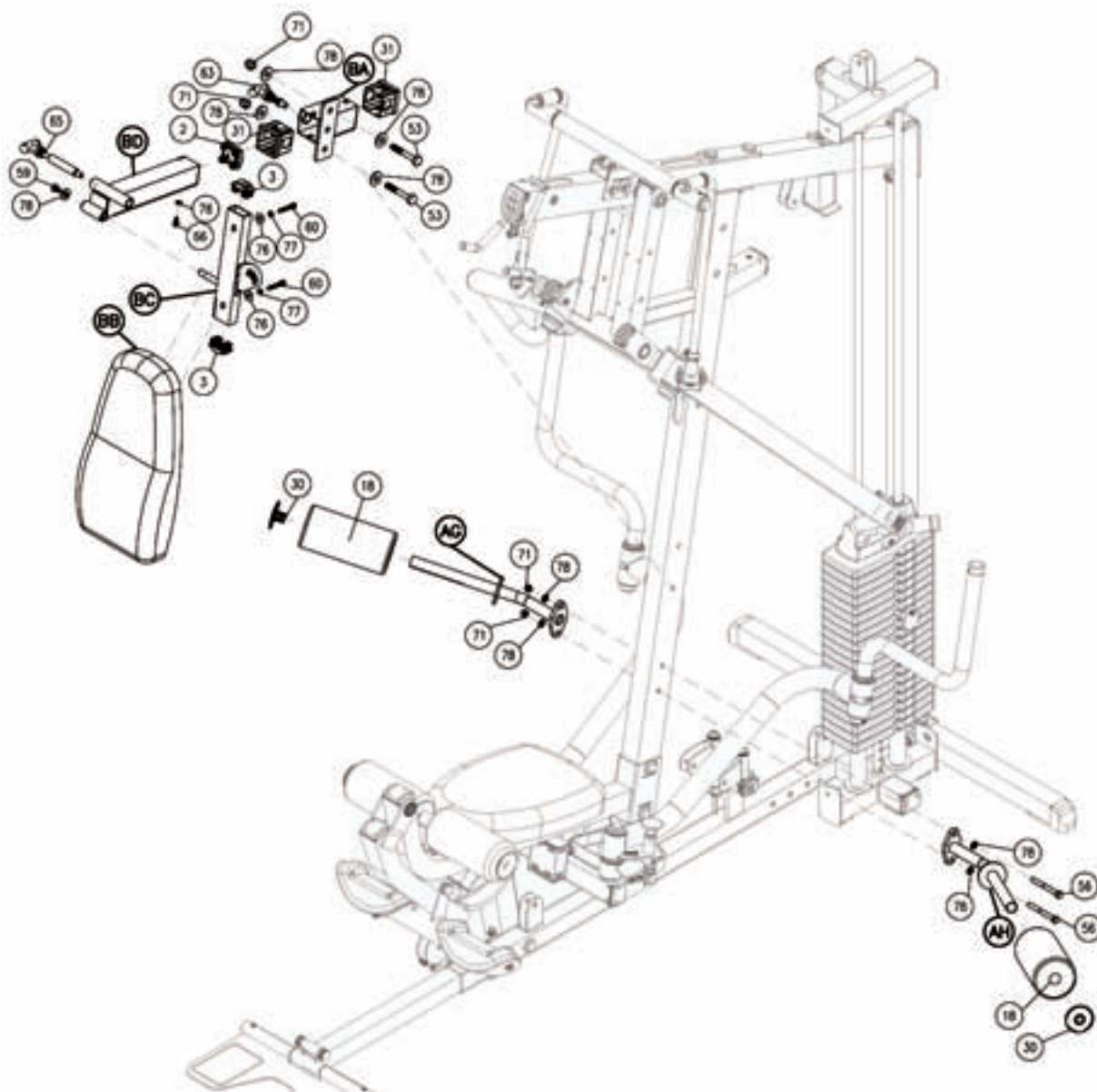
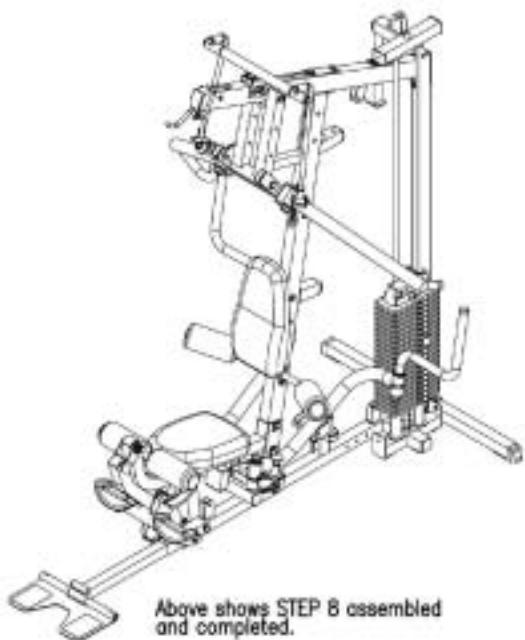
**Be careful to assemble all components in the sequence they are presented.**

- A. Attach Right Leg Hold Down (AG) and Left Leg Hold Down (AH) to the Angled Support Frame (D) using:  
**Two 56 (3/8" x 3 1/4" hex head bolt)**  
**Four 78 (3/8" washer)**  
**Two 71 (3/8" nylon lock nut)**  
Slide two 4"x 8" Foam Rollers (18) onto the two Leg Hold Downs (AG) and (AH). Hold in place with two Plastic Roller End Caps (30).
- B. Insert two Nylon Bushings (31) into Back Pad Holder (BA).  
Attach Back Pad Holder (BA) to Angled Support Frame (D) using:  
**Two 53 (3/8" x 3" hex head bolt)**  
**Four 78 (3/8" washer)**  
**Two 71 (3/8" nylon lock nut)**
- C. Slide two Convex End Caps (3) into the top and bottom of Back Pad Frame (BC).  
Attach Back Pad (BB) to Back Pad Frame (BC) using:  
**Two 60 (5/16" x 1 1/2" hex head bolt)\***  
**Two 77 (5/16" spring lock washer)**  
**Two 76 (5/16" washer)**  
**\*Do NOT over-tighten these bolts. Tighten these bolts until spring lock washer is flat. Over - tightening these bolts will cause T - nuts in pads to strip out.**
- D. Attach Back Pad Frame (BC) to Back Pad Adjuster (BD) with Pop Pin (65) and using:  
**One 59 (3/8" x 5/8" allen head bolt)**  
**One 78 (3/8" washer)**
- E. Slide Convex End Cap (2) into the Back Pad Adjuster (BD).  
Slide Back Pad Adjuster (BD) into Back Pad Holder (BA) and hold in place with Pop Pin (63) and using:  
**One 66 (5/16" x 1/2" flat allen head bolt)**  
**One 76 (5/16" washer)**

**NOTE:**  
**You should now make sure all bolts and nuts are wrench tight.**  
**Do NOT re-tighten any of the pad bolts.**  
**Also, leave all pulley bolts finger-tight until after STEP 15.**







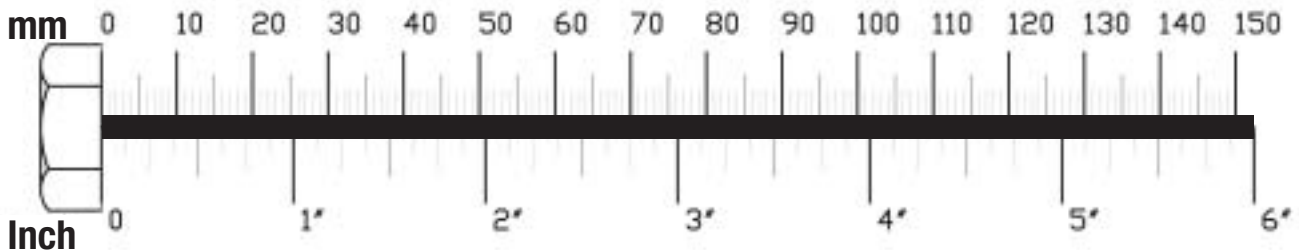
**STEP****9**

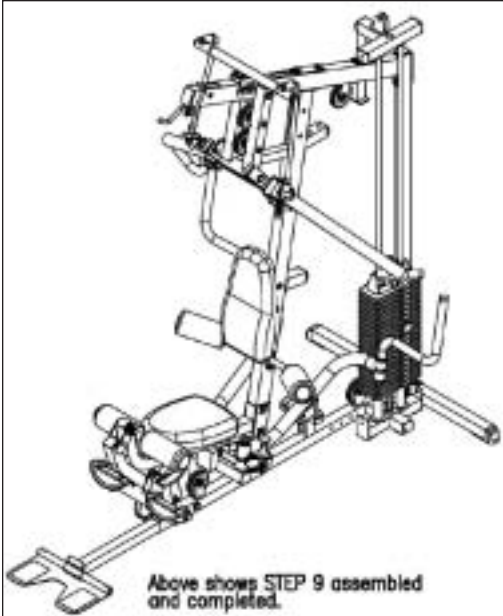
**Be careful to assemble all components in the sequence they are presented.**

**NOTE:**

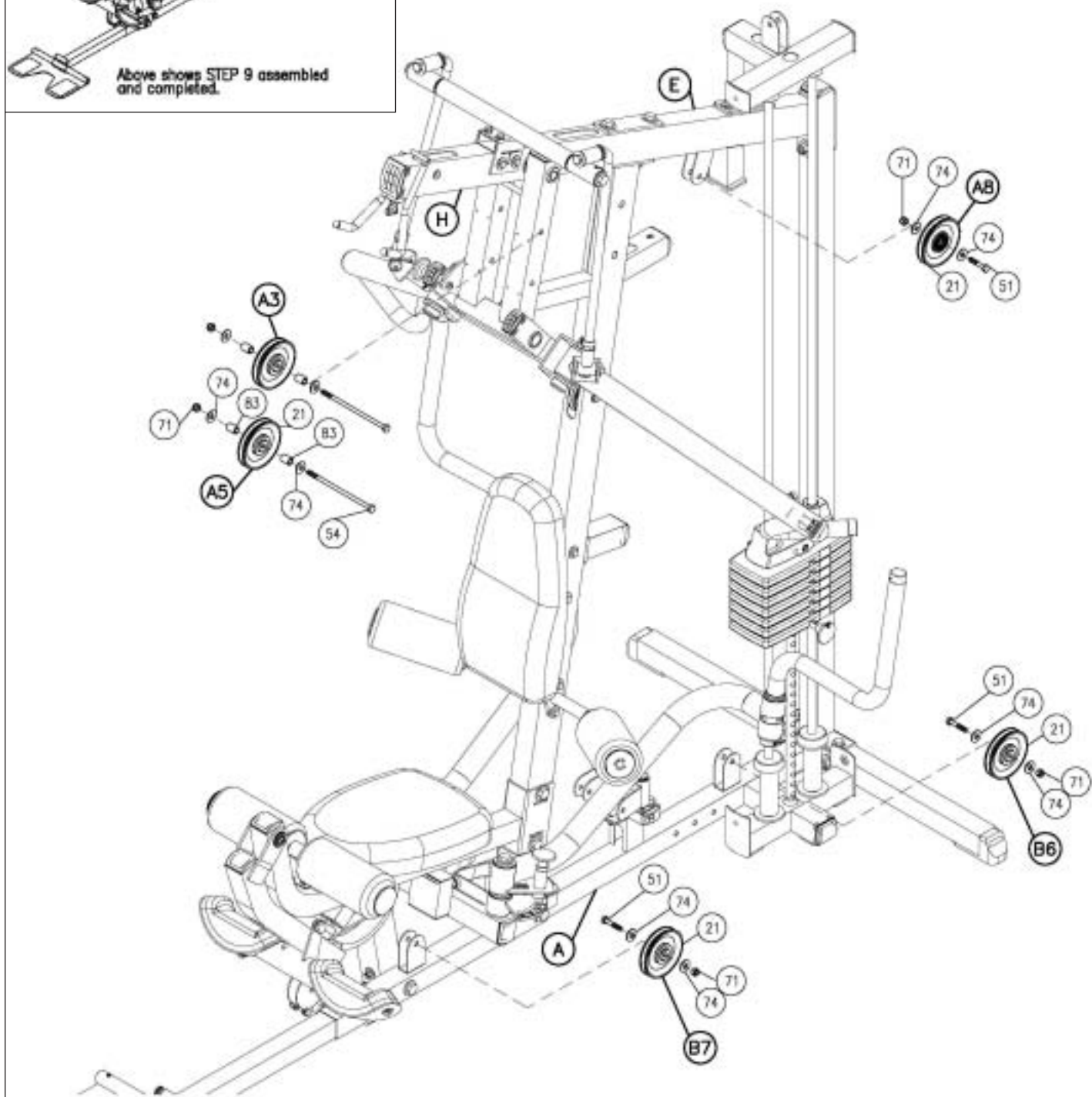
**Leave all pulley bolts hand tight until step 15 is completed.**

- A. Install Pulley (A3) and Pulley (A5) into Seated Press Arm Support (H) using for each pulley:  
**One 54 (3/8" x 7 1/4" hex head bolt)**  
**Two 74 (3/8" washer)**  
**Two 83 (steel bushing)**  
**One 71 (3/8" nylon lock nut)**
- B. Install Pulley (A8) into the pulley flange on Top Frame (E) as shown using:  
**One 51 (3/8" x 1 3/4" hex head bolt)**  
**Two 74 (3/8" washer)**  
**One 71 (3/8" nylon lock nut)**
- C. Install Pulley (B6) onto Main Base Frame (A) as shown using:  
**One 51 (3/8" x 1 3/4" hex head bolt)**  
**Two 74 (3/8" washer)**  
**One 71 (3/8" nylon lock nut)**
- D. Install Pulley (B7) onto Main Base Frame (A) as shown using:  
**One 51 (3/8" x 1 3/4" hex head bolt)**  
**Two 74 (3/8" washer)**  
**One 71 (3/8" nylon lock nut)**





Above shows STEP 9 assembled and completed.



Be careful to assemble all components in the sequence they are presented.

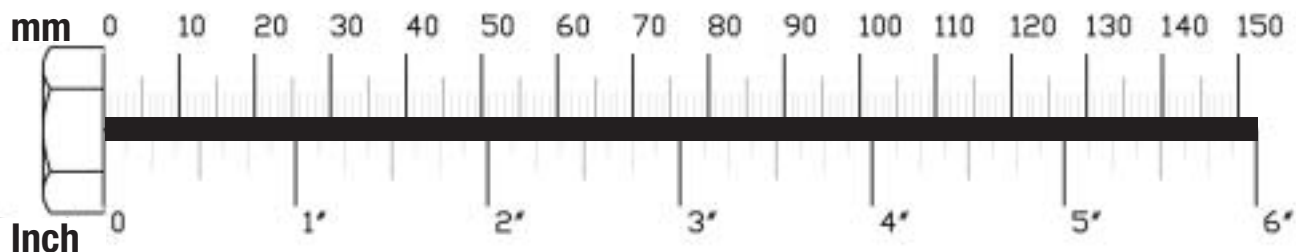
### High Pulley Cable (85)



**Note:**

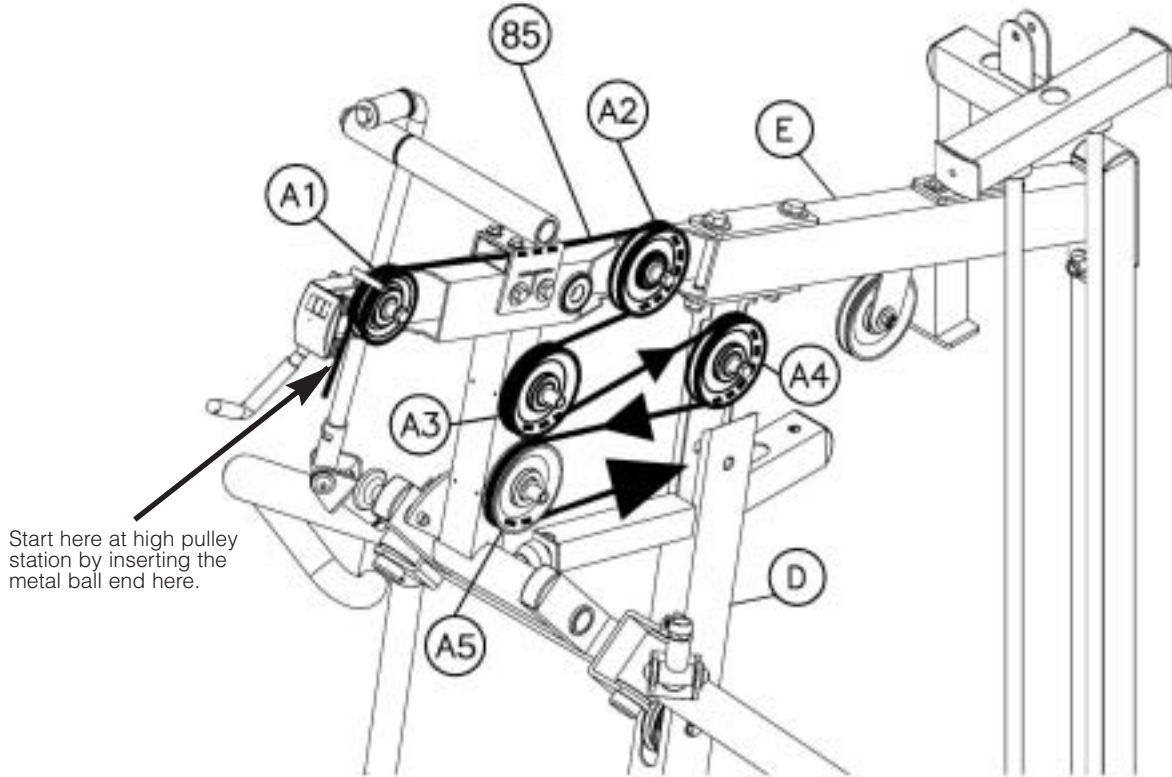
Leave all pulley bolts hand tight until step 15 is completed.

- A. Begin at the high pulley station. Route the metal ball end of the High Pulley Cable (85) up and through the opening where Pulley (A1) will be installed. Route the metal ball end under the Bi-Angular Bars (J) and then down through the next opening where Pulley (A2) will be installed.
- B. Install Pulley (A1) under Cable (85) and into Top Frame (E) as shown using:  
**One 52 (3/8" x 2 3/4" hex head bolt)**  
**Two 84 (nylon bushing)**  
**One 71 (3/8" nylon lock nut)**
- C. Install Pulley (A2) under Cable (85) and into Top Frame (E) as shown using:  
**One 52 (3/8" x 2 3/4" hex head bolt)**  
**Two 84 (nylon bushing)**  
**One 71 (3/8" nylon lock nut)**
- D. Route Cable (85) over the top and around pre-installed Pulley (A3) as shown. Route Cable (85) around Pulley (A4) and install Pulley (A4) into Angled Support Frame (D) using:  
**One 52 (3/8" x 2 3/4" hex head bolt)**  
**Two 84 (nylon bushing)**  
**One 71 (3/8" nylon lock nut)**
- E. Route Cable (85) between Pulley (A3) and pre-installed Pulley (A5). Route Cable (85) around Pulley (A5) and back through Angled Support Frame (D).

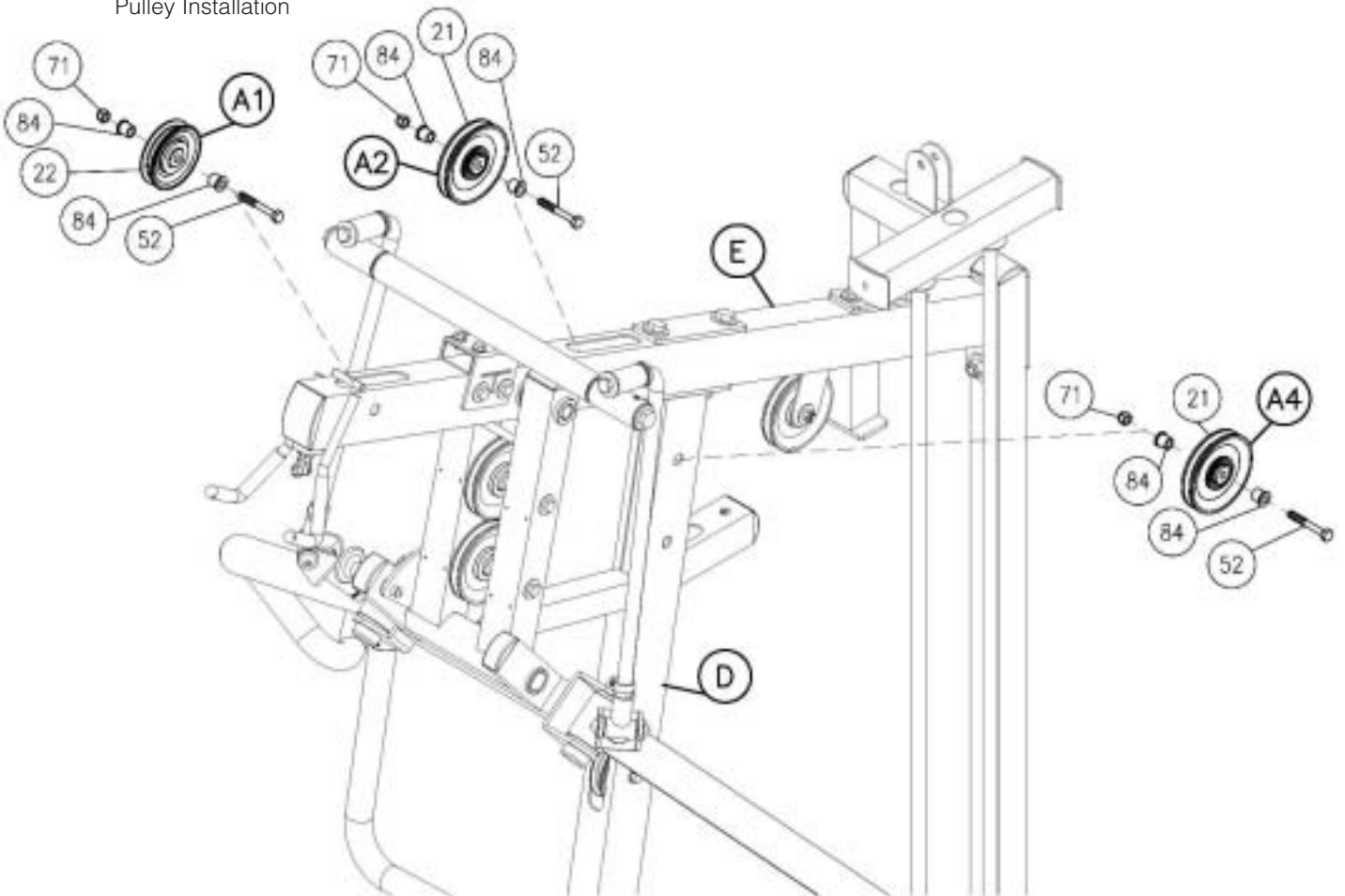


**Diagram 1**  
Cable Installation

Lat Pulldown  
Cable



**Diagram 2**  
Pulley Installation



**Be careful to assemble all components in the sequence they are presented.**

### **High Pulley Cable (85)**



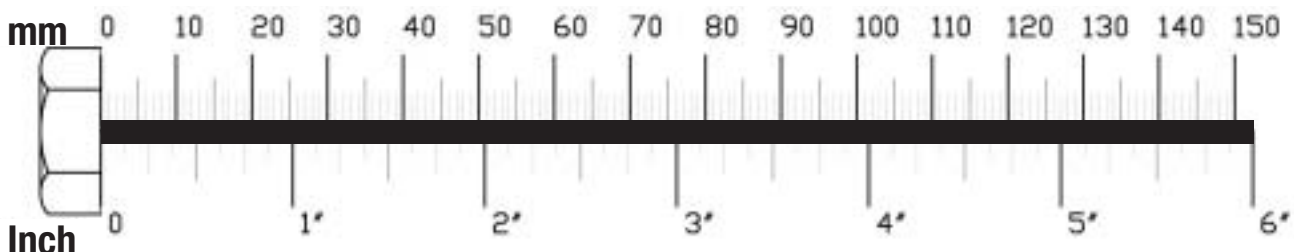
**Note:**

**Leave all pulley bolts hand tight until step 15 is completed.**

- A. Install Pulley (A6) under Cable (85) and into Angled Support Frame (D) using:
  - One 52 (3/8" x 2 3/4" hex head bolt)**
  - Two 84 (nylon bushing)**
  - One 71 (3/8" nylon lock nut)**
 Route Cable (85) down through the small arm sticking out of the Angled Support Frame (D).
  
- B. Route Cable (85) through the top of the Double Pulley Holder (CA). Install Pulley (A7) using:
  - One 51 (3/8" x 1 3/4" hex head bolt)**
  - Two 74 (3/8" washer)**
  - One 71 (3/8" nylon lock nut)**
  
- C. Route Cable (85) up to Top Frame (E), over pre-installed Pulley (A8), and down to 45 Degree Double Pulley Holder (CB).  
 Route Cable (85) through the top of the 45 Degree Double Pulley Holder (CB). Install Pulley (A9) using:
  - One 51 (3/8" x 1 3/4" hex head bolt)**
  - Two 74 (3/8" washer)**
  - One 71 (3/8" nylon lock nut)**
  
- C. Route Cable (85) up through the Top Weight Stack Frame (G). Install Pulley (A10) using:
  - One 51 (3/8" x 1 3/4" hex head bolt)**
  - Two 74 (3/8" washer)**
  - One 71 (3/8" nylon lock nut)**
 Route Cable (85) up over Pulley (A10) and down through Top Weight Stack Frame (G) and toward weight stack.
  
- D. The Metal Ball End of Cable (85) should be hanging just above the weight stack. Remove Allen Bolt (102) from Selector Rod Top Bolt (103), slide Metal Ball End of Cable (85) through Selector Rod Top Bolt (103). Attach Cable End Shaft (100) and securely tighten Allen Bolt (101). Pull Cable (85) tight, so Cable End Shaft (100) fits securely inside Selector Rod Top Bolt (103). Reinstall Allen Bolt (102) in Selector Rod Top Bolt (103) and tighten Nylon Lock Nut (71) to hold in place.

**NOTE:**

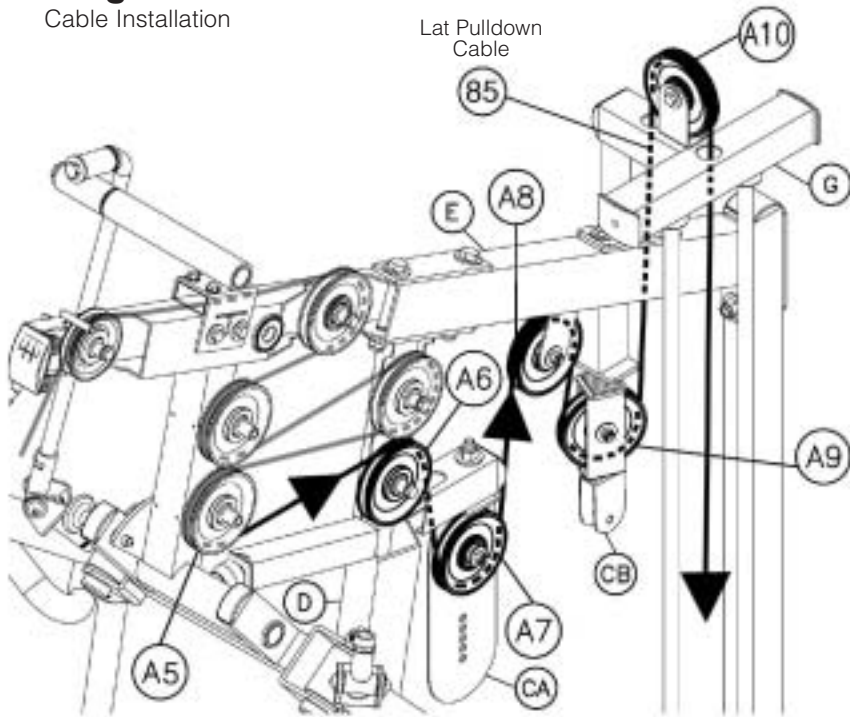
**Make sure the Selector Rod Top Bolt (103) is threaded inside Selector Rod (19) at least one half inch. Make sure Spring Lock Washer (105) is in place and wrench tighten Jam Nut (104).**



**Diagram 1**

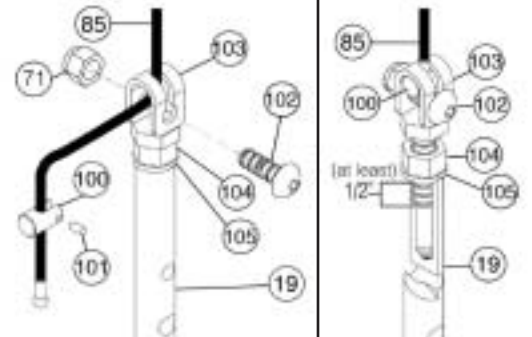
Cable Installation

Lat Pulldown  
Cable



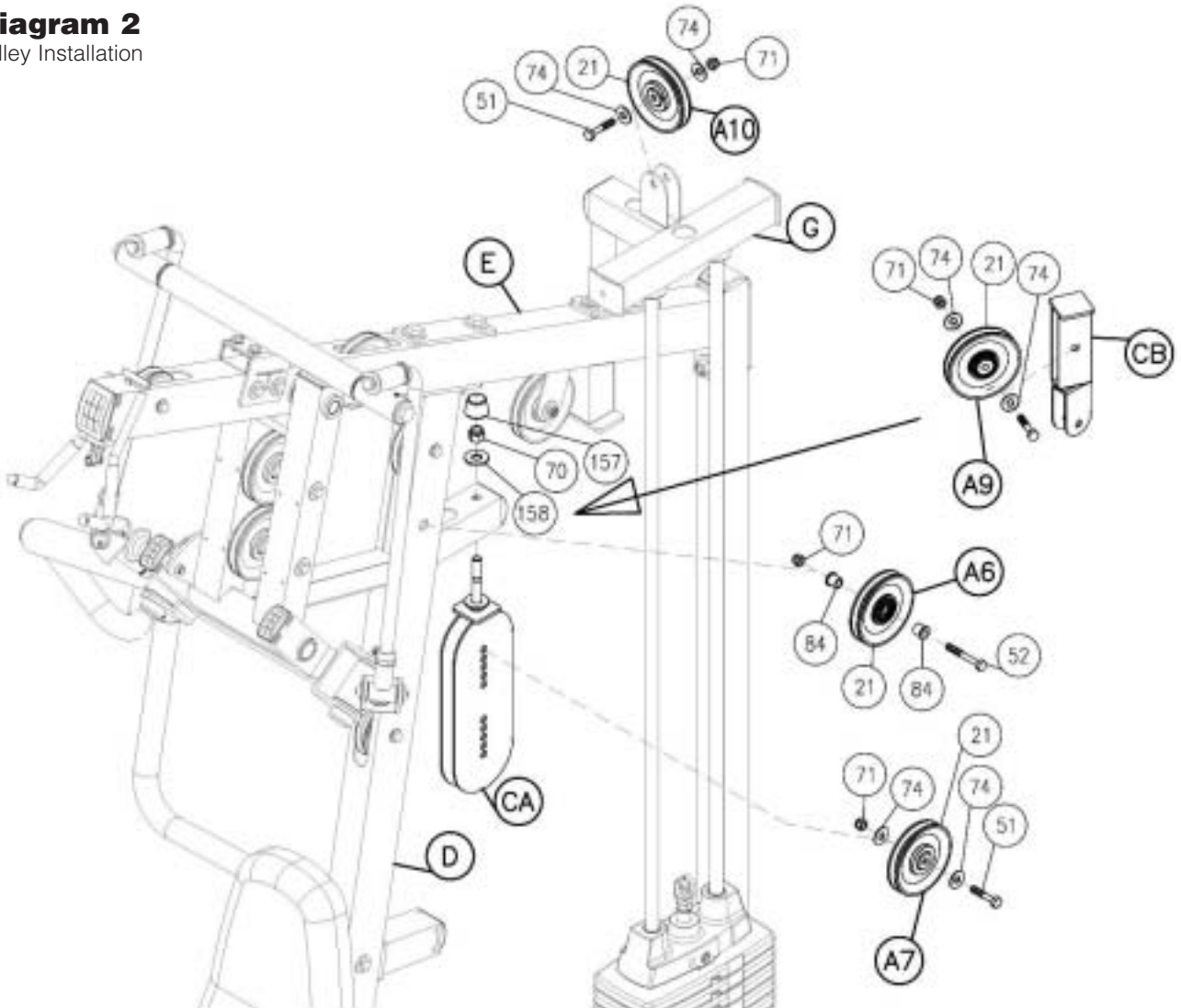
**⚠ WARNING ⚠**

Selector Rod Top Bolt (103) must be threaded a minimum of 1/2" into the Selector Rod (19), and Jam Nut (104) tightened securely against spring lock washer (105) to ensure proper connection. Check the Jam Nut (104) once a week to make sure it is tight.



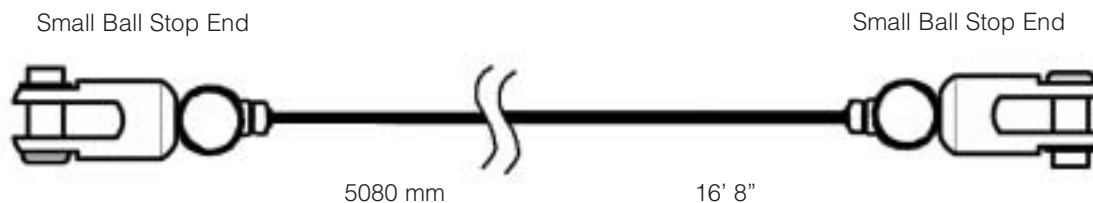
**Diagram 2**

Pulley Installation



**Be careful to assemble all components in the sequence they are presented.**

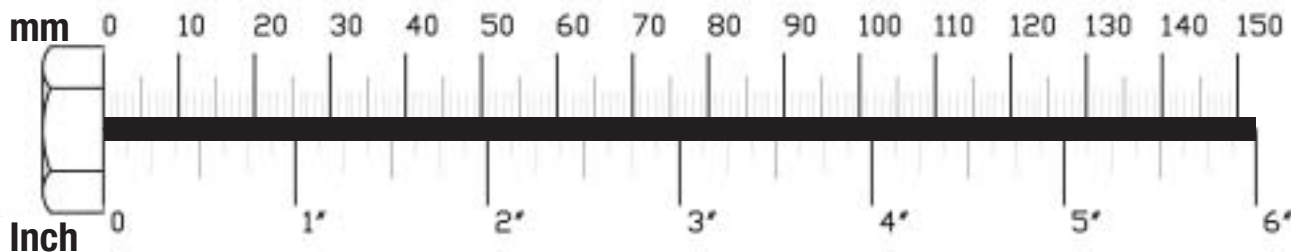
### **Low Pulley Cable (86)**



**Note:**

**Leave all pulley bolts hand tight until step 15 is completed.**

- A. Insert either end of Low Pulley Cable (86) into the opening in Angled Support Frame (D), above Back Pad (BB), and pull entire length of Cable (86) through.
- B. Install Pulley (B1), under Cable (86) and into Angled Support Frame (D) as shown using:  
**One 57 (3/8" x 2 1/2" hex head bolt)**  
**Two 84 (nylon bushing)**  
**One 71 (3/8" nylon lock nut)**
- C. Route Cable (86) through the top of the 90 Degree Pulley Holder (CC) and hold in place by installing Pulley (B2) using:  
**One 51 (3/8" x 1 3/4" hex head bolt)**  
**Two 74 (3/8" washer)**  
**One 71 (3/8" nylon lock nut)**
- D. Route Cable (86) up and through the bottom of Double Pulley Holder (CA). Install Pulley (B3) using:  
**One 51 (3/8" x 1 3/4" hex head bolt)**  
**Two 74 (3/8" washer)**  
**One 71 (3/8" nylon lock nut)**
- E. Route Cable (86) down and through the Single Pulley Holder (CD). Install Pulley (B4) using:  
**One 51 (3/8" x 1 3/4" hex head bolt)**  
**Two 74 (3/8" washer)**  
**One 71 (3/8" nylon lock nut)**



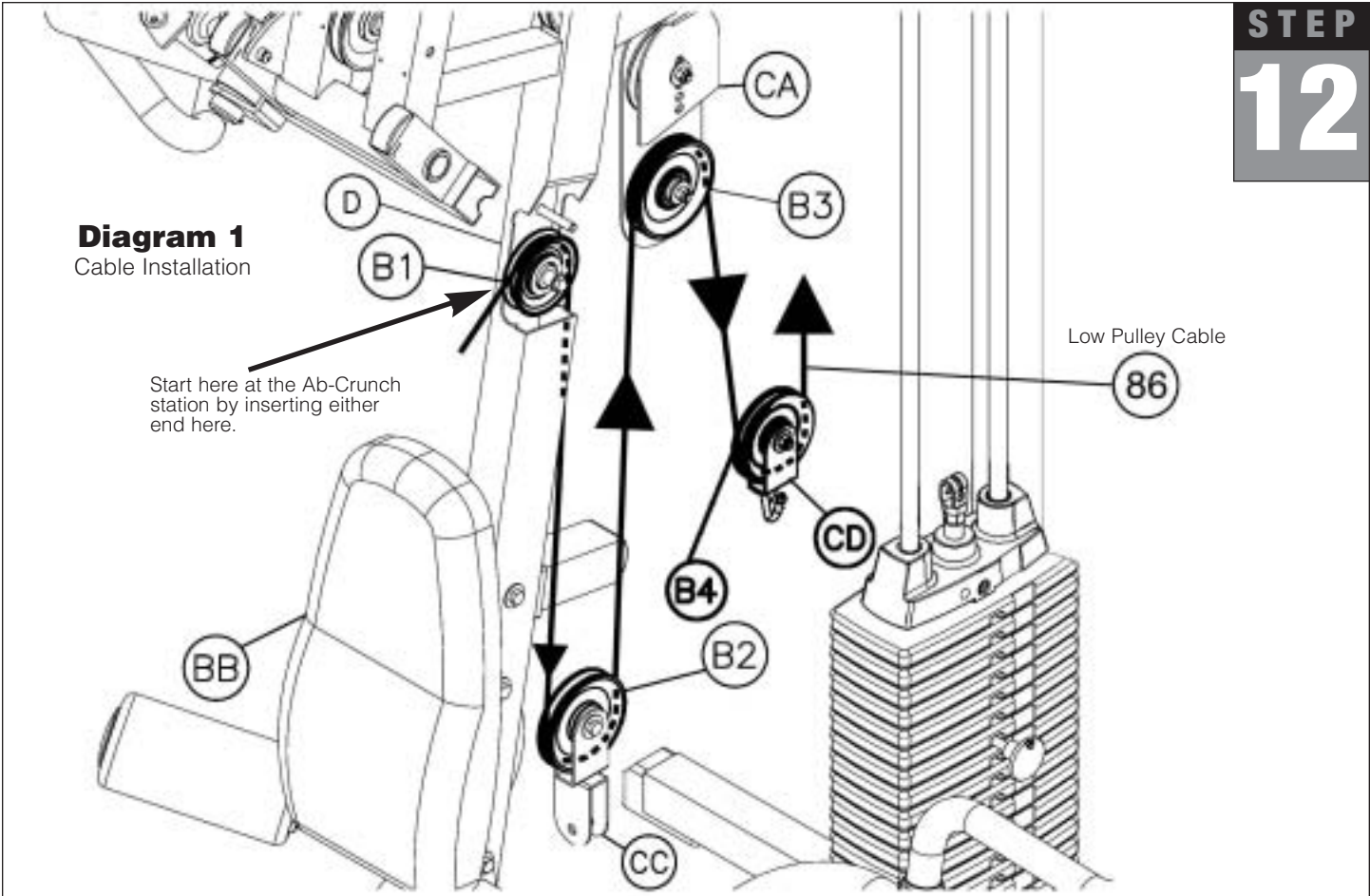


**Diagram 1**  
Cable Installation

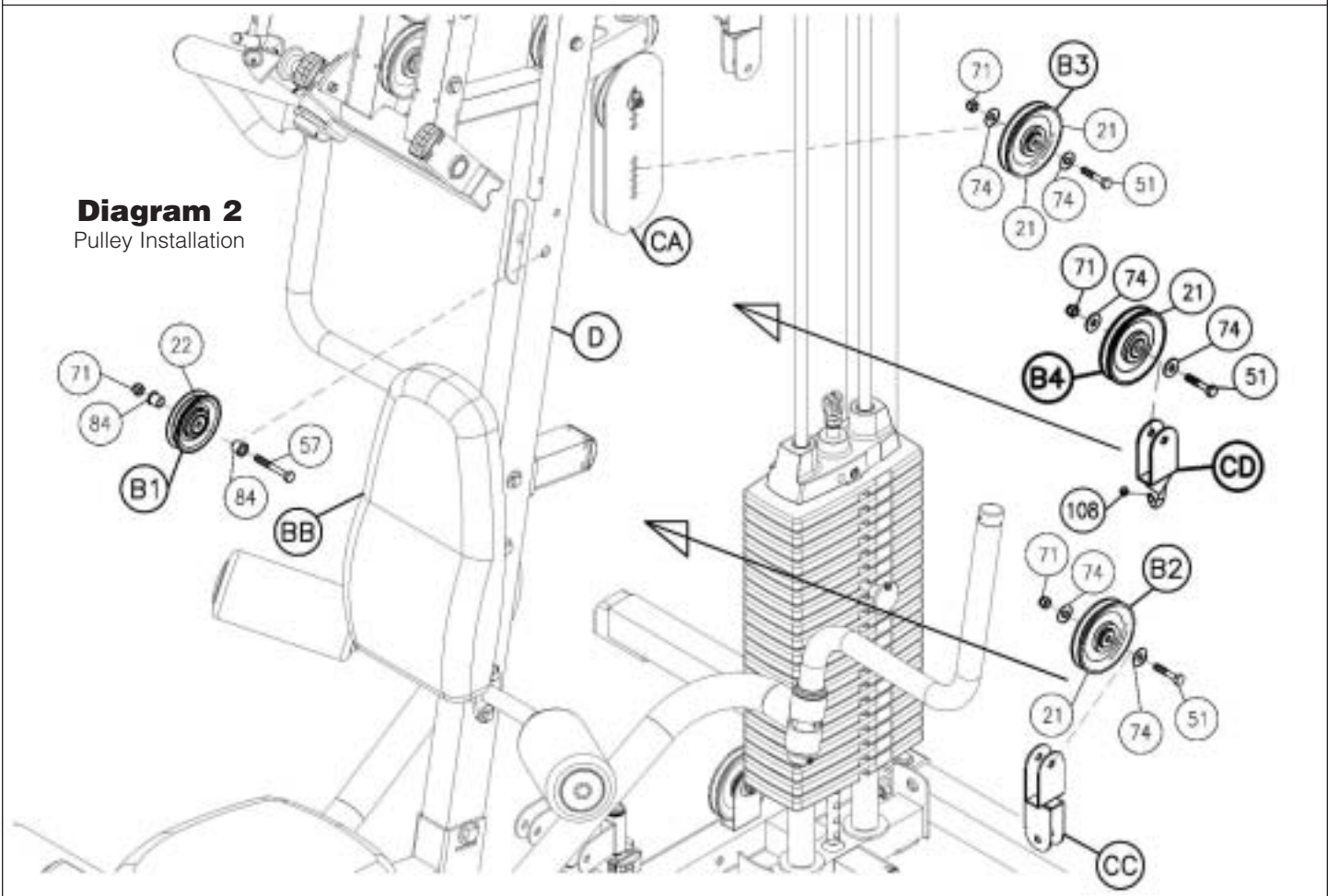
Start here at the Ab-Crunch station by inserting either end here.

Low Pulley Cable

86

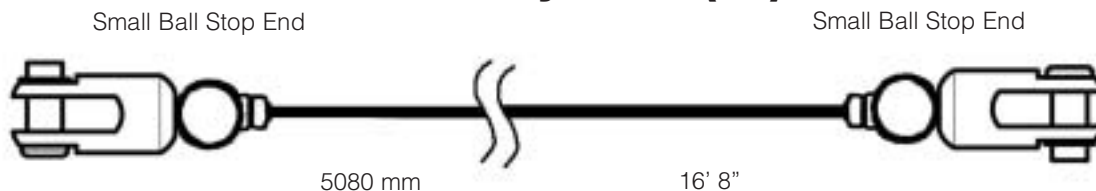


**Diagram 2**  
Pulley Installation



**Be careful to assemble all components in the sequence they are presented.**

### **Low Pulley Cable (86)**



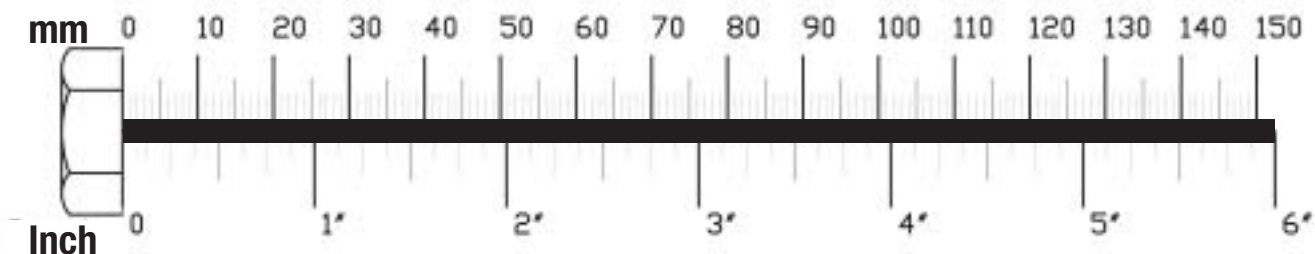
### **Short Cable (87)**



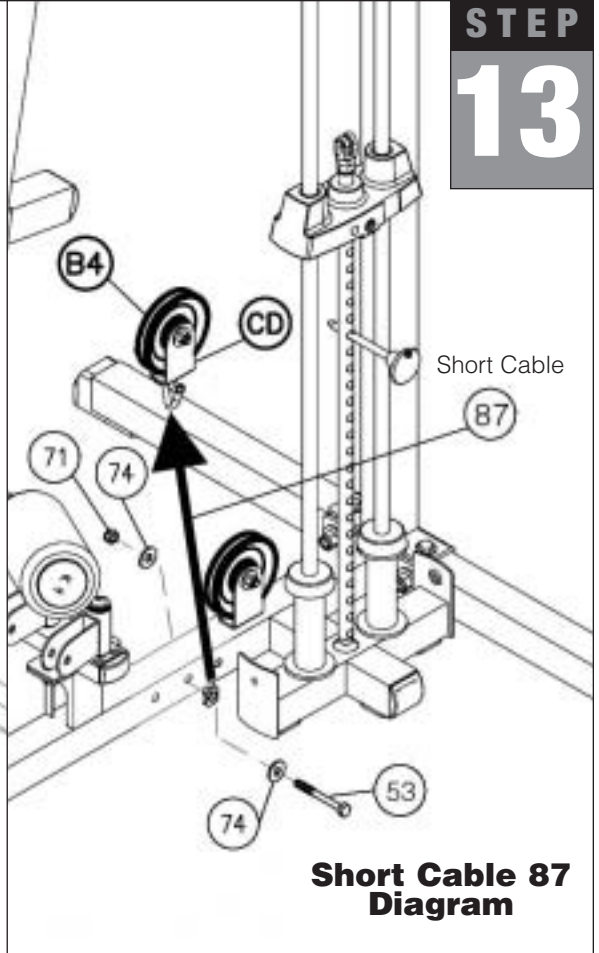
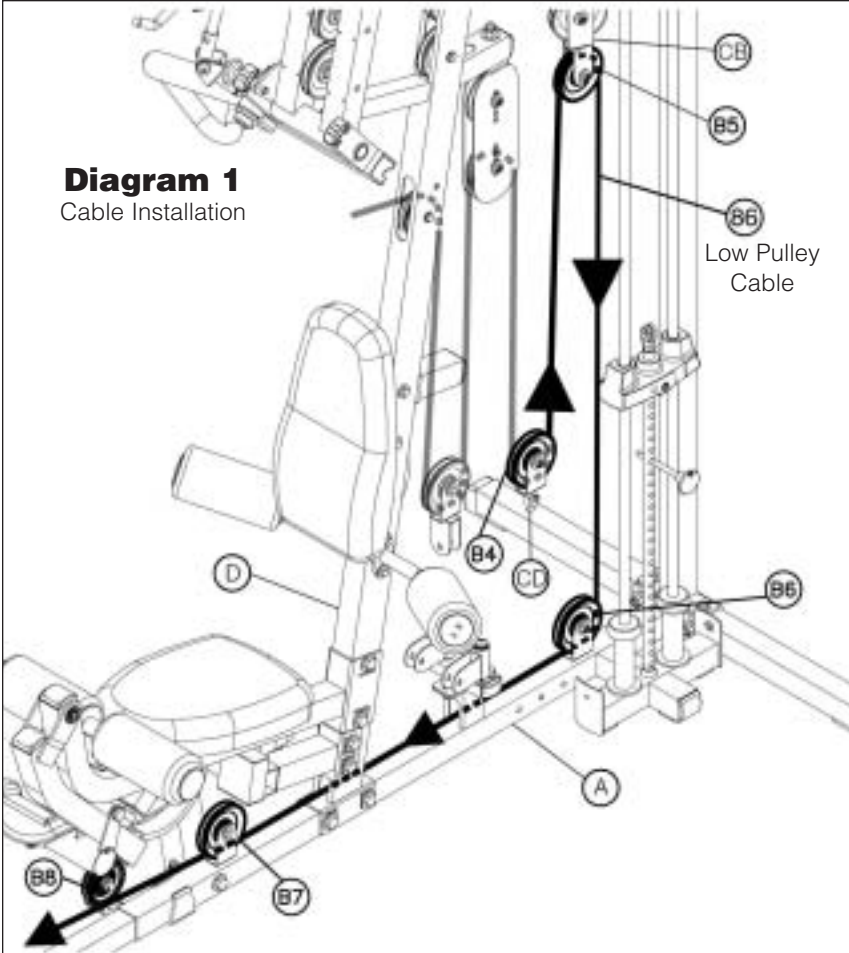
**NOTE:**

**Leave all pulley bolts hand tight until step 15**

- A. Route Cable (86) up and through the bottom of 45 Degree Double Pulley Holder (CB). Install Pulley (B5) using:  
**One 51 (3/8" x 1 3/4" hex head bolt)**  
**Two 74 (3/8" washer)**  
**One 71 (3/8" nylon lock nut)**
- B. Route Cable (86) down, around pre-installed Pulley (B6). Remove and re-install pulley as needed. Route Cable (86) forward and through the opening in Angled Support Frame (D). Route Cable (86) under pre-installed Pulley (B7). Remove and re-install pulley as needed. Insert Cable (86) through Leg Extension Arm (X) and install Pulley (B8) using:  
**One 51 (3/8" x 1 3/4" hex head bolt)**  
**Two 74 (3/8" washer)**  
**One 71 (3/8" nylon lock nut)**
- E. Attach Short Cable (87) to Main Base Frame (A) as shown using:  
**One 53 (3/8" x 3" hex head bolt)**  
**Two 74 (3/8" washer)**  
**One 71 (3/8" nylon lock nut)**
- F. Attach the other end of Cable (87) to the hook on the bottom of Pulley Holder (CD) as shown.

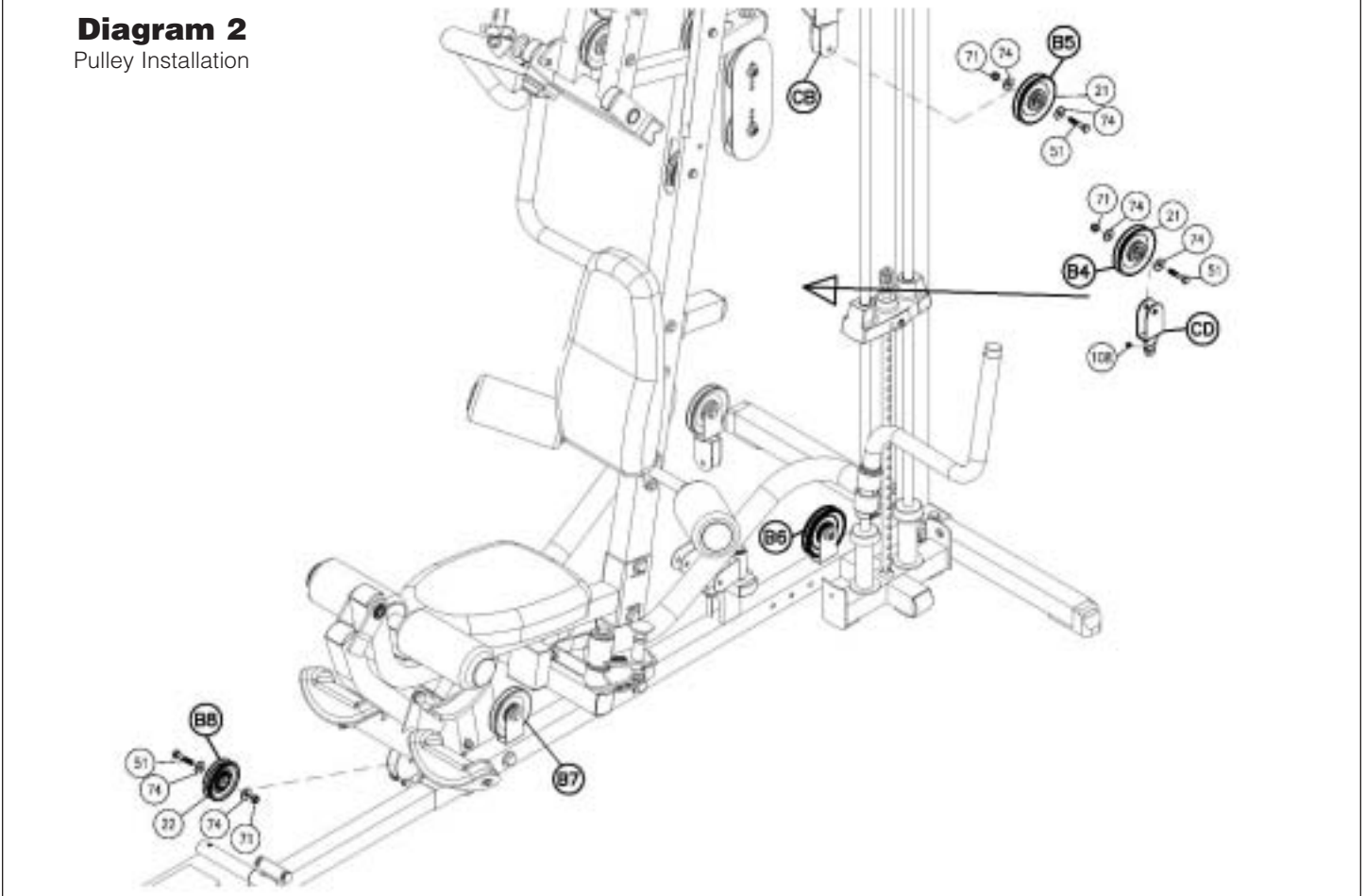


**Diagram 1**  
Cable Installation



**Short Cable 87**  
**Diagram**

**Diagram 2**  
Pulley Installation



**Be careful to assemble all components in the sequence they are presented.**

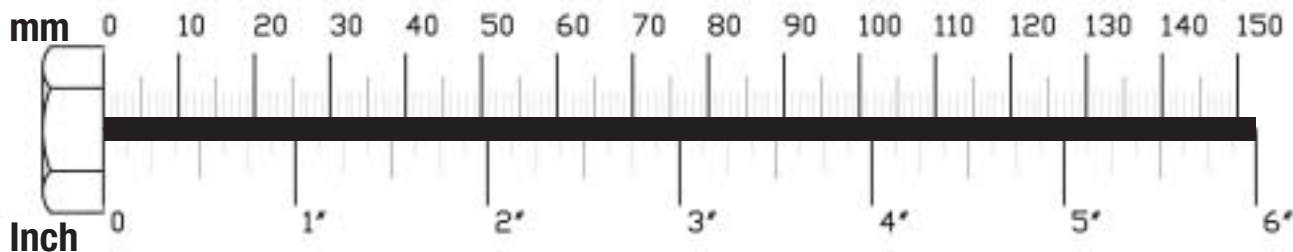
### **Pec Dec Cable (88)**



**NOTE:**

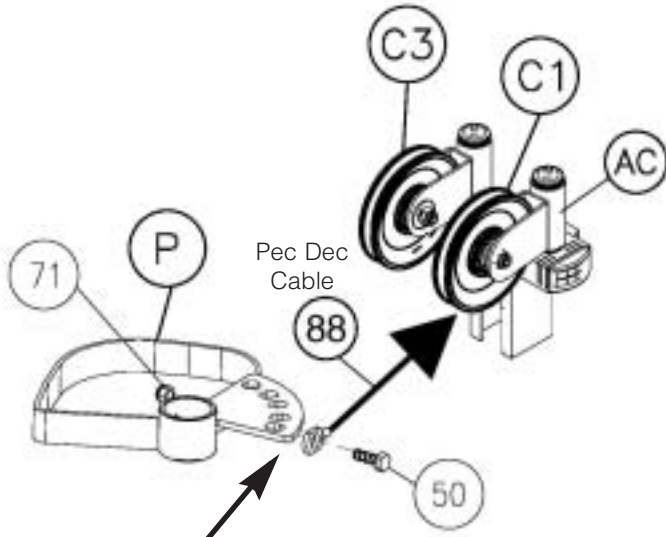
**Leave all pulley bolts hand tight until step 15**

- A. Bolt Pec Dec Cable (88) to Left Pec Dec Cam (P) as shown in diagram 1 using:  
**One 50 (3/8" x 1" hex head bolt)**  
**One 71 (3/8" nylon lock nut)**
- B. See diagram 1. Route Cable (88) through Pulley Swivel (AC) on the left side, hold cable in place with Pulley (C1) using:  
**One 51 (3/8" x 1 3/4" hex head bolt)**  
**Two 74 (3/8" washer)**  
**One 71 (3/8" nylon lock nut)**
- C. See diagram 1. Route Cable (88) up and into 90 Degree Double Pulley Holder (CC) and install Pulley (C2) using:  
**One 51 (3/8" x 1 3/4" hex head bolt)**  
**Two 74 (3/8" washer)**  
**One 71 (3/8" nylon lock nut)**
- B. Insert Cable (88) through Pulley Swivel (AC) on the right side, hold cable in place by installing Pulley (C3) as shown in diagram 2 using:  
**One 51 (3/8" x 1 3/4" hex head bolt)**  
**Two 74 (3/8" washer)**  
**One 71 (3/8" nylon lock nut)**
- C. Attach Cable (88) to Right Pec Dec Cam (S) as shown in diagram 1 using:  
**One 50 (3/8" x 1" hex head bolt)**  
**One 71 (3/8" nylon lock nut)**



**Diagram 1**

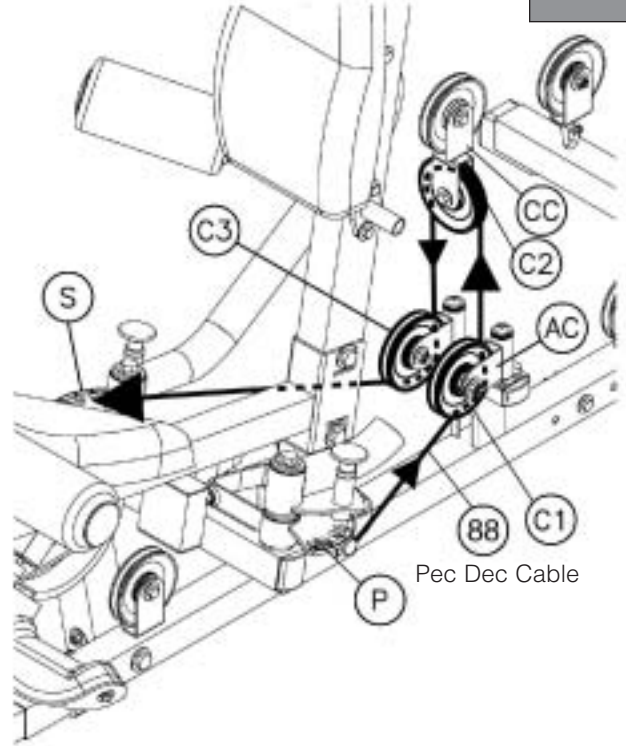
Cable Installation



Start routing cable here by bolting cable to Left Pec Dec Cam (P).

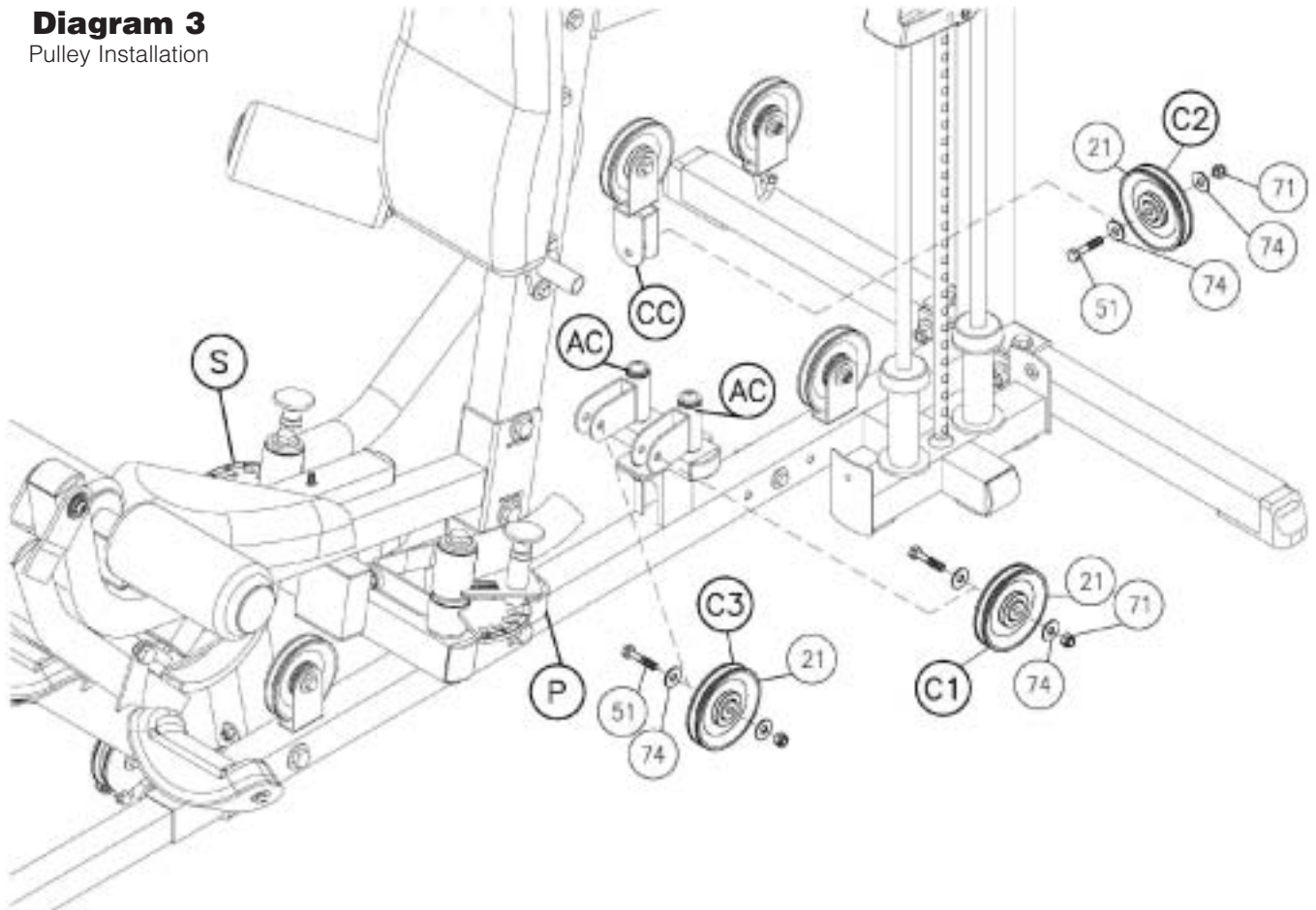
**Diagram 2**

Cable Installation



**Diagram 3**

Pulley Installation



**Be careful to assemble all components in the sequence they are presented.**

**NOW IS THE TIME TO MAKE ALL NECESSARY  
CABLE ADJUSTMENTS**

After cable installation is complete you must check all cables for proper tension. Obvious signs that cable tension problems exist include:

- Top Plate (17) does not rest directly on the top Weight Stack Plate (38).
- The holes in the Selector Bar (19) do not line up with holes in the Weight Stack Plates (38).
- Cable(s) are sloppy and there is no resistance from the weight stack for the first few inches of the exercise.

There are FIVE areas for cable adjustment on the G6B:

- A. Selector Rod Top Bolt (103).\*
- B. TWO adjustments in Double Pulley Holder (CA).
- C. TWO Rubber Stops (98) and (155).

**\*SEE NOTE 1 ON PAGE 39**

If there is too much tension, and the Top Plate (17) is not resting directly on the top weight stack plate:

- 1st. -Move pulley (A7) up, or Pulley (B3) down in the Double Pulley Holder (CA).
- 2nd. Turn and tighten one of the Rubber Stops (98) and (155).

If there is too much play or excessive slack:

- 1st. -Turn and loosen the Rubber Stops (98) and (155).
- 2nd. Move Pulley (A7) down, or Pulley (B3) up in the Double Pulley Holder (CA).
- 3rd. -Screw the Selector Rod Top Bolt (103) farther into the Selector Rod (19).

**NOTE:**

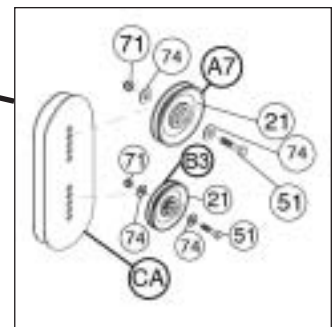
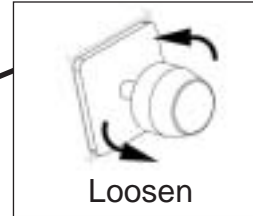
**Cables should be inspected daily and adjusted periodically to ensure safe and smooth operation.**

**NOTE:**

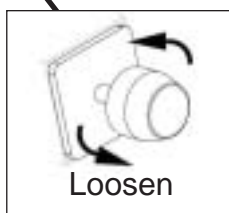
**After cable adjustment is complete, go back and tighten all pulley bolts.**

# STEP 15

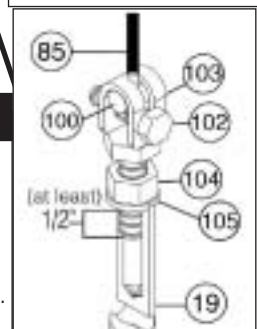
Turn and loosen Rubber Stop (98) to take up space and tighten cable.



Turn and loosen Rubber Stop (105) to take up space and tighten cable.



**NOTE 1**  
Check Jam Nut (104) weekly to be sure it is tight and locked onto the Selector Rod (19).



**⚠ WARNING ⚠**  
Selector Rod Top Bolt (103) **must** be threaded a minimum of 1/2" into the Selector Rod (19), and Jam Nut (104) tightened securely against spring lock washer (105) to ensure proper connection.

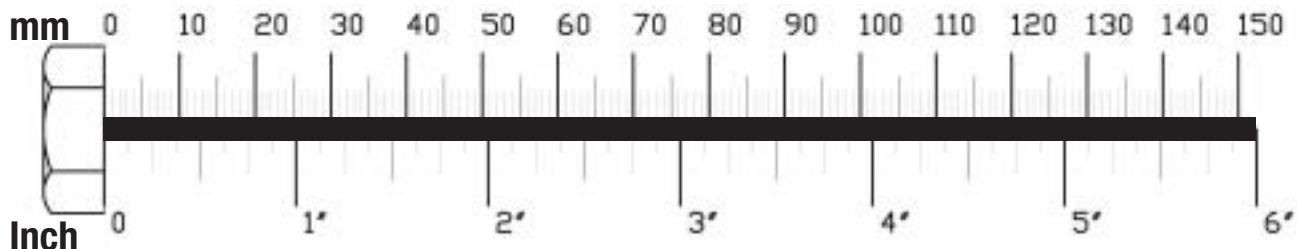
**Be careful to assemble all components in the sequence they are presented.**

**SEE NOTE 1 ON PAGE 41:**

- A. Apply weight stack numbers to weight stack Top Plate (17) and each Weight Stack Plate (38) as shown.

**SEE NOTE 2 ON PAGE 41:**

- B. Weight Stack Shroud (DA) is pre-assembled with Shroud Insert (DB). Attach Weight Stack Shroud (DA) to the side of the weight stack as shown. Bolt onto Main Base Frame (A) at the bottom and Top Weight Stack Frame (G) using:  
**Two 89 (3/8" x 5/8" round allen head)**  
**Two 74 (3/8" washer)**
- C. Attach Back Weight Stack Shroud (DC), to the back side of the weight stack, onto the Main Base Frame (A) at the bottom and to the Top Weight Stack Frame (G) as shown using:  
**Two 89 (3/8" x 5/8" round allen head)**  
**Two 74 (3/8" washer)**
- D. Attach Press Arm Shroud (DD) to the Seated Press Arm Support (H) using:  
**Four 90 (1/8" x 3/8" round allen head)**
- E. Connect the Water Bottle Bracket (91) to the Weight Stack Shroud (DA) using:  
**Two 92 (1/8" x 3/8" screw)**
- F. Slide the Water Bottle Holder (93) onto the Water Bottle Bracket (91) as shown.

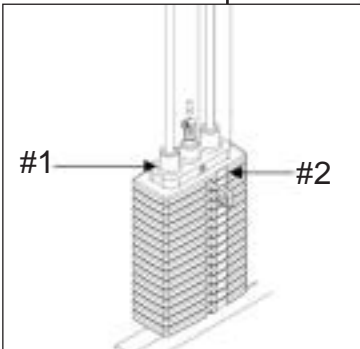
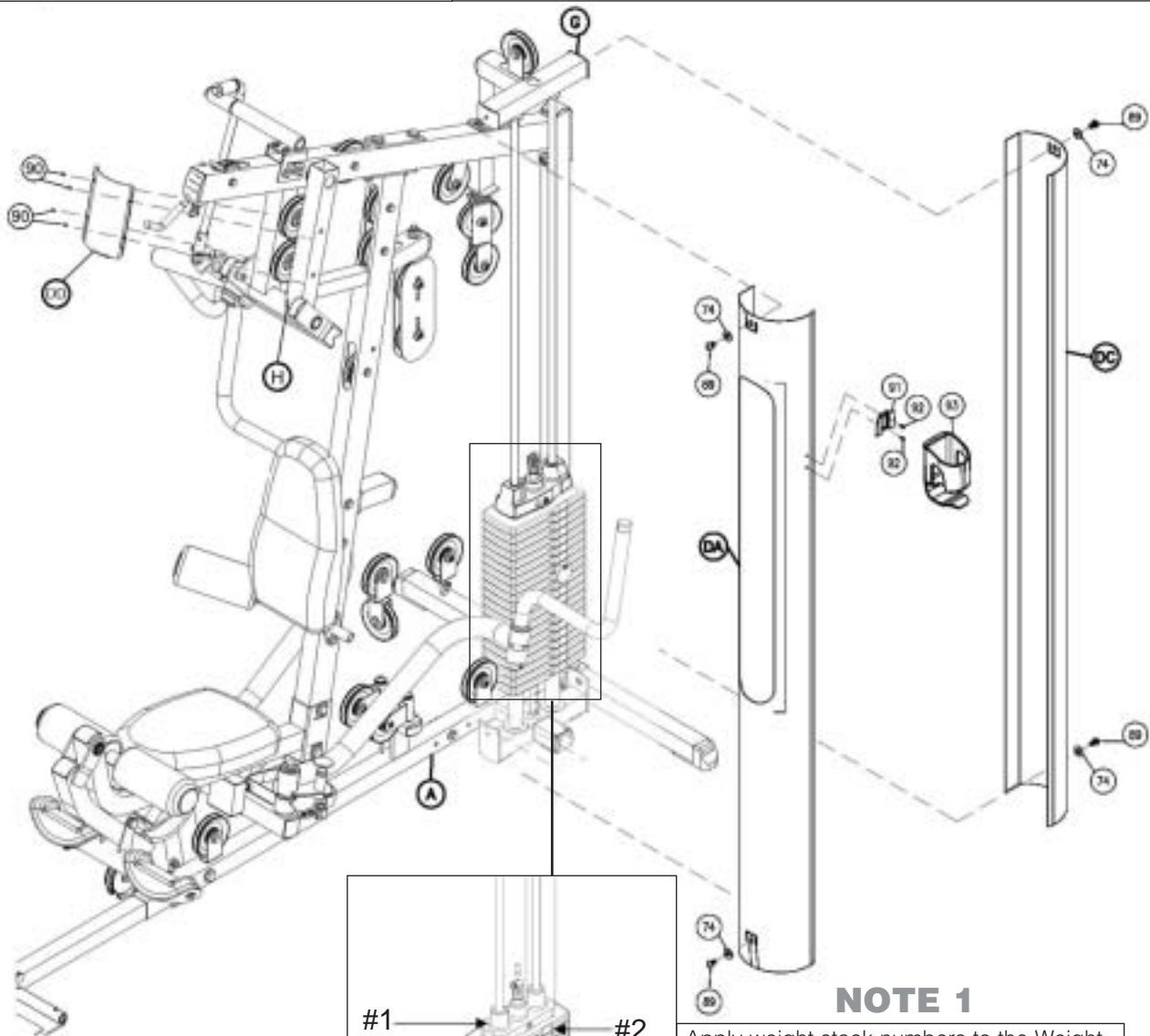
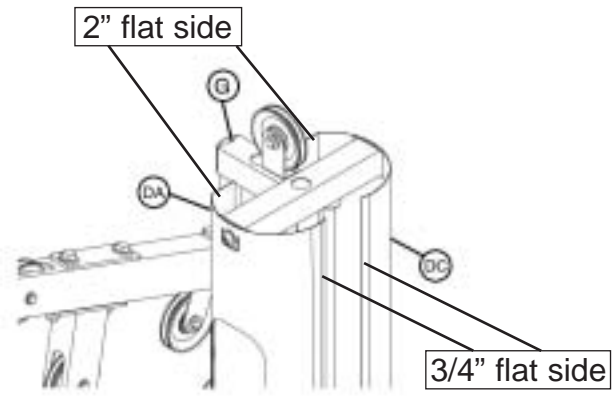
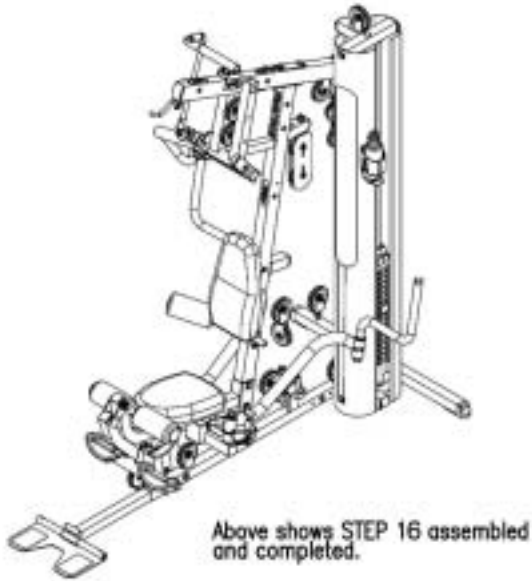




**STEP**  
**16**

**NOTE 2**

This is the top view of the two Weight Stack Shrouds. Note the shape of each shroud for proper placement.



**NOTE 1**

Apply weight stack numbers to the Weight Stack Plates (38). Start at the Top Plate (17) with the number 1, and the first plate should be number 2. The following Weight Stack Plates (38) should be numbered in sequential order down through the stack.

# A d j u s t m e n t s

Congratulations! You are done. After assembly, you should check all functions to ensure correct operation. If you experience problems, first recheck the assembly instructions to locate any possible errors made during assembly. If you are unable to correct the problem, call the dealer from whom you purchased the machine or call 1-800-833-1227 for the dealer nearest you.

Note: If any bolts seem to loosen periodically, use Loctite 242 for a long-term cure.

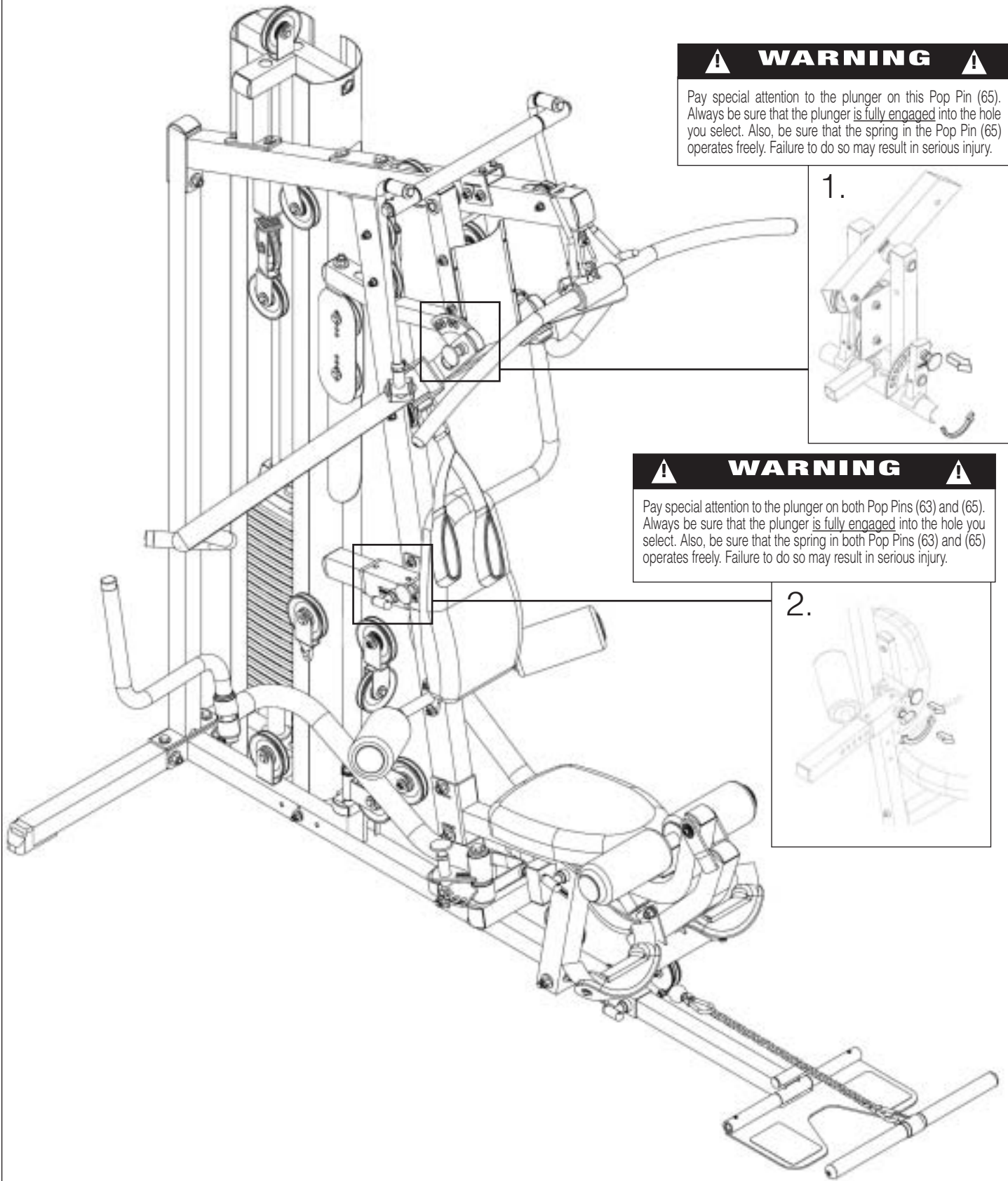
This gym is capable of a variety of different exercises, as well as, smooth and user-friendly adjustment features. The following pages of adjustments will help you to familiarize yourself with your new gym. We hope you are completely satisfied with this product and wish you many years of enjoyment.

## 1. SEATED PRESS ARMS ADJUSTMENT

- A. Grasp the Right Press Arm (M) with one hand.
- B. Pull the Flat Head Pop Pin (94) with your other hand to release the Press Arm Holder (K).
- C. Adjust the Press Arm Holder (K) to the desired position (depending on the exercise you are performing).
- D. Release the Flat Head Pop Pin, and make sure it is fully engaged into the selector hole.

## 2. BACK PAD (BB) ADJUSTMENT

- A. Grasp Back Pad (BB).
- B. Turn the T-Shaped Pop Pin (63) in Back Pad Holder (BA) counter clockwise to unlock it, and then pull the Pop Pin to release the Back Pad Adjuster (BD). Adjust the Back Pad to the desired position.
- C. Release the T-Shaped Pop Pin (63) and make sure it is fully engaged into the selector hole in the Back Pad Adjuster (BD). Turn T-Shaped Pop Pin clockwise to lock it in place.
- D. For certain exercises you may wish to change the angle of the Back Pad. Pull the T-Shaped Pop Pin (65) on the Back Pad Adjuster (BD), this will allow you to change to the desired angle.
- E. Release the T-Shaped Pop Pin (65) and make sure it is fully engaged into the selector hole.



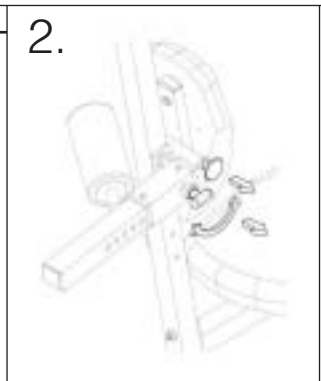
**⚠ WARNING ⚠**

Pay special attention to the plunger on this Pop Pin (65). Always be sure that the plunger is fully engaged into the hole you select. Also, be sure that the spring in the Pop Pin (65) operates freely. Failure to do so may result in serious injury.



**⚠ WARNING ⚠**

Pay special attention to the plunger on both Pop Pins (63) and (65). Always be sure that the plunger is fully engaged into the hole you select. Also, be sure that the spring in both Pop Pins (63) and (65) operates freely. Failure to do so may result in serious injury.



## 3. SEAT PAD (AD) ADJUSTMENT

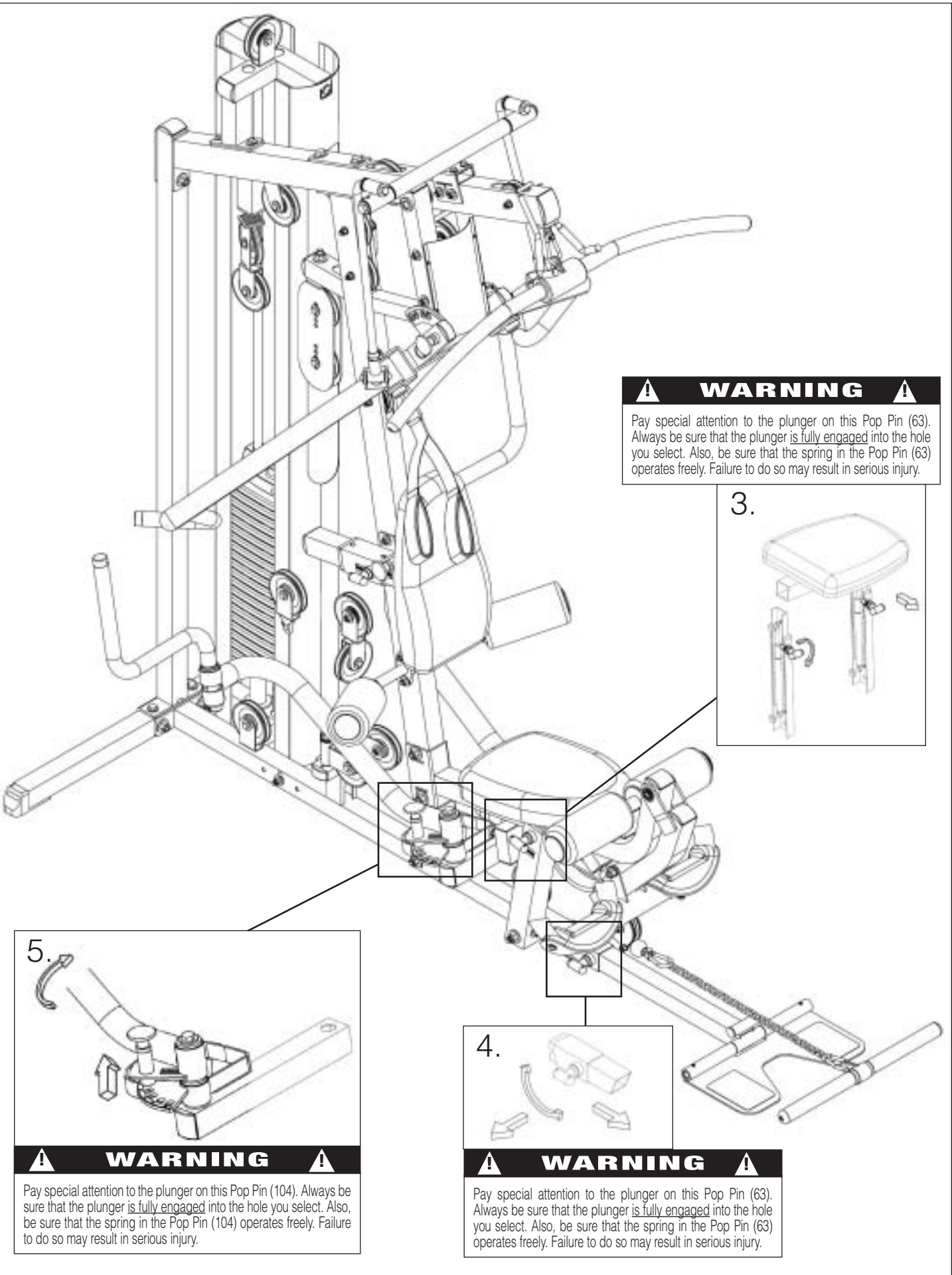
- A. Grasp the Seat Pad (AD).
- B. Turn the T-Shaped Pop Pin (63) in Leg Extension Frame (W) counter clockwise to unlock it, and then pull the Pop Pin to release the Seat Pad Frame (W).
- C. Adjust the Seat Pad (AD) to the desired position.
- D. Release the T-Shaped Pop Pin and make sure it is fully engaged into the selector hole. Turn T-Shaped Pop Pin (63) clockwise to lock it in place.

## 4. FOOT BRACE (AE) ADJUSTMENT

- A. Grasp the Foot Brace Adjuster (AE).
- B. Turn the T-Shaped Pop Pin (63) in Main Base Frame (A) counter clockwise to unlock it, then pull to release the Foot Brace Adjuster (AE).
- C. Adjust to the desired position.
- D. Release the T-Shaped Pop Pin and make sure that it is fully engaged into the selector hole in the Foot Brace Adjuster (AE). Turn clockwise to lock in place.

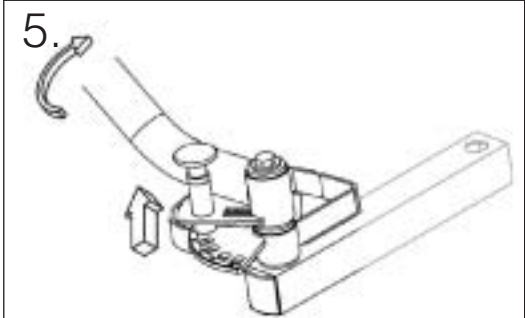
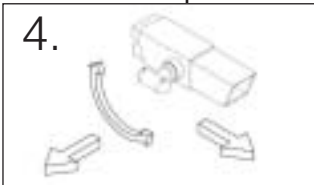
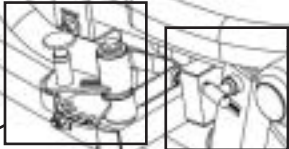
## 5. PEC DEC ARMS (Q),(T) ADJUSTMENT

- A. Grasp Pec Dec Arm (Q) or (T).
- B. Pull the Flat Pop Pin (106) to release the Pec Dec Arm (Q) or (T).
- C. Adjust the Pec Dec Arm to the desired position.
- D. Release the Ball Head Pop Pin (106) and make sure that it is fully engaged into the selector hole.



**⚠ WARNING ⚠**

Pay special attention to the plunger on this Pop Pin (63). Always be sure that the plunger is fully engaged into the hole you select. Also, be sure that the spring in the Pop Pin (63) operates freely. Failure to do so may result in serious injury.



**⚠ WARNING ⚠**

Pay special attention to the plunger on this Pop Pin (104). Always be sure that the plunger is fully engaged into the hole you select. Also, be sure that the spring in the Pop Pin (104) operates freely. Failure to do so may result in serious injury.

**⚠ WARNING ⚠**

Pay special attention to the plunger on this Pop Pin (63). Always be sure that the plunger is fully engaged into the hole you select. Also, be sure that the spring in the Pop Pin (63) operates freely. Failure to do so may result in serious injury.

# Warning, Safety & Maintenance

Be sure that all users carefully read and understand all warning, safety and maintenance labels on the machine before each use. Failure to do so may result in serious injury. It is imperative that you retain this Owner's Manual and be sure all warning labels are legible and intact. Replacement Owner's Manuals and labels are available from your local Body-Solid dealer. If you have any questions about the operation, set up or maintenance of this machine please call our customer service department at 1 (800) 556-3113.

<b>MAINTENANCE SCHEDULE</b>		D	W
Check the function and integrity of the following components. As noted, inspect equipment before each workout. Replace all damaged, broken or worn components immediately.			
Cables:	Check tension, end fittings, and coating	✓	
	Check that locking nut of weight stack is tight		✓
Upholstery:	Wipe down and dry	✓	✓
	Clean and condition		✓
Frame:	Wipe down and dry	✓	✓
	Polish / Wax		✓
Chrome:	Wipe down and dry	✓	✓
	Polish / Lubricate		✓
Nuts / Bolts / Fasteners:	Tighten and / or adjust as needed		✓
Guide Rods:	Lubricate and clean		✓
Linear Rods:	Lubricate and clean		✓
Seat Sleeves:	Lubricate and clean		✓
Adjustments / Locking Pins / Tightening Knobs			✓
Weight Stack Pins			✓
Warning Instruction Labels			✓
Springs / Pop Pins		✓	
Anti Skid Surfaces			✓
Hand Grips / Rollers			✓
For Body-Solid Customer Service <b>Call 1-800-556-3113</b> #ASST123003			

**#DWSM-5**  
Warning Label for Maintenance

**THERE IS A RISK ASSUMED BY INDIVIDUALS WHO USE THIS TYPE OF EQUIPMENT. TO MINIMIZE RISK, YOU MUST FOLLOW THESE RULES:**

1. Inspect equipment before each workout. Check that all nuts, bolts, screws and pop pins are in place and fully tightened. Also, before use, check cables for signs of wear. Replace all worn parts immediately. Never use machine if any parts are damaged or missing.
- FAILURE TO FOLLOW THESE RULES MAY RESULT IN SERIOUS INJURY.**
2. Keep clear of the cables and all moving parts when the machine is in use.
3. Always make sure all Snap Links are closed when doing any cable/pulley/strap exercises.
4. Exercise with care. Perform your exercises at a smooth moderate pace; never perform jerky or uncoordinated movements that may cause injury.
5. It is recommended that you should workout with a training partner.
6. Do not allow children or minors to play on or around this equipment.
7. If unsure of proper use of equipment, call your local Body-Solid distributor or the Body-Solid customer service department at 1-800-556-3113.
8. **WARNING:** Consult your physician before starting your exercise program. For your own safety, do not begin any exercise program without proper instruction. RAL8-6-03 WC-54

**#DWRULE-4**  
Warning Label for Rules

## Warning

### Safety and Maintenance of Cables

Although Body-Solid provides the highest quality of materials and workmanship in its products, the fact remains that component parts eventually wear out over time and with use. **This is particularly true with reference to pliable moving parts such as cables.** In spite of any expressed and/or implied warranties, intervening factors such as improper use, unusually heavy use, improper installation, improper alignment, poor maintenance, etc. serve to drastically reduce the usable life and safety of cables.

Be advised that dangerous conditions can arise even during warranty periods and that any expressed and/or implied warranties **Do Not Negate** the owner's responsibility to thoroughly, carefully and daily inspect all cables on this machine.

Serious injury can occur if you are struck by falling weights or moving parts. The risk that you assume by using this type of equipment can be reduced by following a few simple steps:

**Cable inspection should be performed daily.** Inspect all cables, the nylon coating on all cables and the area near the fittings at each end of each cable. **Replace any damaged or worn cables immediately.** Do not allow the machine to be used until damaged or worn cables are replaced.

**Important:** Cables are wear items. It is your responsibility to prevent unexpected breakage. The actual wire strands, the fittings and the nylon coating itself must all be scrutinized. Using or allowing a machine to be used with a suspect cable can result in serious injury.

The nylon coating on a cable is essential for cable life and safety. Visually inspect all cables and pulleys. Look at the cables as they travel around the cams and pulleys. A cable that is wearing may exhibit a "ballooned" or broken coating in the area that passes over the pulley. Damage to the coating is an early warning signal. A cable should be replaced if the nylon coating is missing, is damaged in anyway, has pulled or shrunk from the fittings at the end of the cables, or if it is discolored. Discoloration of the cable coating is an early indication of internal problems such as wear or fraying.

Annual cable replacement (semiannual in multi-user settings) is strongly recommended as an additional precaution. The rate at which cables wear depends on many factors including: number of users, number of repetitions, weight setting, misuse, abuse, etc. Because of this, periodic cable replacement is not a sufficient safeguard against unexpected breakage.

Nothing short of a thorough, careful, daily inspection constitutes an adequate safety program.

## WARNING

### Safety and Maintenance of Cables

**IMPORTANT:** Cables are wear items. It is your responsibility to prevent unexpected breakage. **Cable inspection should be performed daily.** Inspect all cables, the nylon coating on all cables, and the area near the fitting at each end of each cable. **Replace any damaged or worn cable immediately.** Do not allow the machine to be used until damaged or worn cables are replaced. Using or allowing a machine to be used with a suspect cable can result in serious injury. See Owner's Manual for more information.

For Body-Solid Customer Service  
Call 1-800-556-3113

# Warning, Safety & Maintenance

Precision craftsmanship assures Body-Solid's ability to consistently deliver products of the highest standards. Our products have been carefully designed to ensure safe, efficient long term operation.

However, it must be realized that safe use of this equipment requires that owners carefully read and follow the Body-Solid use recommendations, warnings, and maintenance guidelines in this Owners Manual.

Routine inspection and maintenance is of critical importance to ensure the maximum safety and performance of the G6B. Body-Solid uses the highest quality materials available, but wear is inevitable. Therefore, you must carefully inspect your equipment as outlined in the Maintenance Schedule on the next page.

Be advised that dangerous conditions can arise even during a warranty period. A warranty does not negate the owner's responsibility to thoroughly, carefully and daily inspect the machine.

Including maintaining the equipment the owner's responsibility is also to:

- Be sure to always provide adequate supervision to all end-users.
- Be sure to instruct all end-users of proper usage.
- Be sure all supervisors and personal trainers who instruct end-users on equipment use are properly trained and know the function and importance of every adjustment and setting. Also, be sure these trainers provide proper instruction to end-users on the fundamentals of strength training.

## **CABLES:**

- While the machine is not in use. Carefully run your fingers along the cable to feel for thinning or bulging areas. Replace cables immediately at the first sign of damage or wear. Do not use equipment until damaged cable has been replaced.
- Visually inspect the cables for fraying, cracking, peeling or discoloration.
- Check slack in cables and re-adjust cable tension if needed. See pages 38-39.
- Check that the jam nut on the selector rod top bolt is tight.

## **UPHOLSTERY:**

- Wipe down after every workout.
- Periodically take the time to use a mild soap or a mild vinyl upholstery cleaner. Avoid using any abrasive cleaner not intended for use on vinyl.
- Keep sharp or pointed objects out of your pockets and clear of all upholstery.

## **NUTS/BOLTS/FASTENERS:**

- Periodically inspect all nuts and bolts. Tighten if needed. If bolts seem to loosen periodically, use Loctite 242 for a long-term cure.
- Go through a re-tightening sequence periodically to ensure that all hardware is properly tensioned.

## **GUIDE RODS:**

- Wipe clean with a dust free rag. Lubricate with a Silicon or Teflon based lubricant.

## **ADJUSTMENTS / LOCKING PINS / TIGHTENING KNOBS:**

- Check all pieces for signs of visible wear or damage.
- Check springs in Snap Links and Pop Pins for proper tension and alignment.
- If the spring sticks or has lost its rigidity, replace it immediately.

## **ANTI-SKID SURFACES:**

- Replace if they appear worn or become slippery.

## **WARNING INSTRUCTION LABELS:**

- Inspect and familiarize yourself with all safety warnings and other user information on decals.



# Body-Solid®

BUILT FOR LIFE

MAINTENANCE SCHEDULE	DAILY	WEEKLY	LATEST DATE ENTRY						
CABLES: CHECK TENSION, END FITTINGS, AND COATING.	✓								
CHECK THAT JAM NUT ON THE SELECTOR ROD TOP BOLT IS TIGHT.		✓							
UPHOLSTERY: WIPE DOWN AND DRY	✓								
CLEAN AND CONDITION.		✓							
FRAME: WIPE DOWN AND DRY	✓								
POLISH/WAX		✓							
CHROME: WIPE DOWN AND DRY	✓								
POLISH/LUBRICATE		✓							
NUTS/BOLTS/FASTENERS: TIGHTEN AND/OR ADJUST AS NEEDED			✓						
GUIDE RODS: LUBRICATE AND CLEAN			✓						
LINEAR RODS: LUBRICATE AND CLEAN			✓						
SEAT SLEEVES: LUBRICATE AND CLEAN			✓						
ADJUSTMENTS / LOCKING PINS / TIGHTENING KNOBS			✓						
WEIGHT STACK PINS			✓						
WARNING INSTRUCTION LABELS			✓						
SPRINGS / POP PINS	✓								
ANTI-SKID SURFACES			✓						
HAND GRIPS / ROLLERS			✓						

FOR BODY-SOLID CUSTOMER SERVICE:  
**1-800-556-3113**

\*Make several copies of this page to keep track of your maintenance.  
You can print more copies of this page by going to:  
<http://www.bodysolid.com/support/docs.html>

# PHRASES, TERMS, TIPS & GUIDELINES



## BEGINNER'S GUIDELINES

- Work out at least two times a week.
- Include six to eight exercises that train major muscle groups.
- Perform two or three sets of at least eight to 12 repetitions.

### **AEROBIC**

Exercise that primarily uses oxygen to burn fuel at low to moderate levels of intensity. Running and jogging are examples of aerobic exercise.

### **ANAEROBIC**

Exercise that primarily uses the body's stored fuel for energy. Intense weightlifting is an example of an anaerobic exercise.

### **ATROPHY**

Decrease of a muscle caused by the decrease in the size of its cells because of inactivity.

### **BALLISTIC STRETCHING**

A stretching technique that involves a bouncing or bobbing movement during the stretch. The final position is not held. This is not a recommended stretching technique.

### **BREATHING**

Never hold your breath during any part of an exercise. Holding your breath may cause severe intra-thoracic pressure and raise blood pressure leading to dizziness, blackout or other complications. The rule of thumb is to exhale on exertion and inhale on the return part of the exercise.

### **CARDIOVASCULAR**

Referring to the heart, lungs, and other periphery systems involved in the transport of oxygen throughout the body.

### **CHALLENGE YOUR MUSCLES**

All strength training should progress gradually, using increases in weight until your goals are reached. Then, change your workout to include increased reps or a higher weight resistance. Alter the order of your exercises, perform multiple sets or different exercises to maintain results or reach new goals.

### **CHANGE ROUTINE**

Beginner's please note: If you want to make changes in the exercise routine that you do, wait until about the six to eight week point. Advanced lifters may want to change routines to avoid plateaus in gaining size or strength.

### **CIRCUIT TRAINING**

Exercise stations that consist of various combinations of weight training, flexibility, calisthenics, and aerobic exercise.

### **CONCENTRIC MUSCLE ACTION**

The muscle shortens while contracting against resistance.

### **ECCENTRIC MUSCLE ACTION**

The muscle lengthens while contracting against resistance.

### **EXERCISE FREQUENCY**

Exercise each muscle group 2-3 times per week. Allow a minimum of 48 hours rest for each muscle group worked. If you are doing a total-body workout, three training sessions per week, performed on every second day, is adequate.

### **EXERCISE LARGE MUSCLES FIRST**

You should work your large muscle groups first (ie. squat, bench press, lat pulldown) before you exercise your small muscle groups (ie. bicep curls, tricep pressdowns, lateral raises).

### **EXERCISE PROGRAM DURATION**

A weight training routine should take anywhere from 45 minutes to one hour to complete. Add another 20 to 60 minutes when you include stretching, warm-up, aerobics and cool-down.

### **GIVE YOUR MUSCLES A REST**

You'll get the most out of strength training if you give your muscles at least 48 hours rest to recover and rebuild between strength training workouts.

### **HYPERTROPHY**

Enlargement of a muscle caused by an increase in the size of its cells in response to weight training.

### **INTENSITY**

The degree to which the body is worked during exercise.

### **ISOKINETIC EXERCISE**

Resistance is given at a fixed velocity of movement with accommodating intensity. A machine that moves you through an entire range of motion at a preset speed and will not change no matter how much pressure is put forth by the individual.

### **ISOMETRIC EXERCISE**

Contracts the muscle statically without changing its length. Example: Attempting to lift a weight heavier than you can handle, but cannot move.

### **ISOTONIC EXERCISE**

Shortens and lengthens the muscle through a complete range of motion. This defines weight training with full range of motion.

### **MUSCLE FATIGUE**

Fatigue is when you can't possibly do another rep without sacrificing form.

### **MUSCULAR ENDURANCE**

The ability to perform repetitive muscular contractions against some resistance.

### **MUSCULAR STRENGTH**

The maximum force that can be applied by a muscle during a single maximum contraction.

### **OSTEOPOROSIS**

A decrease in bone density.

### **PLYOMETRIC EXERCISE**

A technique that includes specific exercises which encompass a rapid stretch of a muscle eccentrically, followed immediately by a rapid concentric contraction of that muscle for the purpose of facilitating and developing a forceful explosive movement over a short period of time. Examples of these are using medicine balls for upper extremity and depth jumping for lower extremity.

# PHRASES, TERMS, TIPS & GUIDELINES

## STARTING RESISTANCE LEVEL

If you begin weight training at too high a level, you risk serious injury. You will also develop poor form, which will hinder your efforts and discourage you. Use this as a guideline: if you cannot lift the weight eight times with proper form, the weight is too heavy. Similarly, don't choose too light a weight; the last two or three repetitions of your set should be difficult.



### POWER

Power is the rate of performing work. Power during a repetition is defined as the weight lifted times the vertical distance the weight is lifted divided by the time to complete the repetition. Power during a repetition can be increased by lifting the same weight the same vertical distance in a shorter period of time. Power can also be increased by lifting a heavier resistance the same vertical distance in the same period of time as a lighter resistance.

### PROGRESS GRADUALLY

Increase reps before increasing resistance. Reduce rest intervals between sets to increase intensity.

### PROGRESSIVE RESISTANCE

The principle of continually adding more weight to a specific exercise as your muscles become stronger to adapt to the heavier weights.

### PROPER FORM

Focus on the proper motion of the exercise and concentrate on the specific muscles being used. Do not sacrifice proper form to lift heavier weight or to perform more repetitions. Proper form also means lifting in a smooth, fluid motion. If you feel strain elsewhere, you should re-evaluate the amount of weight you are lifting or have a qualified professional critique your exercise motion.

### PROPER POSTURE

Maintaining proper posture will greatly reduce chances of injury and maximize exercise benefit. When standing always keep your feet shoulder-width apart. Do not lock your knees. Locking your knees can put unnecessary strain on them. Keep your back flat and straight, making sure not to twist or arch it in order to complete a repetition.

### PROPER TECHNIQUE

To get the most out of strength training and to reduce the chance of injury, use proper weight training techniques. These include working your muscles through their full range of motion (but not locking any joints), lifting at a speed at which you can control the weight and stop easily if necessary.

### RANGE OF MOTION

Moving through a complete range of motion (ROM) allows the muscles to stretch before contraction and increases the number of muscle fibers being recruited. This produces maximum contraction and force. By working the full ROM, flexibility will be maintained and possibly increased.

### REPETITION

A repetition is one complete movement of an exercise. It normally consists of two phases: the concentric muscle action, or lifting of the resistance, and the eccentric muscle action, or lowering of the resistance.

### REPETITION MAXIMUM (RM)

This is the maximum number of repetitions per set that can be performed at a given resistance with proper lifting technique. Thus, a set at a certain RM implies the set is performed to momentary voluntary fatigue. 1RM is the heaviest resistance that can be used for one complete repetition of an exercise. 10 RM is a lighter resistance that allows completion of 10 (but not 11) repetitions with proper exercise technique.

### REST INTERVAL

Allow a brief pause between sets to give your muscles a chance to partially recover before working them again. For power and muscle size development allow a 3 to 4 minute rest interval between sets. For muscular endurance and definition allow a 30 second rest interval. For strength training allow a 60 to 90 second rest interval.

### RISK SHOULD NOT EXCEED BENEFIT

If the risk of a specific exercise exceeds its potential benefit, it is best to stay on the conservative side. There are several ways to work specific muscle groups. Choose those that provide minimal risk. Ask a fitness professional for guidance.

### ROUTINE

The specific exercises, sets, reps and weight for a specific body part.

### SET

This is a group of repetitions performed continuously without stopping. While a set can be made up of any number of repetitions, sets typically range from 1 to 15 repetitions.

### SMALL MUSCLE GROUP EXERCISE

Single joint movement and isolation exercises (i.e. bicep curls, tricep pressdowns and leg extensions).

### SPEED OF MOVEMENT

Strength training movements should be slow and controlled. Do not use momentum to complete an exercise movement. Momentum puts unnecessary stress on tendons, ligaments and joints. Using momentum in your exercise movements does not develop increased strength.

### STATIC STRETCHING

A stretching technique that involves holding a specific muscle or muscle group at a desired length for a certain period of time. This type of stretching is highly recommended.

### STOP TRAINING IF YOU FEEL PAIN

If you feel pain during a specific exercise stop immediately. Any continuation may aggravate an existing injury. Re-evaluate your routine to make sure that you are doing a proper warm up. Decrease the amount of weight you are lifting. Talk to a qualified personal trainer, health professional or your doctor.

### STRENGTH

Strength is the maximal amount of force a muscle or muscle group can generate in a specified movement pattern at a specified velocity of movement.

### WARM UP

This cannot be stressed enough. Many workout-related injuries can be avoided by a proper warm up routine. Try to do a total body warm up before you start training. A good example of a total body warm up is using a stationary bike, treadmill, elliptical, rowing or skiing machine. It is especially important to warm up specific muscle groups you are going to be using. Your muscles need a 5 to 15 minute warm up as well as a brief cool down. This can be as simple as performing a warm up set of high repetitions and light weight (25% to 50% of your training weight) for each exercise.

### WORKOUT

The routine, specific exercises, weights, sets, and reps for one or more body parts.

# NUTRITION



Good nutrition is a diet in which foods are eaten in proper quantities and with the needed distribution of nutrients to maintain good health. Malnutrition, on the other hand, is the result of a diet in which there is an underconsumption, overconsumption, or unbalanced consumption of nutrients that leads to disease or an increased susceptibility to disease. What is stated in the above definitions is the fact that proper nutrition is essential to good health. A history of poor nutritional choices will eventually lead to poor health consequences.

There are many substances necessary for the proper functioning of the body. Nutrients are the substances that the body requires for the maintenance of health, growth, and to repair tissues. Nutrients can be divided into six classes: carbohydrates, fats, proteins, vitamins, minerals and water. Carbohydrates, or "carbs", are nutrients that are composed of carbon, hydrogen and oxygen, and are essential sources of energy in the body. Grains, vegetables, and fruits are excellent sources of carbohydrates. It is recommended that at least 55% to 60% of the total number of calories consumed come from carbohydrates (American Diabetes Association, Diabetes & Exercise, 1990). It is further recommended that 10% or less of the total calories consumed come from simple sugars like a candy bar.

One of the many benefits of consuming foods that are high in complex carbohydrates, such as rice, pasta, and whole grain breads, is that they also typically contain dietary fiber. Dietary fiber is a term used when referring to substances found in plants that cannot be broken down by the human digestive system. Although fiber cannot be digested, it is important in helping to avoid cancers of the digestive system, hemorrhoids, constipation, and diverticular disease because it helps food move quickly and easily through the digestive system. It is recommended that people consume 20 to 30 grams of fiber per day (American Diabetes Association, Diabetes & Exercise, 1990). Excellent sources of dietary fiber are grains, vegetables, legumes, and fruit.

Fats are an essential part of a healthy diet and serve vital functions in the human body. Among the functions performed by fats are temperature regulation, protection of vital organs, distribution of some vitamins, energy production, and formation of component parts of cell membranes. Like carbohydrates, fats are composed of carbon, hydrogen, and oxygen. However, their chemical structure is different.

Both animals and plants provide sources of fat. Saturated fats come primarily from animal sources and are typically solid at room temperature. Plant sources of saturated fats are palm oil, coconut oil, and cocoa butter. A high intake of saturated fats is

directly related to increased cardiovascular disease. Unsaturated fats are typically liquid at room temperature. Corn, peanut, canola, and soybean oil are sources of unsaturated fats. It is recommended that no more than 30% of one's diet be composed of fats. Ten percent or less of the total calories consumed should come from saturated fats. One way to reduce saturated fat intake would be to substitute margarine for butter.

Proteins are substances composed of carbon, hydrogen, oxygen, and nitrogen. Proteins are made by combining amino acids. Amino acids are nitrogen-containing building blocks for proteins that can be used for energy. Amino acids can combine in innumerable ways to form proteins, and it is estimated that tens of thousands of different types of proteins exist in the body. It is the ordering of the amino acids that provides the unique structure and function of proteins.

There are proteins in both meat products and plant products. Animal sources of protein such as milk, meat and eggs contain the eight essential amino acids (amino acids that the body cannot synthesize and therefore must be ingested). Plant sources of protein such as beans, starchy vegetables, nuts, and grains do not always contain all eight amino acids. Because of this, vegetarians must consume a variety of protein-containing foods. It is recommended that proteins make up 10% to 15% of one's daily calories. This will ensure adequate protein for growth, maintenance, and the repair of cells. Protein requirements for adults are not as high as those recommended for infants, children, and young adults. Note: individuals who are training intensely will have an increase in their protein requirements.

Vitamins are organic substances that are essential to the normal functioning of the human body. Although vitamins do not contain energy to be used by the body, these substances are essential in the metabolism of fats, carbohydrates and proteins. Because of the critical role vitamins play, it is necessary that they exist in proper quantities in the body.

Minerals are inorganic molecules that serve a variety of functions in the human body. The minerals that appear in the largest quantities (calcium, phosphorus, potassium, sulfur, sodium, chloride, and magnesium) are often called macrominerals. Other minerals are also essential to normal functioning of the body, but because they exist in smaller quantities (chromium, iron, copper, fluoride, iodine, manganese, molybdenum, selenium, and zinc) they are called microminerals.

A mineral that is often consumed in inadequate amounts by Americans is calcium. Calcium is a mineral important in the mineralization of bone, muscle contraction, and the transmission of nerve impulses. Osteoporosis is a disease characterized by

a decrease in the total amount of bone mineral in the body and by a decrease in strength of the remaining bone. This condition is most common in the elderly but may also exist in younger people who have diets inadequate in calcium or vitamin D or both.

Iron is another mineral that is often underconsumed by Americans. This is especially true of women. The oxygen-carrying properties of hemoglobin (blood) depend on the presence of iron. Anemia is a condition characterized by a decreased capacity to transport oxygen in the blood, and is also common in those lacking a sufficient amount of iron intake. Red meat and eggs are excellent sources of iron. Additionally spinach, lima and navy beans, and prune juice are excellent vegetarian sources of iron.

Sodium, on the other hand, is a mineral that many Americans over-consume. High sodium intake has been linked with hypertension, as well as high blood pressure. People can substantially reduce their sodium intake by limiting consumption of processed foods and decreasing the amount of salt added to foods when cooking.

In conclusion...don't forget hydration. Water is considered an essential nutrient because of its vital role in the normal functioning of the body. Water contributes approximately 60% of the total body weight and is essential in creating an environment in which all metabolic processes occur. Water is necessary to regulate temperature and to transport substances throughout the body.

## FOLLOW THESE BASIC NUTRITIONAL GUIDELINES FOR GAINS IN STRENGTH AND LEAN MUSCLE MASS:

1. **Choose your foods carefully. Try getting your carbohydrates from sources such as rice, vegetables, beans, whole grains, pasta and fruit. Good protein sources include fish, chicken, turkey, lean meat and low-fat or nonfat dairy products.**
2. **Minimize your fat intake.**
3. **Drink a minimum of 10 eight-ounce glasses of water each day.**
4. **Eat four to six small meals a day, about three hours apart. Small meals are more easily digested and result in greater nutrition absorption.**
5. **Avoid eating junk food and fast food.**
6. **Time your protein intake of 40-55 grams approximately 75 minutes after your workout.**
7. **Immediately following your workout, replenish your glycogen stores with approximately 50-75 grams of carbohydrates.**

For more information on nutrition visit your local library or book store. There are many excellent books available.

## EXERCISE

# PRESCRIPTION



### Sets

Sets are defined as a combination of any number of reps of one exercise. The number of sets used in a workout is directly related to training results. Typically, two to three sets are used by intermediate and advanced lifters to achieve optimum gains in strength. Experts agree that multiple-set systems work best for the development of strength and muscular endurance. Gains will be made at a faster rate by using a multiple-set system than gains achieved through a single-set system. The use of a single set of an exercise is recommended and very effective for individuals who are untrained or just beginning a resistance training program. One-set programs might also be used for simple maintenance once you are in shape. It is important to note that low-volume set programs will increase strength in untrained individuals, but more complex physiological adaptations, such as gains in muscle mass, tone, size, and performance usually requires higher-volume set training for the best results. Multiple sets of an exercise present a more intense training stimulus to the muscles during each set. Once your desired initial fitness level has been achieved, multiple-set performances of the exercise using the proper resistance (with specific rest periods between sets) will take you to the next level of strength training, endurance, and muscular development.

### Resistance Used

The amount of resistance used for a specific exercise is probably the most important variable in resistance training. When designing a resistance training program, a weight for each exercise must be chosen. The use of repetition maximums (RM): the exact resistance that allows only a specific number of repetitions to be performed, is probably the easiest method for determining a resistance. Typically, one uses a training RM target or a RM target zone. Example: If your RM zone is 8 to 12 repetitions and you cannot lift the weight at least 8 times using proper form, the weight is too heavy. On the other hand, if you can easily lift the weight 12 times, the weight is too light. In either case, the weight needs to be changed. As the strength level of the lifter changes over time, the resistance is adjusted so a true RM target or target zone resistance is used.

### Rest Periods Between Sets and Exercises

One frequently overlooked variable in exercise prescription is the length of the rest period between sets and between different exercises. Your desired fitness goals will normally determine the amount of time you allow your body to rest. Exercises involving high repetitions (15 to 20) and a high number of sets (3 to 4) with short rest periods (30 seconds) between sets will raise metabolic demands. This in turn will burn excess body fat and increase muscular endurance. Short rest periods are a characteristic of circuit weight training, and the resistances used are typically lighter. This type of workout is best for trimming body fat and toning muscle. Exercises with heavier resistance and fewer sets usually have a longer resting period between sets. The results of using this method are normally increased muscular strength and mass. If the desired outcome is to gain overall muscle mass, your exercise prescription should lean toward a higher weight resistance doing 2 to 6 repetitions per set, with a rest period of 3 to 4 minutes between each set.

### Rest Periods Between Workouts

The amount of rest between training sessions depends on the recovery ability of the individual. Most experts agree that three workouts per week with one day of rest between sessions allows adequate recovery, especially for the beginner. If the resistance training is not excessive, only moderate amounts of delayed muscular soreness should be experienced one day after the session. As the lifter advances and his or her body is better able to tolerate and recuperate from the resistance exercise sessions, the frequency of training can be increased. Well-conditioned athletes may be capable of, and need training frequencies of 4 to 5 days in a row to improve significantly and achieve their desired goals. When consecutive-training-day sequences are used, it is usually beneficial to do different exercises for the same muscle groups and use different resistances for the exercises. When training is performed on consecutive days, it often involves the use of a split routine (different body parts exercised each day), or a split program (different exercises for the same body part performed each day). There are many books available at the library or your local book store for the intermediate and advanced weight training enthusiast. It is also recommended that you work with a qualified personal trainer to achieve your ultimate goals.

### Order of Exercise

Leaders in the field of strength and conditioning believe that working the larger muscle groups first (chest, back, legs), should take priority over training the smaller muscle groups (biceps, triceps, deltoids, calves). The reason behind this exercise order is that the exercises performed in the beginning of the workout are the ones that are going to require the greatest amount of muscle mass to perform. Hence, exercising the smaller muscle groups first will deplete the body of the energy necessary to stimulate the larger muscle groups. Arm-to-leg ordering allows for some recovery of the arm muscles while the leg muscles are exercised. "Stacking" exercises is a common practice among body builders as a way to attempt to bring about muscle hypertrophy. Stacking is loading up different exercises on the same muscle group (ie. standing bicep curls, preacher curls, one arm concentration curls). The exercise order will have a significant impact on the training stimulus stress level in a training session.

### Scheduling Training

Finding the time to do it is one of the most difficult aspects of a training program. Once you have established a time to workout you should plan a training routine based on what muscles to involve on which day. As previously discussed, the larger muscle groups such as the chest, back, and legs should take priority over working the smaller muscle groups. Give your muscles at least 48 hours (but no more than 72 hours) of rest in between sessions.

## TRAINING TIPS

# FOR BEGINNER'S

### ARE YOU A "BEGINNER" ?

A beginner can be classified as someone who has never touched a weight, may have lifted for a while, but has taken a substantial amount of time off, or has not consistently trained over the last six months. If you happen to fall into any of these categories, pay close attention, because the following information will be detrimental to the start of your training program.



As a beginner, one of the most common mistakes is doing too much. Because beginners often make good gains quickly, many fall into the trap of thinking that more is better. This may be true later in the training equation, but not for the novice. Some of the most common injuries occur as a result of taking on too much, too soon.

One of the questions most frequently asked is, "How much weight should I use?" Determining the weight for each exercise will vary from person to person. The weight for each exercise will be lifted in sets and repetitions. Repetition is defined as one execution of any exercise. A set is a combination of any number of repetitions of one exercise.

Experimentation at each exercise station is a good technique for determining the starting weight for an individual. Take the chest press exercise for example. Performing this exercise with a weight that can be pressed 30 times with ease will not help you achieve any particular goals. Adding the appropriate amount of weight that will allow you to perform a maximum of 8 to 12 repetitions will help you obtain the results you desire.

On the other hand, if you put too much weight on the press bar and press it 4 or 5 times, then common sense will tell you to reduce the weight, wait a few minutes, then try again. Remember, never sacrifice perfect form just for the sake of lifting heavier weight. This is a sure-fire, one-way trip down the road to injury. Making muscles work hard, with proper form is the name of the game.

Now that you understand how to test each station for your starting amount of resistance, you should know which muscles to train first. Training the large muscles groups first, such as your chest, legs, and back, should be done before training your small muscle groups like the arms, shoulders, and calves.

Starting with the large muscle groups will help you achieve and maintain quicker gains. The large muscles groups will require more stimulation and a higher intensity level than the smaller muscle groups. Training your arms with all-out intensity and training your chest immediately afterwards will not leave you with enough energy necessary to properly stimulate the muscle fibers in your chest. Moreover, because the triceps are required in chest press movements, your arm muscles will fail much more quickly than your chest muscles, which will also hold back your chest training.

As a beginner, you will find that your gains will come quickly. The excitement and enthusiasm that comes with these gains may cause you to spend even more time on your gym. Take it easy! Remember, just as too little exercise won't stimulate muscle growth...too much exercise won't either.

You need to give your body plenty of rest, especially if you're still sore from the last workout. This will keep you fresh and growing stronger. **NEVER TRAIN A BODY PART THAT IS STILL SORE FROM THE PREVIOUS WORKOUT.** Performing some flexibility exercises is a good way to keep the blood flowing through the sore area, but do not train these muscles again until you are feeling recovered.

Speaking of soreness, there is something else that you, as a beginner, should be aware of: If you work out - your muscles will get sore. The majority of muscle soreness comes from microtears and a build up of lactic acid in the muscle fibers. This is the result of intense exercise. Muscle soreness can become a problem when the body is pushed too fast and too quickly. As a beginner, tendons, ligaments, joints and tissues have not yet developed the ability necessary to recover from high intensity exercise. A general warm up of stretching and light calisthenics prior to exercise can possibly reduce the amount of post-exercise muscle soreness. A good cool down of stretching and cardio work may also decrease muscle soreness.

Now that we have laid a good foundation of the "do's and don'ts", let's get into something a little more specific. The Beginner's Strength Training Program. One of the best beginner's programs is the three-days-a-week routine. For example, do a whole-body workout on Monday, Wednesday and Friday. Use the other days for rest and recuperation. As previously discussed, you want to start with the large muscle groups first, then move on to the small muscle groups. Perform one exercise per muscle group that consists of 2 or 3 sets of 8 to 12 repetitions. Follow this routine for at least six to eight weeks in order for your body to establish the proper stimulation for growth.

One or two exercises per muscle group may not sound like enough to produce any results, but if you're a beginner - it most definitely will. As you continue to train and your body adapts to your exercise routine and recuperative demands you place upon it, you'll be able to add more sets and exercises to your routine.

Another point that is highly recommended is the assistance of a personal trainer. Through the use of a personal trainer you can learn the mechanics and techniques of exercise, how to use proper form to avoid injury and details on proper nutrition. A good trainer will also provide MOTIVATION.

When choosing a personal trainer, here are some tips: Choose an individual that is certified through an accredited association. This is a good way to ensure that he or she is qualified to give you what you need. Also, take a look at what kind of shape they are in. If you want to be in great shape, look for a trainer who is in great shape. They will know what it takes to get results. Here are a few recommended organizations:

- National Strength & Conditioning (719) 632-6722
- American College of Sports Medicine (317) 637-9200
- National Academy of Sports Medicine (312) 929-5101

### SAMPLE WORKOUT ROUTINE WHEN TRAINING FOR STRENGTH

<b>Exercises</b>	<b>Reps</b>	<b>Sets</b>
Leg Press / Squat	8 to 12	2 or 3
Leg Extension	8 to 12	2 or 3
Leg Curl	8 to 12	2 or 3
Calf Raise	8 to 12	2 or 3
Bench / Chest Press	8 to 12	2 or 3
Incline Press	8 to 12	2 or 3
Incline Pec Fly	8 to 12	2 or 3
Lat Pulldown	8 to 12	2 or 3
Seated Row	8 to 12	2 or 3
Military Press	8 to 12	2 or 3
Upright Row	8 to 12	2 or 3
Bicep Curl	8 to 12	2 or 3
Tricep Pressdown	8 to 12	2 or 3
Tricep Extension	8 to 12	2 or 3
Resistance Ab Crunch	20 to 30	2 or 3
Resistance Oblique Crunch	20 to 30	2 or 3

Rest period between sets should be about 60 to 90 seconds.

*Body-Solid*

# COMMON TRAINING MISTAKES



---

## 1. Lack of Adequate Warm-Up and Inadequate Flexibility

A warmed muscle is a more flexible muscle that's better able to lift heavier weights and work in a full range of motion. Those warmed muscles also greatly reduce your chance of training injuries.

## 2. Improper Form

The use of improper form is a good way to keep you out of the gym. Not only does improper form cause injuries, it also doesn't allow for adequate muscle-fiber stimulation.

## 3. Too Much Weight

Overloading the muscles is a good way to promote muscular growth, but packing on too much weight can cause a snowball effect of improper form, injuries, and down time from your routine.

## 4. Not Enough Weight

Not lifting enough weight will prohibit the stimulation necessary for muscular growth. Keep challenging yourself to lift heavier weights on a progressive basis always maintaining proper form.

## 5. Not Enough Rest Between Workouts

If you're still sore from your previous workout, you don't have to go back at it just because it's your scheduled day. Give your body an extra day off to fully recover so when you return you will be able to give 100%.

## 6. Overtraining

It's not how much time you spend working out, but what you accomplish that really matters. Try to keep your resistance workouts within 45 to 60 minutes per session.

## 7. Poor Diet and Supplementation

Eating the right combination of foods, along with good supplementation, will greatly promote your success. Make your diet 50 percent carbohydrate, 35 percent protein, 15 percent fat, and take a good multivitamin and protein / carbohydrate supplement. Don't forget the water- at least 80 ounces a day! Hydration is critical.

## 8. Stale Routines

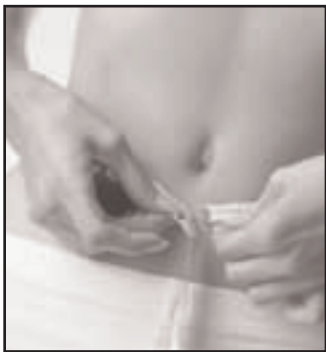
Your body adapts very quickly to the demands placed upon it. That's why you should have a variety of exercises and routines that you can do. To keep your body growing, you've got to keep it off-guard. Changing your exercises and routines is a sure way to do it.

## SETTING UP YOUR PERSONAL PROGRAM



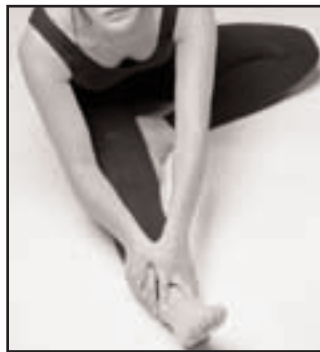
It is important to first establish specific and realistic goals. You should determine your long term goal and then set a series of short term goals that will help you attain your long term goal. The most common goals are:

Once you have determined your personal goals, you will need to set up a schedule that helps you attain them. Set up a schedule that includes the number of workouts per week, the type of workout activity, the time of day for each workout, and the actual workout program. Don't forget to factor in the warm up and cool down periods. You may have to modify your current lifestyle to accommodate your new schedule. It's very important to include the following basic components to achieve successful results:

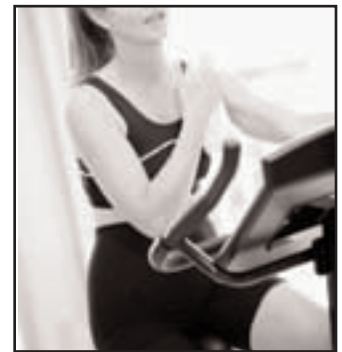


Muscular Endurance & Definition

**If your personal goals involve losing a considerable amount of body fat you will need to focus more on aerobic exercise and weight training**



Stretching



Aerobic Exercise



Increase Strength

**for muscular endurance and definition. If your goals involve a large increase in muscle size you will need to focus on power and muscle mass weight training. Depending on your goals, you will have different nutritional requirements.**



Weight Training



Nutrition



Increase Power & Muscle Mass





# DETERMINE YOUR TRAINING METHOD

There are three basic types of weight training methods:

1. Training for muscular endurance and definition
2. Training for strength
3. Training for power and muscle mass

You should select a training method that reflects both your present fitness level and your long term goals. You should begin carefully and with proper professional guidance. You can always move from one training method to another as you progress.

If you are beginner, you should start slowly and carefully, gradually increasing the frequency and intensity of your training. Always play it safe – be realistic about your goals and your schedule. Realistic goals are safer and easier to follow.

Which is the right training method for you? First, take a look at your present physique and determine your objectives. Do you want a trim, toned, well-defined body? Are you involved in a sport where speed, strength and power are most important? Maybe you want bulging muscles and a terrific V-shape torso so you look great on the beach. Once you make a decision on what the final results should be, you can set up your personal program using the proper training method to achieve your goals.

## Which training method is right for you?

### FOR MUSCULAR ENDURANCE & DEFINITION

This training method incorporates achieving and maintaining a high cardiovascular (heart) rate and helps burn away excess fatty tissue. It also adds muscle definition and muscular endurance to your entire body. Exercises are most commonly performed for 15 to 20 repetitions and 3 to 4 sets using a light to moderate weight. The rest period between sets should be about 30 seconds. These short rest intervals will help maintain an elevated heart rate and prevent the muscles from cooling down.

### FOR STRENGTH

This type of training is the most popular of the three and is designed specifically for increasing strength throughout the muscle and the muscle-tendon junction. This type of training is especially important for athletes. Normally, exercises are performed using moderate to heavy weight for 8 to 12 repetitions and 2 to 3 sets. The rest period between sets should be from 60 to 90 seconds. This allows a degree of muscle recovery before you hit them again.

### FOR POWER AND MUSCLE MASS

This is the method most often used by bodybuilders and is recommended only for the intermediate and advanced lifter. The weights used are heavy — this shocks the muscles and stimulates a more rapid increase in muscle size. Usually exercises are performed for 2 to 6 repetitions and 3 to 4 sets using very heavy weight. The rest period between sets should be from 3 to 4 minutes. The prolonged rest periods allow ample time for recovery between sets.

## DESIGNING YOUR PERSONAL ROUTINE

### FIRST:

You need to decide which of the above training methods is best suited to accomplish your personal goals.

### SECOND:

Study the exercise poster that came with your Body-Solid machine and select one or two exercises per body part (body parts are listed to the left of the exercise pictures). Be sure to include exercises for all body parts. If you leave out certain body parts your exercise routine and your body will not be balanced. If you are trying to increase muscle mass or increase strength to a muscle group it is alright to add extra exercises to the area you are particularly concerned about.

### THIRD:

Coordinate your body part exercise program and your personal schedule. If you select one exercise per body part you can normally do your entire routine in the same workout. If you choose to do more than 12 exercises you may decide to divide your workout routine into upper and lower body exercises. You can split your schedule to work upper body one day and lower body the next day. Remember to rest each particular muscle group 48 hours before working it again.

### FOURTH:

Order the exercises in your routine so you are working the large muscle groups first and the small muscle groups last.

### FIFTH:

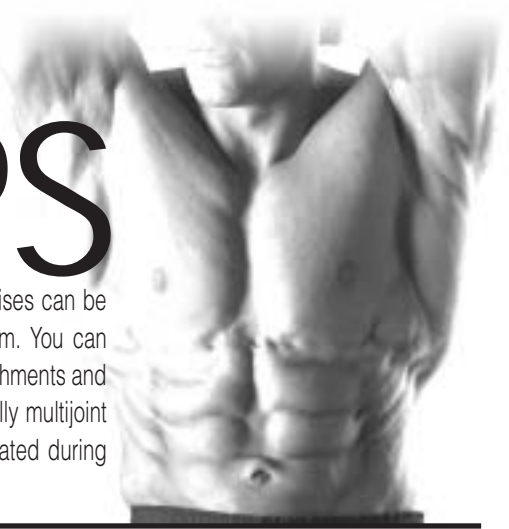
Keep a record! Write down the exercises, number of sets, number of reps and the amount of resistance (weight).

### BEGINNER'S SAMPLE WORKOUT ROUTINE WHEN TRAINING FOR DEFINITION

Exercise	Reps	Sets
Bench / Chest Press	15 to 20	3 or 4
Lat Pulldown	15 to 20	3 or 4
Shoulder Press	15 to 20	3 or 4
Tricep Pressdown	15 to 20	3 or 4
Bicep Curl	15 to 20	3 or 4
Leg Press/Squat	15 to 20	3 or 4
Leg Extension	15 to 20	3 or 4
Leg Curl	15 to 20	3 or 4
Calf Raise	15 to 20	3 or 4
Ab Crunch	20 to 30	3 or 4

Rest period between sets should be about 30 seconds.

# EXERCISE TIPS



Listed below are Body-Solid's picks of the best exercises you can do for each body part. These exercises can be done using free weights, machines and multi-station gyms. Learn to do each exercise in proper form. You can make substitutions in your training and try variations of each using different Body-Solid grips, cable attachments and accessories to slightly change the emphasis of a particular exercise. Note: Many movements, especially multijoint exercises, work more than one muscle group. For example, your front deltoids and triceps are stimulated during bench / chest pressing movements.

## CHEST

This powerful muscle group is the cornerstone of a well-developed upper body. To most thoroughly work your pecs, include both pressing and fly movements and vary the angle of the bench from decline to flat to incline.

**BENCH / CHEST PRESS**  
**INCLINE PRESS**  
**DECLINE PRESS**  
**PEC FLY**  
**INCLINE FLY**  
**DECLINE FLY**  
**CABLE CROSSOVER**  
**DIPS**

## SHOULDERS

The shoulder joint, which has the greatest range of motion of all joints in the body, is best worked by training all three deltoid heads. Include a pressing movement followed by a raise for each of the three heads.

**SHOULDER PRESS**  
**BEHIND THE NECK PRESS**  
**FRONT DELTOID RAISE**  
**LATERAL (SIDE) DELTOID RAISE**  
**BENT-OVER LATERAL DELTOID RAISE**  
**REVERSE PEC-FLY**

## UPPER BACK

A powerful upper back is marked by both middle-back thickness and width (the sought-after V-taper). This is best achieved by combining various rows with pull-downs and pull-ups. Remember to vary your grip to slightly change the stimulus.

**PULL UP**  
**UPRIGHT ROW**  
**LAT PULLDOWN**  
**SEATED ROW**  
**BENT OVER ROW**  
**HIGH ROW**  
**REVERSE GRIP PULLDOWN**

## TRAPS

A signature muscle of a strong upper back, well-developed traps help prevent neck injury. Shrug movements should be done with heavy weights in a straight up-and-down motion.

**STRAIGHT BAR SHRUG**  
**DUMBBELL SHRUG**  
**BEHIND THE BACK SHRUG**  
**UPRIGHT ROW**

## LOWER BACK

Important not only for spinal protection but also because it's the seat of power for many exercises. If you spend a great deal of time crunching for abs, you need to balance your training for complete development and muscular balance.

**PULL UP**  
**UPRIGHT ROW**  
**LAT PULLDOWN**  
**SEATED ROW**  
**BENT OVER ROW**  
**HIGH ROW**  
**REVERSE GRIP PULLDOWN**

## TRICEPS

This three-headed muscle on the back of your arm is involved in extension of the elbow. Like the biceps, the triceps cross the elbow and shoulder joints. Because of this, you can and should work the triceps through a variety of angles to ensure complete development.

**LYING TRICEPS EXTENSION**  
**CABLE TRICEPS EXTENSION**  
**CABLE TRICEPS PRESSDOWN**  
**CLOSE-GRIP BENCH PRESS**  
**REVERSE-GRIP PRESSDOWN**  
**TRICEPS PRESS**  
**DIPS**

## BICEPS / FOREARMS

A two-headed muscle, the biceps' primary focus is to flex your elbow and supinate your wrist. The ability to build your biceps peak is largely genetic, but exercises that maximally stress the short head will help.

**BICEPS**  
**STANDING BICEP CURL**  
**SEATED BICEP CURL**  
**INCLINE CURL**  
**PREACHER CURL**  
**CONCENTRATION CURL**  
**ONE-ARM CABLE CURL**  
**FOREARMS**  
**WRIST CURL**  
**REVERSE WRIST CURL**

## ABDOMINALS

The rectus abdominus has upper and lower regions, but you can't isolate one area over the other. Still, include both upper and lower ab movement to more strongly emphasize those areas, and do twisting movements to work the obliques for complete development.

**UPPER AB REGION**  
**CABLE AB CRUNCH**  
**DECLINE BENCH CRUNCH**  
**LOWER AB REGION**  
**REVERSE CRUNCH**  
**HANGING KNEE RAISE**  
**HIP THRUST**  
**OBLIQUES**  
**CABLE SIDE BEND**  
**OBLIQUE CRUNCH**

## THIGHS / GLUTES

The main muscles of the thighs are the quadriceps which are composed of four muscles. You have several others near the hip joint, including the body's largest muscle group, the gluteals. Multijoint movements (in which action occurs at both the hip and knee joints) are your best choice to work these muscles.

**BACK SQUAT**  
**FRONT SQUAT**  
**LEG PRESS**  
**LUNGE**  
**REVERSE LUNGE**  
**STEP-UP**  
**LEG EXTENSION** (does not work glutes)

## HAMSTRINGS

On the back of the thighs, the hamstrings balance the quads and allow for a wide range of movement. Good exercise choices include those that work the hamstrings and both the hip and knee joints.

**DEADLIFT**  
**STIFF-LEGGED DEADLIFT**  
**GOOD MORNING**  
**LYING LEG CURL**  
**SEATED LEG CURL**  
**ONE-LEGGED STANDING LEG CURL**

## CALVES

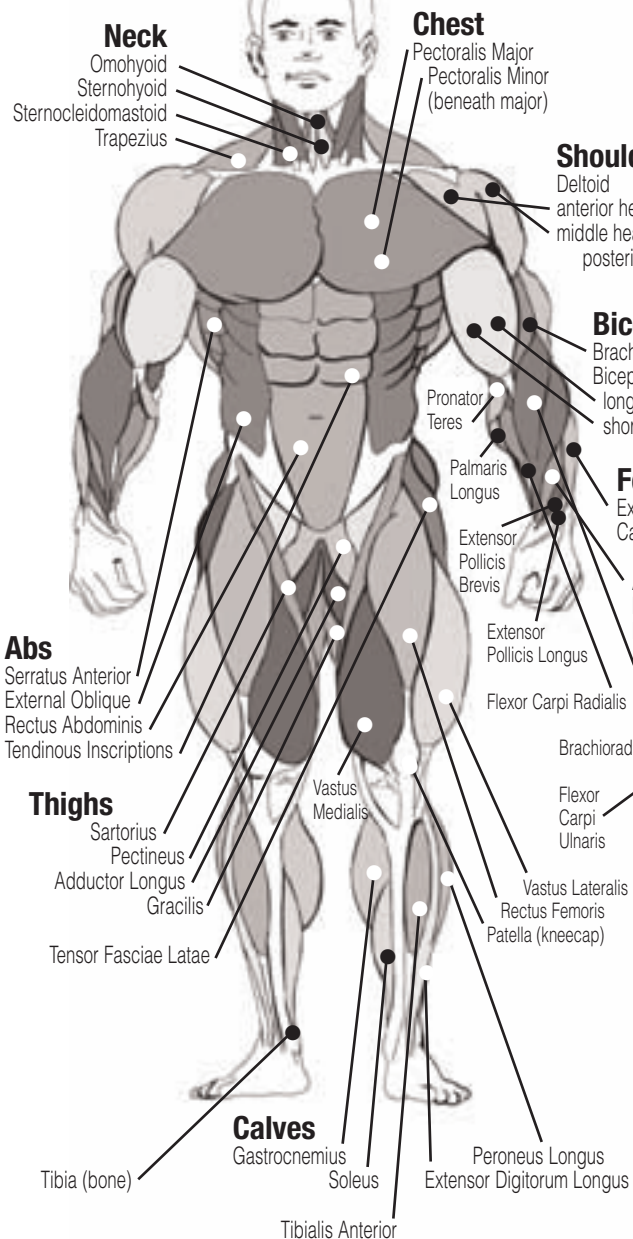
Calves consist of two major muscles, the gastrocnemius and soleus. The latter is best worked when the knee is flexed, as in the seated calf raise.

**STANDING CALF RAISE**  
**SEATED CALF RAISE**  
**DONKEY CALF RAISE**  
**LEG PRESS CALF RAISE**  
**HACK SQUAT CALF RAISE**

# ANATOMY CHART

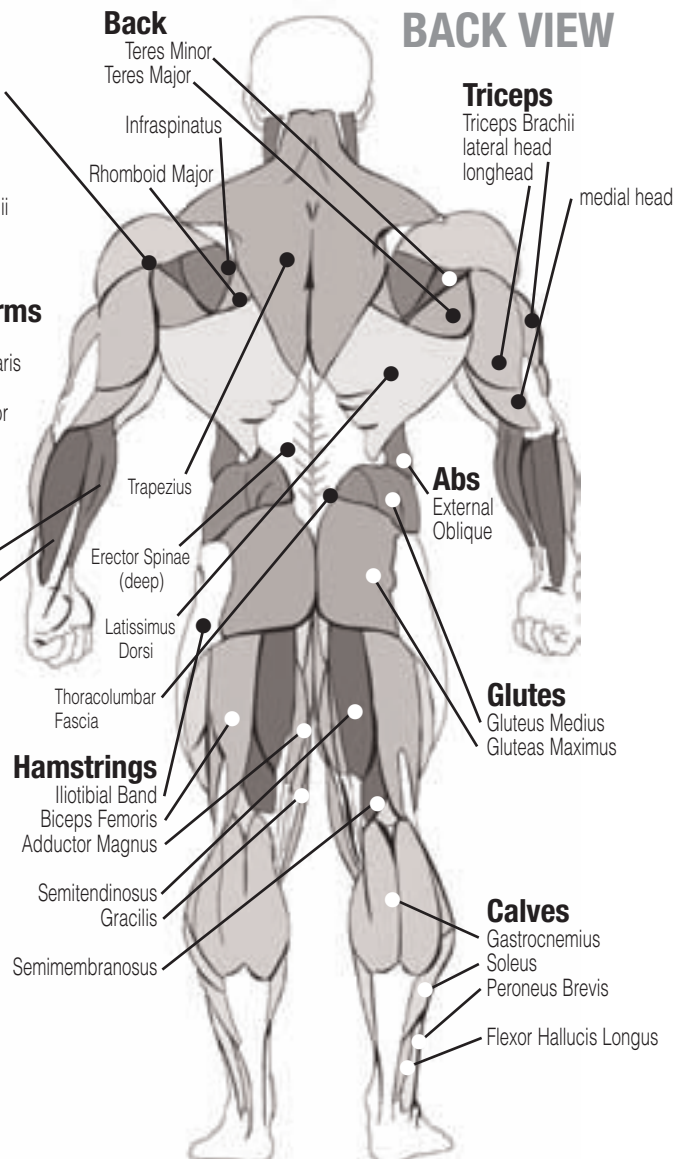


## FRONT VIEW



**Note:** These illustrations depicting exaggerated musculature are not in the textbook anatomical position. As such, they are inexact for medical purposes but are useful for a general understanding.

## BACK VIEW





## SHORT-TERM GOALS

Date Set \_\_\_\_\_ Date Accomplished \_\_\_\_\_

Goal \_\_\_\_\_

\_\_\_\_\_

\_\_\_\_\_

Reward\*\* \_\_\_\_\_

Date Set \_\_\_\_\_ Date Accomplished \_\_\_\_\_

Goal \_\_\_\_\_

\_\_\_\_\_

\_\_\_\_\_

Reward\*\* \_\_\_\_\_

Date Set \_\_\_\_\_ Date Accomplished \_\_\_\_\_

Goal \_\_\_\_\_

\_\_\_\_\_

\_\_\_\_\_

Reward\*\* \_\_\_\_\_

## LONG-TERM GOALS

Goal \_\_\_\_\_

\_\_\_\_\_

\_\_\_\_\_

\_\_\_\_\_

Reward! \_\_\_\_\_

\_\_\_\_\_

\_\_\_\_\_

\* Make several copies of this page to keep track of your goals and accomplishments.  
You can print more copies of this page by going to <http://www.bodysolid.com/support/docs.html>  
\*\* Don't forget to reward yourself for a job well-done!



# WEIGHT TRAINING EXERCISE LOG

Date	S			R			W								
	S	R	W	S	R	W	S	R	W						
Exercise															
BENCH / CHEST PRESS															
LAT PULLDOWN															
SHOULDER PRESS															
TRICEP PRESSDOWN															
BICEP CURL															
LEG PRESS / SQUAT															
LEG EXTENSION															
LEG CURL															
CALF RAISE															
AB CRUNCH															
TOTALS															

**S = Sets**  
**R = Repetitions per set**  
**W = Weight used**

**BEGINNER'S SAMPLE WORKOUT ROUTINE**

Keep track of your changes and improvements. It's a great motivational tool!\*

\* Make several copies of this page to keep track of your progress. You can print more copies of this page by going to <http://www.bodysolid.com/support/docs.html>

# WEIGHT TRAINING EXERCISE LOG



Date	S			R			W					
	S	R	W	S	R	W	S	R	W			
Exercise												
LEG PRESS / SQUAT												
LEG EXTENSION												
LEG CURL												
CALF RAISE												
BENCH / CHEST PRESS												
INCLINE PRESS												
INCLINE PEC FLY												
LAT PULLDOWN												
SEATED ROW												
MILITARY PRESS												
UPRIGHT ROW												
BICEP CURL												
TRICEP PRESSDOWN												
TRICEP EXTENSION												
RESISTANCE AB CRUNCH												
RESISTANCE OBLIQUE CRUNCH												
TOTALS												

**S = Sets**  
**R = Repetitions per set**  
**W = Weight used**

**SAMPLE WORKOUT ROUTINE WHEN TRAINING FOR STRENGTH**  
 Keep track of your changes and improvements. It's a great motivational tool!\*

\* Make several copies of this page to keep track of your progress.  
 You can print more copies of this page by going to <http://www.bodysolid.com/support/docs.html>



## WEIGHT TRAINING EXERCISE LOG

**S = Sets**  
**R = Repetitions per set**  
**W = Weight used**

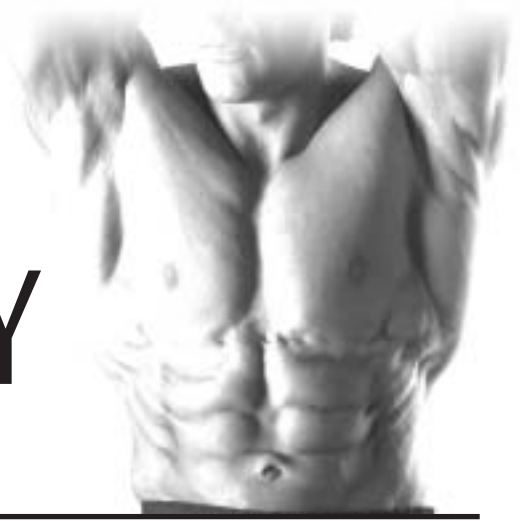
**INTERMEDIATE AND ADVANCED LIFTERS...** Design your personal strength training program. Keep track of your changes and improvements. It's a great motivational tool!\*

Date	Exercise	S		R		W		S		R		W		S		R		W		
		S	R	S	R	S	R	S	R	S	R	S	R	S	R	S	R	S	R	W
<b>TOTALS</b>																				

\* Make several copies of this page to keep track of your progress. You can print more copies of this page by going to <http://www.bodysolid.com/support/docs.html>

# Body-Solid

# STRETCHING & FLEXIBILITY



Flexibility is an important component of physical fitness and needs to be addressed in a resistance training program. The two main purposes for stretching are injury prevention and a faster rate of recovery from exercise. Stretching should be performed in both the warm up and cool down phases of a training session. A good general guideline is that each workout session should be preceded by 5 to 15 minutes of general warm up, followed by 8 to 12 minutes of stretching, and concluded with 4 to 5 minutes of post-exercise stretching.

A regular stretching program will loosen muscle tissue, allowing an increased range of motion. This helps prevent microtears at the muscle-tendon junction. Almost 90% of all injuries from muscle strain occur at the muscle-tendon junction. Repeated injury at this junction can lead to a build-up of scar tissue, which impedes range of motion and adds stress to the joints.

Begin by stretching the major muscle groups first. Move in and out of your stretches with smooth, slow, controlled motion. Hold the stretch for at least 10 seconds when you feel you have reached your muscle's maximum distance. Do not use fast, hurried or reckless motions when stretching. Fast and bouncy motions will increase the risk of injury.

The most common and most popular type of stretching is the **static stretching** technique. This form of stretching involves voluntary, complete relaxation of the muscles while they are elongated. A static stretch is a constant, steady stretch in which the end position is held for 10 to 30 seconds. This technique is popular because it is easy to learn, effective, and accompanied by minimal soreness with the least risk of injury.

**Ballistic stretching** involves a bouncing or bobbing movement during the stretch. The final position in the movement is not held. Ballistic stretching is unpopular because of the increased amount of delayed muscle soreness and the possibility of injury during the stretching exercise. Ballistic stretching is not recommended.

A dynamic stretch involves flexibility during sport specific movements. **Dynamic stretching** is similar to ballistic stretching in that it utilizes movement, but dynamic stretching includes movements that may be specific to a sport or movement pattern. Dynamic stretching is most common among track and field athletes, but is also used in other sports, such as basketball and volleyball. An example of dynamic stretching would be a track sprinter performing high knees with an emphasis on knee height and arm action, not on horizontal speed.

**The following pages show illustrations with descriptions of static stretching for warm up and post-exercise cool down. Remember... stretch your large muscle groups first and do all stretches in a smooth, slow, controlled manner.**





## UPPER BACK

### Cross Arm in Front of Chest

MUSCLE(S) AFFECTED: *latissimus dorsi and teres major*

1. Stand or sit with the right arm slightly flexed (15° to 30°) and adducted across the chest.
2. Grasp the upper arm just above the elbow, placing the left hand on the posterior side of the upper arm.
3. Pull the right arm across the chest (toward the left) with the left hand.
4. Hold for 10 seconds.
5. Repeat with the left arm.



Stretching the upper back

## UPPER BACK

### Arms Straight Up Above Head (Pillar)

MUSCLE(S) AFFECTED: *latissimus dorsi and wrist flexors*

1. Stand with arms in front of torso, fingers interlocked with palms facing each other.
2. Slowly straighten the arms above the head with palms up.
3. Continue to reach upward with hands and arms.
4. While continuing to reach upward, slowly reach slightly backward.
5. Hold for 10 seconds.



Stretching the shoulders, chest and upper back

## LOWER BACK

### Spinal Twist (Pretzel)

MUSCLE(S) AFFECTED: *internal oblique, external oblique and spinal erectors*

1. Sitting with legs straight and upper body nearly vertical, place right foot on left side of left knee.
2. Place back of left elbow on right side of right knee, which is now bent.
3. Place right palm on floor 12 to 16 inches behind hips.
4. Push right knee to the left with left elbow while turning shoulders and head to the right as far as possible. Try to look behind the back.
5. Hold for 10 seconds.
6. Repeat with left leg.



Stretching the low back and sides

## LOWER BACK

### Semi-Leg Straddle

MUSCLE(S) AFFECTED: *spinal erectors*

1. Sitting, knees flexed 30 to 50 degrees, let the legs totally relax.
2. Point the knees outward; the lateral side of the knees may or may not touch the floor.
3. Lean forward from waist and reach forward with extended arms. Hold position for 10 to 15 seconds.
4. Bending and relaxing legs decreases hamstring involvement and increases lower back stretch.



Stretching the low back from seated position



## SIDES

### Side Bend with Straight Arms

**MUSCLE(S) AFFECTED:** *external oblique, latissimus dorsi and serratus anterior*

1. Stand with feet 14 to 16 inches apart.
2. Interlace the fingers with palms facing each other.
3. Reach upward with straight arms.
4. Keeping arms straight, lean from waist to left side. Do not bend knees.
5. After moving as far as possible, hold for 10 seconds.
6. Repeat to the left side.



Stretching  
the sides, upper  
back and shoulders

## SHOULDER

### Seated Lean-Back

**MUSCLE(S) AFFECTED:** *deltoids and pectoralis major*

1. Sitting with legs straight and arms extended, place palms on floor about 12 inches behind hips.
2. Point fingers away (backward) from body.
3. Slide hands backward and lean backward.
4. Hold for 10 seconds.



Stretching shoulder  
joints—sitting

## CHEST

### Straight Arms Behind Back

**MUSCLE(S) AFFECTED:** *deltoids and pectoralis major*

1. Standing, place both arms behind back.
2. Interlock fingers with palms facing each other.
3. Straighten arms fully.
4. Slowly raise the straight arms.
5. Hold for 10 to 15 seconds.
6. Keep head upright and neck relaxed.



Stretching the chest

**Remember... do all stretches in a smooth, slow, controlled manner.**



## POSTERIOR OF THIGH

### Sitting Toe Touch

**MUSCLE(S) AFFECTED:** *hamstrings, spinal erectors and gastrocnemius*

1. Sit with the upper body nearly vertical and legs straight.
2. Lean forward from waist and grasp toes with each hand, slightly pull toes towards the upper body, and pull chest towards leg. (If you are very stiff, try to grasp the ankles.) Hold for 10 seconds.
3. Release toes and relax foot.
4. Grasp ankles and continue to pull chest towards legs. Hold for 10 seconds.
5. Still grasping the ankles, point away from body and continue to pull chest towards legs. Hold for 10 seconds.



Stretching the hamstrings with emphasis on insertion of the hamstrings and calves.



Stretching the hamstrings with emphasis on the middle portion.



Stretching the hamstrings with emphasis on the upper portion.

## GROIN

### Butterfly

**MUSCLE(S) AFFECTED:** *adductors and sartorius*

1. Sitting with the upper body nearly vertical and legs straight, flex both knees as the soles of the feet come together.
2. Pull feet toward body.
3. Place hands on feet and elbows on legs.
4. Pull torso slightly forward as elbows push legs down.
5. Hold for 10 to 15 seconds.



Stretching the groin



## GROIN

### Straddle (Spread Eagle)

**MUSCLE(S) AFFECTED:** *gastrocnemius, hamstrings, spinal erectors, adductors and sartorius*

1. Sit with the upper body nearly vertical and legs straight, and spread legs as far as possible.
2. With right hand, grasp toes of right foot and pull on toes slightly, while pulling chest toward right leg. Hold for 10 seconds.
3. Release toes and relax foot.
4. Grasp ankle and continue to pull chest toward right leg. Hold for 10 seconds.
5. Point toes away from body and continue to pull chest toward right leg. Hold for 10 seconds.
6. Repeat process with the left leg.
7. Repeat process by grasping right toes with right hand and left toes with left hand. Move the torso forward and toward the ground.



Stretching the hamstrings and groin with emphasis on insertion of the hamstrings and calves



Stretching the hamstrings and groin with emphasis on the upper portion



Stretching the groin, low back and hamstrings



## POSTERIOR OF LOWER LEG

### Step Stretch

MUSCLE(S) AFFECTED: *gastrocnemius and soleus; also, achilles tendon*

1. Have ready a step or board 3 to 4 inches high.
2. Place balls of both feet on the step or board, 1 inch from its edge.
3. With straight legs, lower heels as far as possible.
4. Hold for 10 to 15 seconds.
5. To stretch achilles tendon, raise heels slightly. Slightly flex the knees and then lower the heels.  
This stretch will be felt in the achilles tendon.
6. Hold for 10 to 15 seconds.
7. For a more intense and individualized stretch, perform this stretch with one leg at a time.



Stretching the calves standing on a step



Preparing to stretch the achilles tendon by slightly bending the knee



Stretching the achilles tendon by lowering the heel



# Body-Solid WORKOUT



## C H E S T

### Chest Press

*(Pectorals)*

1. Insert pin into weight stack at desired resistance level.
2. Adjust seat pad height so that when seated the horizontal press handles bisect the upper chest (pectoral major) muscles.
3. Seat yourself comfortably on the seat pad with your back straight.
4. Grasp bench handles with your arms bent and palms facing down.
5. Keeping your elbows out and below your shoulders, extend your arms forward at a smooth, moderate pace through out the exercise movement.
6. Pause for a moment, then slowly return to the starting position, repeat movement.
7. Exhale on exertion, inhale on return motion.



### Incline Press

*(Upper Pectorals)*

1. Insert pin into weight stack at desired resistance level.
2. Set Press Arms to the Incline Press position and set back pad to the Incline Press position.
3. Adjust seat pad height so that when seated the horizontal press handles bisect the upper chest (pectoral major) muscles.
4. Sit comfortably on the seat pad with your back flat against the back pad.
5. Grasp horizontal bench handles with your arms bent and palms facing downward.
6. Keeping your elbows out and below your shoulders, extend your arms forward at a smooth, moderate pace throughout the exercise movement.
7. Pause for a moment, then slowly return to the starting position, repeat movement.
8. Exhale on exertion, inhale on return motion.



### Pectoral Fly

*(Pectorals)*

1. Insert pin into weight stack at desired resistance level.
2. Adjust seat pad height so that when seated and grasping handles your upper arms are parallel with the floor.
3. Sit comfortably on the seat pad facing away from the machine and your back flat against the back pad.
4. Grasp handles with arms slightly bent and upper arms parallel with the floor.
5. Use Chest (pectoral) muscles to bring your arms forward and toward each other until the pec arms touch.
6. Pause for a moment, then slowly return to the starting position. Repeat movement.
7. Exhale on exertion, inhale on return motion.



### Cable Crossover

*(Pectorals)*

1. Insert pin into weight stack at desired resistance level.
2. Attach utility strap to low pulley cable.
3. Stand with your right side facing the low pulley and your feet set shoulder width apart. Grasp the strap with your right hand. Bend slightly at the waist and maintain this torso angle throughout the exercise movement.
4. Keeping your palm facing toward your body and arm slightly bent, pull strap upward and across your body in a semicircular arc until it is approximately level with your shoulder.
5. Pause for a moment, then slowly return the strap, back along the same arc, to the starting position. Repeat movement.
6. Exhale on exertion, inhale on return motion.
7. Turn around and repeat with opposite arm.





# Body-Solid WORKOUT



## B A C K

### Lat Pulldown

*(Latissimus Dorsi)*

1. Insert pin into weight stack at desired resistance level.
2. Attach Lat Bar to high pulley cable.
3. Adjust seat pad so your knees fit comfortably under leg hold-down foam rollers. Sit on seat pad facing into machine.
4. Grasp Lat Bar 3 to 6 inches wider than your shoulders, on each side.
5. Keeping your elbows back during movement, slowly pull the Bar down until it lightly touches the upper part of your chest.
6. Pause for a moment, then slowly return to the starting position. Repeat movement.
7. Exhale on exertion, inhale on return motion.



### Seated Row

*(Latissimus Dorsi)*

1. Insert pin into weight stack at desired resistance level.
2. Attach Low Row Bar to low pulley cable.
3. Sit on the floor with your knees slightly bent and your feet placed firmly against the foot brace.
4. Grasp the Bar in both hands. Straighten your arms and lean towards the pulley to completely stretch your Lats.
5. Simultaneously pull the Bar toward you and sit erect, being sure to keep your elbows close to your sides. Continue to pull the Bar until it touches your midsection.
6. Pause for a moment, then slowly return to the starting position. Repeat movement.
7. Exhale on exertion, inhale on return motion.



### Bent-Over Row

*(Latissimus Dorsi)*

1. Insert pin into weight stack at desired resistance level.
2. Attach Low Row Bar to low pulley cable.
3. Set your feet shoulder width apart, grasp the Low Row Bar with both hands, palms facing away from the machine.
4. Straighten your arms and bend your legs slightly. Keeping your back straight, bend at the waist until your torso is at a 45° angle.
5. Keeping your elbows out, pull the Bar upward and slightly back until it touches your lower midsection.
6. Pause for a moment, then slowly return to the starting position. Repeat movement.
7. Exhale on exertion, inhale on return motion.



### Shrugs

*(Trapezius)*

1. Insert pin into weight stack at desired resistance level.
2. Attach Low Row Bar to low pulley cable.
3. Stand, facing the machine with your feet set shoulder width apart.
4. Grasp the Bar and stand erect with your arms extended straight down and the Bar resting across your thighs. Allow the weight to pull your shoulders forward and downward.
5. Use Trapezius strength to "shrug" your shoulders upward and back as far as possible.
6. Pause for a moment, then slowly return to the starting position. Repeat movement.
7. Exhale on exertion, inhale on return motion.





# Body-Solid WORKOUT



## A R M S

### Standing Cable Curl

*(Biceps)*

1. Insert pin into weight stack at desired resistance level.
2. Attach Low Row Bar to low pulley cable.
3. Take an underhand grasp on the Bar. Stand erect with your feet set at shoulder width, approximately 1 to 2 feet away from pulley. Your arms should be down at your sides with the Bar resting on your thighs.
4. Keeping your upper arms locked against the sides of your torso, use Biceps strength to curl the Bar upward and forward in a semicircular arc to a position beneath your chin.
5. Pause for a moment, then slowly return the bar back along the same arc, to the starting position. Repeat movement.
6. Exhale on exertion, inhale on return motion.



### Concentration Curl

*(Biceps)*

1. Insert pin into weight stack at desired resistance level.
2. Attach Stirrup Handle (optional) to low pulley cable.
3. Take an overhand grasp on the Stirrup Handle with your right hand. Stand approximately 1 to 2 feet back from the pulley with your feet at shoulder width. Bend slightly at the waist. Keep your right upper arm locked against the side of your torso.
4. Use Biceps strength to curl the Handle forward and upward in a semicircular arc toward your chest.
5. Pause for a moment, then slowly return the Handle back along the same arc, to the starting position. Repeat movement.
6. Exhale on exertion, inhale on return motion.
7. Change hands and repeat with opposite arm.



### Tricep Pressdown

*(Triceps)*

1. Insert pin into weight stack at desired resistance level.
2. Attach Low Row Bar to high pulley cable.
3. Stand erect with your feet shoulder width. Take an overhand grasp of the Low Row Bar with your hands set 3 to 5 inches apart.
4. Pull the Bar down and lock your upper arms against the sides of your torso where they must remain throughout the exercise. Lean slightly forward at the waist.
5. Moving only your forearms, use Triceps strength to press the Bar down in a semicircular arc to a position below your waist.
6. Pause for a moment, then slowly return the Bar back along the same arc, to the starting position. Repeat movement.
7. Exhale on exertion, inhale on return motion.



### Seated Tricep Extension

*(Triceps)*

1. Insert pin into weight stack at desired resistance level.
2. Attach Triceps Strap to middle pulley cable.
3. Sit on seat pad, facing away from the machine. Reach behind your head and grasp the Triceps Strap.
4. Bend at the waist so that your torso is at an approximate 45° angle. Keep your hands behind your head and your arms bent with your elbows facing forward.
5. Keeping your upper arms motionless, use Triceps strength to move the Triceps Strap forward and upward in an arcing motion until your arms are fully extended.
6. Pause for a moment, then slowly return the strap back along the same arc, to the starting position. Repeat movement.
7. Exhale on exertion, inhale on return motion.







# Body-Solid WORKOUT



## SHOULDERS

### Deltoid Raise

*(Deltoids)*

1. Insert pin into weight stack at desired resistance level.
2. Attach Stirrup Handle (optional) to low pulley cable.
3. Take an overhand grasp of the Stirrup Handle with your left hand and your palm facing down.
4. With your right side toward the machine, stand in front of the machine.
5. Using shoulder muscle strength, slowly raise the Stirrup Handle upward in a semicircular arc until it is in a position slightly above your shoulder level.
6. Pause for a moment, then slowly return the Handle along the same arc, back to the starting position. Repeat movement.
7. Exhale on exertion, inhale on return motion.
8. Change hands and repeat with opposite arm.



### Shoulder Press

*(Deltoids)*

1. Insert pin into weight stack at desired resistance level.
2. Set Press Arms to the Shoulder Press position and set back pad to the Shoulder Press position.
3. Adjust seat pad height so that when seated the horizontal press handles bisect the shoulder (deltoid) muscles.
4. Sit comfortably on the seat pad with your back flat against the back pad.
5. Grasp the Press Arm Handles with your arms bent and palms facing downward.
6. Keeping your elbows out, extend your arms forward at a smooth, moderate pace throughout the exercise movement.
7. Pause for a moment, then slowly return to the starting position. Repeat movement.
8. Exhale on exertion, inhale on return motion.



### Upright Row

*(Deltoids & Trapezius)*

1. Insert pin into weight stack at desired resistance level.
2. Attach the Low Row Bar to low pulley cable.
3. Take an overhand grasp of the Bar with your hands approximately 6 inches apart.
4. Facing the machine, stand 1 to 2 feet away from the pulley with your feet set shoulder width apart. Allow the weight to extend your arms downward with the bar resting across your thighs.
5. Keeping your elbows above your hands at all times, slowly pull the bar upward until the backs of your hands are even with your chin.
6. Pause for a moment, then slowly return to the starting position. Repeat movement.
7. Exhale on exertion, inhale on return motion.





# Body-Solid WORKOUT



## LEGS

### Standing Leg Curl

*(Hamstrings)*

1. Insert pin into weight stack at desired resistance level.
2. Stand facing machine and hook your left heel under the bottom roller pad with left knee positioned slightly below the top roller pad. Grasp back pad or seated press handles for stability.
3. Use Hamstring strength to pull and curl your left foot upward, bending your knee as much as possible.
4. Pause for a moment, then slowly return along the same arc, to the starting position. Repeat movement.
5. Exhale on exertion, inhale on return motion.
6. Change sides and repeat with opposite leg.



### Leg Extension

*(Quadriceps)*

1. Insert pin into weight stack at desired resistance level.
2. Adjust seat pad height so that when seated the front of your ankles fit under the bottom foam rollers.
3. Sit comfortably on seat pad. Place knees over the top roller pads and hook your feet under the bottom roller pads.
4. Using Quadriceps strength, extend your feet out and upward until your legs are fully extended.
5. Pause for a moment, then slowly return your feet back along the same arc, to the starting position. Repeat movement.
6. Exhale on exertion, inhale on return motion.



### Leg Abduction

*(Outer Thigh)*

1. Insert pin into weight stack at desired resistance level.
2. Attach Ankle Strap to left ankle and low pulley cable. Stand 1 to 2 feet away from the pulley with your right side toward machine.
3. Keeping your legs straight and your body balanced, allow the weight to pull your leg across your body and toward the machine.
4. Using Outer Thigh strength, slowly pull your left leg across and out from your body as far as possible.
5. Pause for a moment, then slowly return along the same arc, to the starting position. Repeat movement.
6. Exhale on exertion, inhale on return motion.
7. Turn around and repeat with opposite leg.



### Leg Adduction

*(Inner Thigh)*

1. Insert pin into weight stack at desired resistance level.
2. Attach Ankle Strap to right ankle and low pulley cable. Stand 1 to 2 feet away from the pulley with your right side toward machine.
3. Keeping your legs straight and your body balanced, allow the weight to pull your leg away from your body and toward the machine.
4. Using Inner Thigh strength, slowly pull your right leg across and out from your body as far as possible.
5. Pause for a moment, then slowly return along the same arc, to the starting position. Repeat movement.
6. Exhale on exertion, inhale on return motion.
7. Turn around and repeat with opposite leg.





# Body-Solid WORKOUT



## A B S

### Ab Crunch

*(Abdominals)*

1. Insert pin into weight stack at desired resistance level.
2. Attach Triceps Strap to the middle pulley cable.
3. Sit comfortably on seat pad with your back resting against back pad. Grasp the Triceps Strap and place it over your shoulders, keeping your hands planted firmly on your upper chest throughout the entire exercise movement.
4. Using Abdominal muscle strength, slowly bend forward at the waist as far as possible.
5. Pause for a moment, then slowly return back to the starting position. Repeat movement.
6. Exhale on exertion, inhale on return motion.



### Oblique Bend

*(Obliques & Abdominals)*

1. Insert pin into weight stack at desired resistance level.
2. Attach Stirrup Handle (optional) to low pulley cable.
3. Take an overhand grasp of the Handle with your right hand and stand 1 to 2 feet away from the pulley with your right side toward the machine.
4. Keeping your arm, legs and hips straight, bend your torso away from the machine.
5. Pause for a moment, then slowly return to the starting position. Repeat movement.
6. Exhale on exertion, inhale on return motion.
7. Turn around and repeat with opposite hand.



## Signs Of Overtraining

In the quest for better health and fitness, it is sometimes difficult to quell one's enthusiasm and take a break from exercise. But if exercise is leaving you more exhausted than energized, you could be suffering from an acute case of overtraining. Individuals who excessively exercise are risking more than poor performance; they're risking their health. If you recognize the following symptoms in yourself or a friend, it is essential that you seek professional help.

---

### Here are signs of overtraining:

#### **DECREASED PERFORMANCE.**

Slower reaction times, reduced speeds and lowered endurance levels are all common signs of overtraining.

#### **AGITATION, MOODINESS, IRRITABILITY OR LACK OF CONCENTRATION.**

Too much exercise and too little rest can wreak havoc on the hormones, cause mood swings and create an inability to concentrate.

#### **EXCESSIVE FATIGUE AND MALAISE.**

A body that never has a chance to fully recover from a previous workout will continue to feel more and more fatigued. Some people describe this feeling as "heavy legs."

#### **INCREASED PERCEIVED EFFORT DURING NORMAL WORKOUTS.**

Overtraining takes a toll on the body, and workouts that were once a breeze can begin to feel like a grind.

#### **CHRONIC OR NAGGING MUSCLE ACHES OR JOINT PAIN.**

Overused muscles and joints can cause constant aches, which may go unnoticed until the body is given proper rest.

#### **MORE FREQUENT ILLNESSES AND UPPER-RESPIRATORY INFECTIONS.**

Too much exercise taxes all of the body's systems and makes it more difficult to ward off infections.

#### **INSOMNIA OR RESTLESS SLEEP.**

During sleep the body has time to rest and repair itself. An overtrained body, however, is sometimes unable to slow down and completely relax, making it difficult to recover between workouts.

#### **LOSS OF APPETITE.**

Overtraining can cause an increase in hormones such as epinephrine and norepinephrine that tend to inhibit appetite. The physical exhaustion and anxiety that often comes with overtraining can also have the same effect.

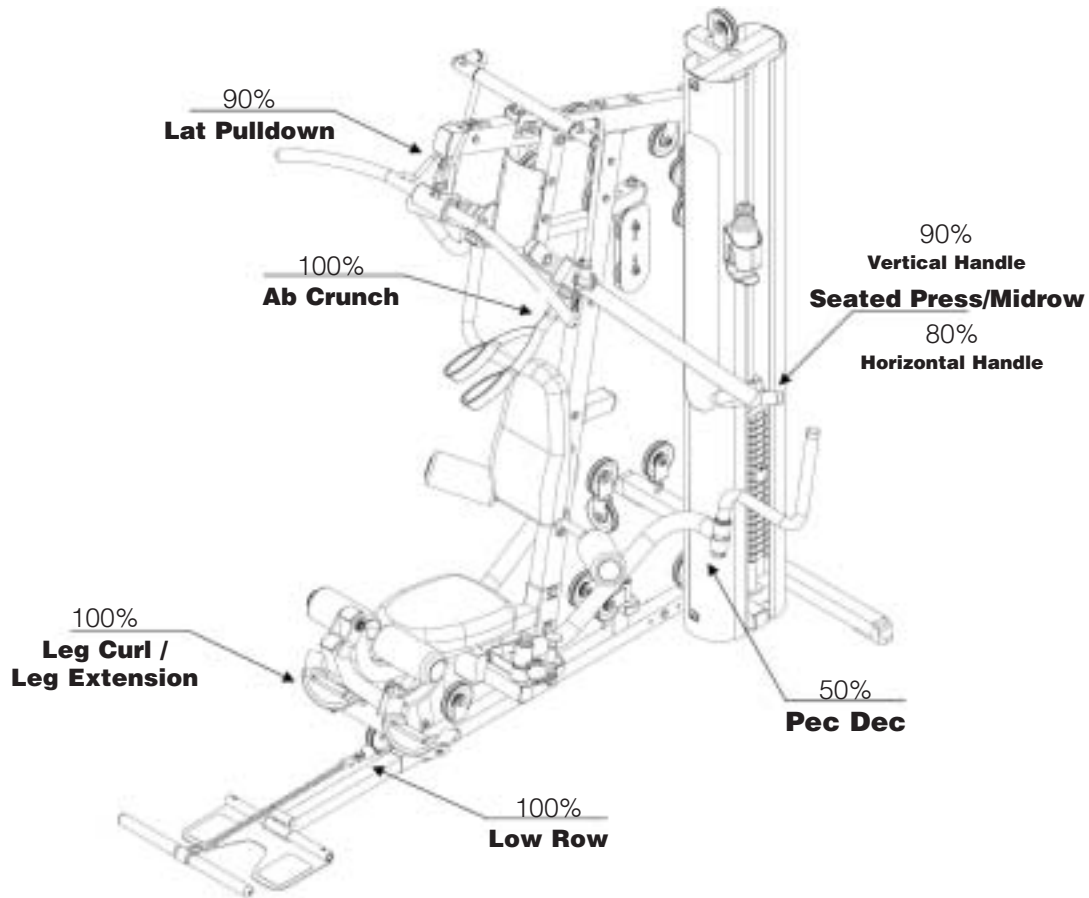
#### **CHRONICALLY ELEVATED HEART RATE AT REST AND DURING EXERCISE.**

A clear sign of an overworked heart muscle is a chronically elevated heart rate. Also, people who overtrain will often find that it takes longer for their heart rate to return to normal after a workout.

#### **MENSTRUAL CYCLE DISTURBANCES IN WOMEN.**

Exercising excessively and not consuming enough calories may disrupt a woman's menstrual cycle. While some may experience irregular periods, others will stop menstruating altogether.

# Weight Ratios



	50%	80%	90%	100%
Top Plate 1	5 lbs.	8 lbs.	9 lbs.	10 lbs.
2	10	16	18	20
3	15	24	27	30
4	20	32	36	40
5	25	40	45	50
6	30	48	54	60
7	35	56	63	70
8	40	64	72	80
9	45	72	81	90
10	50	80	90	100
11	55	88	99	110
12	60	96	108	120
13	65	104	117	130
14	70	112	126	140
15	75	120	135	150
16	80	128	144	160
17	85	136	153	170
18	90	144	162	180
19	95	152	171	190
20	100	160	180	200
21	105	168	189	210

## Weight Plates

**This chart shows the actual weight you are lifting.**

**To use this chart;** count the number of plates you have pinned, and move across to the correct weight ratio (depending on the exercise you are performing).

# BUILD THE ULTIMATE FITNESS CENTER

with *Body-Solid*



**Vertical Knee Raise / Dip / Push-Up / Chin Machine**  
#VKR82

**40" Wide 3-Tier Dumbbell Rack**  
#WDR363

**45° Hyperextension Machine**  
#WHYP45

**Rubber Flooring**  
#RF46

## Accessories

**Olympic Weight Tree**  
#WT46

**Strength Training Time Clock**  
#STT45

**Pentathlon Treadmill**  
#T7iHRC

**Elliptical Machine**  
#E4

**100% Covered LIFETIME WARRANTY**

CALL NOW FOR THE DEALER NEAREST YOU 1-800-833-1227  
OR VISIT OUR WEB SITE AT: [www.bodysolid.com](http://www.bodysolid.com)

## O b t a i n i n g   S e r v i c e

Please retain this Owner's Manual for future reference. When ordering parts you must use the part number and description from this Owner's Manual. Use only Body-Solid replacement parts when servicing this machine. Failure to do so will void your warranty and could result in personal injury.

For more information about product operation or service, check out the official Body-Solid website at [www.bodysolid.com](http://www.bodysolid.com) or contact an authorized Body-Solid dealer or a Body-Solid factory authorized service company or contact Body-Solid customer service at one of the following:

Toll Free: 1-800-833-1227  
Phone: 1-708-427-3555  
Fax: 1-708-427-3556  
E-mail: [service@bodysolid.com](mailto:service@bodysolid.com)

Or write to: Body-Solid, Inc.  
Service Department  
1900 S. Des Plaines Ave.  
Forest Park, IL 60130 USA

### Ordering replacement parts

When ordering replacement parts, please have the following information available:

1. Model number:     G6B
2. Date of purchase: \_\_\_\_\_
3. Name of dealer: \_\_\_\_\_  
\_\_\_\_\_
4. Dealer location: \_\_\_\_\_  
\_\_\_\_\_  
\_\_\_\_\_  
\_\_\_\_\_
5. Part numbers (see pages 80-85): \_\_\_\_\_  
\_\_\_\_\_
6. Description of part: \_\_\_\_\_  
\_\_\_\_\_  
\_\_\_\_\_

## G 6 B Mainframe Parts List

KEY#	QTY	PART#	DESCRIPTION
A	1	G6BMBF-A	MAIN BASE FRAME
B	1	G6BRBF-B	REAR BASE FRAME
C	1	G6BRVF-C	REAR VERTICAL FRAME
D	1	G6BASF-D	ANGLED SUPPORT FRAME
E	1	G6BTF-E	TOP FRAME
F	2	G6BGR-F	GUIDE RODS
G	1	G6BTWSF-G	TOP WEIGHT STACK FRAME
H	1	G6BSPAS-H	SEATED PRESS ARM SUPPORT
J	1	G6BBAB-J	BI-ANGULAR BARS
JA	1	G6BBAS-JA	BI-ANGULAR SHAFT
JB	1	G6BBAF-JB	BI-ANGULAR FRAME
JC	1	G6BBARA-JC	BI-ANGULAR RIGHT ARM
JD	1	G6BBALA-JD	BI-ANGULAR LEFT ARM
LE	1	G6BBARJ-LE	BI-ANGULAR RIGHT JUNCTION
JF	1	G6BBALJ-LF	BI-ANGULAR LEFT JUNCTION
JG	1	G6BBARP-JG	BI-ANGULAR RIGHT PIVOT
JH	1	G6BBALP-JH	BI-ANGULAR LEFT PIVOT
K	1	G6BPAH-K	PRESS ARM HOLDER
KA	1	G6BLS-KA	LEFT SHAFT
KB	1	G6BRS-KB	RIGHT SHAFT
L	1	G6BLPA-L	LEFT PRESS ARM
LA	1	G6BLPAP-LA	LEFT PRESS ARM PIVOT
M	1	G6BRPA-M	RIGHT PRESS ARM
MA	1	G6BRPAP-MA	RIGHT PRESS ARM PIVOT
N	1	G6BPDF-N	PEC DEC FRAME
P	1	G6BLPDC-P	LEFT PEC DEC CAM
Q	1	G6BLPDA-Q	LEFT PEC DEC ARM
R	1	G6BLPDH-R	LEFT PEC DEC HANDLE
S	1	G6BRPDC-S	RIGHT PEC DEC CAM
T	1	G6BRPDA-T	RIGHT PEC DEC ARM
U	1	G6BRPDH-U	RIGHT PEC DEC HANDLE
V	1	G6BLEF-V	LEG EXTENSION FRAME
W	1	G6BSPF-W	SEAT PAD FRAME
X	1	G6BLEA-X	LEG EXTENSION ARM
Y	1	G6BLEPH-Y	LEG EXTENSION PAD HOLDER
AB	1	G6BPP-AB	PULLEY PLATFORM
AC	2	G6BPS-AC	PULLEY SWIVEL
AE	1	G6BFBA-AE	FOOT BRACE ADJUSTER
AF	1	G6BFB-AF	FOOT BRACE
AG	1	G6BRLHD-AG	RIGHT LEG HOLD DOWN
AH	1	G6BLLHD-AH	LEFT LEG HOLD DOWN
BA	1	G6BBPH-BA	BACK PAD HOLDER
BC	1	G6BBPF-BC	BACK PAD FRAME
BD	1	G6BBPA-BD	BACK PAD ADJUSTER

**Part numbers are required when ordering parts.**



## P a d s L i s t

<b>KEY#</b>	<b>QTY</b>	<b>PART#</b>	<b>DESCRIPTION</b>
AA	2	G6BLEP-AA	LEG EXTENSION PADS
AD	1	G6BSP-AD	SEAT PAD
BB	1	G6BBP-BB	BACK PAD

## P u l l e y H o l d e r L i s t

<b>KEY#</b>	<b>QTY</b>	<b>PART#</b>	<b>DESCRIPTION</b>
CA	1	G6BDPH-CA	DOUBLE PULLEY HOLDER
CB	1	G6B45DPH-CB	45 DEGREE PULLEY HOLDER
CC	1	G6B90DPH-CC	90 DEGREE PULLEY HOLDER
CD	1	G6BSPH-CD	SINGLE PULLEY HOLDER

## S h r o u d L i s t

<b>KEY#</b>	<b>QTY</b>	<b>PART#</b>	<b>DESCRIPTION</b>
DA	1	G6BWSS-DA	WEIGHT STACK SHROUD
DB	1	G6BSI-DB	SHROUD INSERT
DC	1	G6BBWSS-DC	BACK WEIGHT STACK SHROUD

**Part numbers are required when ordering parts.**

## G 6 B Hardware List

KEY#	QTY	PART#	DESCRIPTION
1	4	JSNAP3	SNAP LINK 3 1/4"
2	9	JCEC2X2	CONVEX END CAP 2" X 2"
3	9	JCEC1X2	CONVEX END CAP 1" X 2"
4	1	JCEC2X3	CONVEX END CAP 2" X 3"
5	2	JPREC2.5	PLASTIC ROLLER END CAP 2.5" OD X 1" ID
6	4	JFC2X2	FOOT CAP 2" X 2"
7	2	JSC.75	SHAFT COLLAR 3/4"
8	2	JNW3	NYLON WASHER 3"
9	2	JREC2	ROUND END CAP 2"
10	2	JFL22	FRAME LEVELER 2" X 2"
11	2	JWSS22	WEIGHT STACK SHIMS 2" X 2"
12	1	JRP1.5X1.5	RUBBER PAD 1 1/2" X 1 1/2"
13	1	JRP1.5X3	RUBBER PAD 1 1/2" X 3"
14	2	JRD2.5	RUBBER DONUT 2 1/2"
15	2	JEC1.5X3	END CAP 1 1/2" X 3"
16	4	JGT3.75X5.5	GRIP TAPE 3 3/4" X 5 1/2"
17	1	JTP10	TOP PLATE 10lbs
18	4	JFR4X8	FOAM ROLLER 4" X 8"
19	1	JSR25	SELECTOR ROD
20	4	JREC1X1.5	ROUND END CAP 1" X 2 1/2" L
21	21	JPP4.25	PLASTIC PULLEY 4 1/4" O.D.
22	3	JPP3.5	PLASTIC PULLEY 3 1/2" O.D.
23	1	JSC	STEEL CHAIN
26	2	JOW1X1..37	OILITE WASHER 1" I.D. X 1 3/8" O.D.
27	2	JREC1	ROUND END CAP 1"
28	2	JCEC2X2	CONVEX END CAP 2" X 2"
29	1	JEC1X2	END CAP 1" X 2"
30	2	JPREC	PLASTIC ROLLER END CAP
31	2	JNB2X2	NYLON BUSHING 2" X 2"
33	1	JS.75X7	SHAFT 3/4" O.D. X 7" L
34	12	JAS.31X.31	ALLEN SCREWS 5/16" X 5/16"
35	1	JS1X9.75	SHAFT 1" O.D. X 9 3/4" L
36	4	JRAB.37X.62	ROUND ALLEN BOLT 3/8" X 5/8" FULL THREAD
37	8	JHEX.5X.75PTB	HEX HEAD BOLT 1/2" X 3/4" PARTIAL THREAD
38	20	JSP10	WEIGHT STACK PLATE (10lbs.)
39	1	JFRB	FOAM ROLLER BAR
40	12	JHEX.5X3.25PTB	HEX HEAD BOLT 1/2" X 3 1/4" PARTIAL THREAD
41	1	JHEX.5X3.5PTB	HEX HEAD BOLT 1/2" X 3 1/2" PARTIAL THREAD
42	3	JHEX.5X3.75PTB	HEX HEAD BOLT 1/2" X 3 3/4" PARTIAL THREAD
43	2	JHEX.5X4.25PTB	HEX HEAD BOLT 1/2" X 4 1/4" PARTIAL THREAD
44	1	JHEX.5X5.5PTB	HEX HEAD BOLT 1/2" X 5 1/2" PARTIAL THREAD
45	2	JFAB.31X.75FTB	FLAT ALLEN BOLT 5/16" X 3/4" FULL THREAD

**Part numbers are required when ordering parts.**

## G 6 B Hardware (continued)

KEY#	QTY	PART#	DESCRIPTION
46	2	JCC1X1.37	CHROME COLLAR 1" I.D. 1 3/8" O.D.
47	1	JS.5X3	SHAFT 1/2" X 3"
48	2	JOB.5	OILITE BUSHING 1/2" I.D.-leg extension pad holder (Y)
49	2	JRAHB.31X.5	ROUND ALLEN HEAD BOLT 5/16" X 1/2"
50	8	JHEX.37X1PTB	HEX HEAD BOLT 3/8" X 1" PARTIAL THREAD
51	22	JHEX.37X1.75PTB	HEX HEAD BOLT 3/8" X 1 3/4" PARTIAL THREAD
52	4	JHEX.37X2.75PTB	HEX HEAD BOLT 3/8" X 2 3/4" PARTIAL THREAD
53	7	JHEX.37X3PTB	HEX HEAD BOLT 3/8" X 3" PARTIAL THREAD
54	2	JHEX.37X7.25PTB	HEX HEAD BOLT 3/8" X 7 1/4" PARTIAL THREAD
55	2	JCB.37X2.75PTB	CARRIAGE BOLT 3/8" X 2 3/4" PARTIAL THREAD
56	2	JHEX.37X3.25PTB	HEX HEAD BOLT 3/8" X 3 1/4" PARTIAL THREAD
57	1	JHEX.37X2.5PTB	HEX HEAD BOLT 3/8" X 2 1/2" PARTIAL THREAD
58	1	JSHA.37X2FTB	SOCKET HEAD ALLEN BOLT 3/8" X 2" FULL THREAD
59	4	JRA.37X.62FTB	ROUND ALLEN BOLT 3/8" X 5/8" FULL THREAD
60	2	JHEX.31X1.5FTB	HEX HEAD BOLT 5/16" X 1 1/2" FULL THREAD
61	4	JAHB.31X.75FTB	ALLEN HEAD BOLT 5/16" X 3/4" FULL THREAD
62	2	JHEX.31X1.75PTB	HEX HEAD BOLT 5/16" X 1 3/4" PARTIAL THREAD
63	3	JTSP3	T-SHAPED POP PIN 3"
64	1	JS16	SHAFT 16" LENGTH
65	1	JTSP7	T-SHAPED POP PIN 7"
66	1	JFAHB.31X.5	FLAT ALLEN HEAD BOLT 5/16" X 1/2"
67	1	JFP6	FLAT PLATE 6"
68	1	JFP6.75	FLAT PLATE 6 3/4"
70	9	JNLN.5	NYLON LOCK NUT 1/2"
71	46	JNLN.37	NYLON LOCK NUT 3/8"
73	31	JWFLT.5	WASHER 1/2"
74	48	JWFLT.37	WASHER 3/8"
75	2	JSLW.37	SPRING LOCK WASHER 3/8"
76	8	JWFLT.31	WASHER 5/16"
77	8	JSLW.31	SPRING LOCK WASHER 5/16"
78	10	JWFLT.37	WASHER 3/8"
80	2	JHEX.31X.75PTB	HEX HEAD BOLT 5/16" X 3/4" PARTIAL THREAD
81	1	JPIN4.25	WEIGHT STACK PIN 4.25 LENGTH
83	4	JSS.37X.75	STEEL SLEEVE 3/8" X 3/4"
84	10	JPS.37	PULLEY SPACER 3/8"

**Continued on next page**



**Part numbers are required when ordering parts.**

## G 6 B Hardware (continued)

KEY#	QTY	PART#	DESCRIPTION
89	4	JRAHB.37X.62	ROUND ALLEN HEAD BOLT 3/8" X 5/8"
90	4	JRAHB.12X.37	ROUND ALLEN HEAD BOLT 1/8" X 5/8"
94	1	JFPP3.75	FLAT POP PIN 3 3/4"
95	1	JWSPL	WEIGHT STACK PIN LANYARD
96	4	JCC1X1.37	CHROME COLLAR 1" I.D. X 1 3/8" O.D.
97	8	JAS.19X.19	ALLEN SCREW 3/16" X 3/16"
98	2	JRS2.5	RUBBER STOP 2 1/2" L (3/8" BOLT)
99	4	JJN.37	JAM NUT 3/8"
100	1	JCES.5X.75	CABLE END SHAFT 1/2" X 3/4"
101	1	JAB.125X.31	ALLEN BOLT 1/8" X 5/16"
102	1	JAB.37X.875FTB	ALLEN BOLT 3/8" X 7/8" FULL THREAD
103	1	JSRTB.5X2FTB	SELECTOR ROD TOP BOLT 1/2" X 2" FULL THREAD
104	1	JJN.5	JAM NUT 1/2"
105	1	JSLW.5	SPRING LOCK WASHER 1/2"
106	2	JFPP4.75	FLAT POP PIN 4 3/4" L
107	2	JFG1.5X26	FOAM GRIP 1 1/2"OD X 26"L (pec dec handle)
108	1	JACN.19	ACORN CAP NUT 3/16" I.D. pre-installed
109	1	JHSA	HYDRAULIC SEAT ADJUSTER pre-installed
110	2	JFG1.5X8.5	FOAM GRIP 1 1/2"OD X 8.5"L (low row bar)
112	2	JFG1.5X18	FOAM GRIP 1 1/2"OD X 18"L (lat bar)
113	1	JLBP	LAT BAR PAD
115	2	JFG1.5X14	FOAM GRIP 1 1/2"OD X 14"L (seated press)
116	1	JNB2X2X6	NYLON BUSHING 2" X 2" X 6"L
120	2	JSB.75X1.37	STEEL BUSHING 3/4"ID X 1 3/8"OD -top frame (E)
121	4	JBB.62X1	OILITE BUSHING 5/8"ID X 1"OD -pulley swivel (AC)
122	8	JBB1X1.75	OILITE BUSHING 1"ID X 1 3/4"OD -pec arm cams and pec dec arms
123	4	JBB1X1.75	OILITE BUSHING 1"ID X 1 3/4"OD -pec arms and pec handles
124	2	JBB.5X.87	OILITE BUSHING 1/2"ID X 7/8"OD -back pad adjuster
125	2	JSB1X1.37	STEEL BUSHING 1"ID X 1 3/8"OD -seated press arm support (H)
126	4	JBB1X1.75	OILITE BUSHING 1"ID X 1 3/4"OD -top of seated press arms (L)(M)
127	4	JBB.5X1.87	OILITE BUSHING 1/2"ID X 1 7/8"OD -left&right arm pivot (LA)(MA)
128	4	JBB.37X.87	OILITE BUSHING 3/8"ID X 7/8"OD -left&right pivot (JG)(JH)
129	2	JBB.75X1	OILITE BUSHING 3/4"ID X 1"OD -left&right junction (JE)(JF)
130	2	JBB1X1.5	OILITE BUSHING 1"ID X 1 1/2"OD -left&right junction-inside (JE)(JF)
131	2	JWW.75	WAVE WASHER 3/4"ID X 1"OD
132	2	JRR1.25X1.5	RETAINING RING 1 1/4"ID X 1 1/2"OD
133	2	JSB.5X1.25	SEALED BEARING 1/2"ID X 1 1/4"OD
134	1		SPRING LOCK WASHER
150	1	JHEX.5X4.5PTB	HEX HEAD BOLT 1/2" X 4 1/2" PARTIAL THREAD
151	1	JLB	L-BRACKET
152	1	JLDH	LOCK DOWN HOOK
153	1	JS.31	SPACER 5/16" WIDE
154	1	JS.25	SPACER 1/4" WIDE
155	3	JPS1.75	PLASTIC STOP 1 3/4" L (3/8" BOLT)
156	2	JAH.31X.75FTB	ALLEN HEAD BOLT 5/16" X 5/8" FULLY THREAD
157	1	JBC.5	BOLT CAP 1/2"
158	1	JBCW.5	BOLT CAP WASHER 1/2"

**Part numbers are required when ordering parts.**

## Cable List

<b>KEY#</b>	<b>QTY</b>	<b>PART#</b>	<b>DESCRIPTION</b>
85	1	JHPC5060	HIGH PULLEY CABLE 5060mm 16' 7"
86	1	JLPC5150	LOW PULLEY CABLE 5150mm 16' 10"
87	1	JSC747	SHORT CABLE 747mm 2' 5"
88	1	JPDC2025	PEC DEC CABLE 2025mm 6' 7"

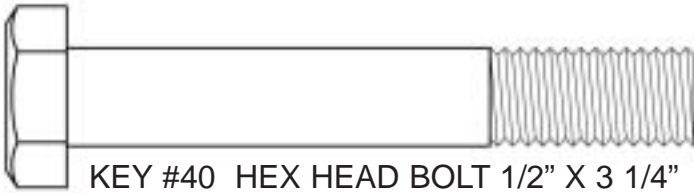
## Accessories List

<b>KEY#</b>	<b>QTY</b>	<b>PART#</b>	<b>DESCRIPTION</b>
24	1	G6BAS	ANKLE STRAP
25	1	G6BACH	AB-CRUNCH HARNESS
91	1	G6BWBB	WATER BOTTLE BRACKET
92	1	G6WBBS	WATER BOTTLE SCREWS
93	1	G6WBH	WATER BOTTLE HOLDER
111	1	G6BLRB	LOW ROW BAR
114	1	G6BLB	LAT BAR

**Part numbers are required when ordering parts.**

# G 6 B H A R D W A R E

( s h o w n i n a c t u a l s i z e )



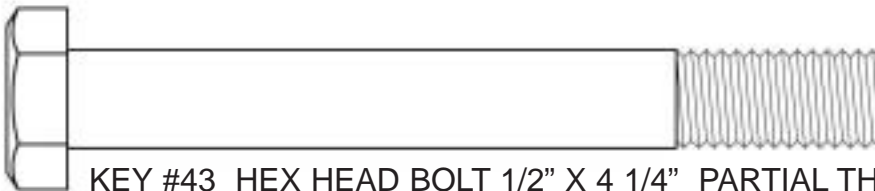
KEY #40 HEX HEAD BOLT 1/2" X 3 1/4" PARTIAL THREAD QTY. 12



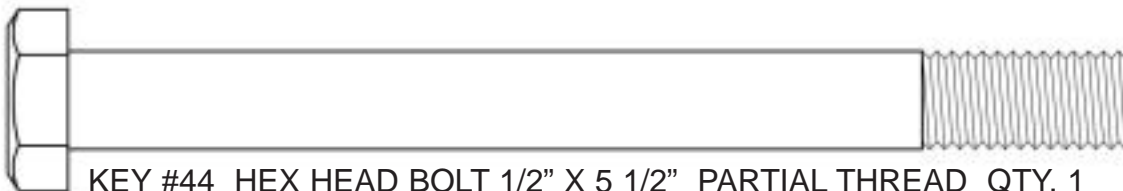
KEY #41 HEX HEAD BOLT 1/2" X 3 1/2" PARTIAL THREAD QTY. 1



KEY #42 HEX HEAD BOLT 1/2" X 3 3/4" PARTIAL THREAD QTY. 3



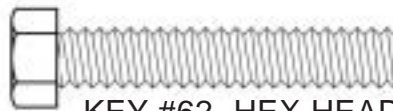
KEY #43 HEX HEAD BOLT 1/2" X 4 1/4" PARTIAL THREAD QTY. 2



KEY #44 HEX HEAD BOLT 1/2" X 5 1/2" PARTIAL THREAD QTY. 1



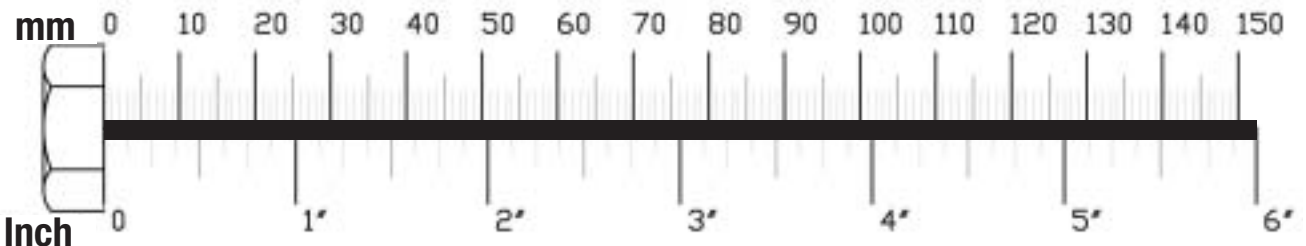
KEY #60 HEX HEAD BOLT  
5/16" X 1 1/2" FULL THREAD  
QTY. 2



KEY #62 HEX HEAD BOLT  
5/16" X 1 3/4" FULL THREAD  
QTY. 2

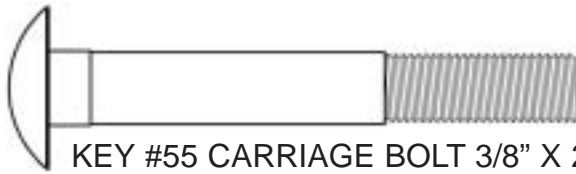


KEY #61 ALLEN HEAD BOLT 5/16" X 3/4" FULL THREAD QTY. 4

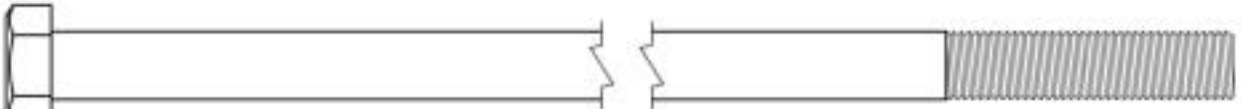


# G 6 B H A R D W A R E

( s h o w n i n a c t u a l s i z e )



KEY #55 CARRIAGE BOLT 3/8" X 2 3/4" PARTIAL THREAD QTY. 2



KEY #54 HEX HEAD BOLT 3/8" X 7 1/4" PARTIAL THREAD QTY. 2



KEY #56 HEX HEAD BOLT 3/8" X 3 1/4" PARTIAL THREAD QTY. 2



KEY #53 HEX HEAD BOLT 3/8" X 3" PARTIAL THREAD QTY. 7



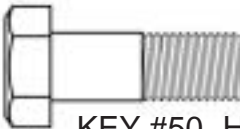
KEY #52 HEX HEAD BOLT 3/8" X 2 3/4" PARTIAL THREAD QTY. 4



KEY #57 HEX HEAD BOLT 3/8" X 2 1/2" PARTIAL THREAD QTY. 1



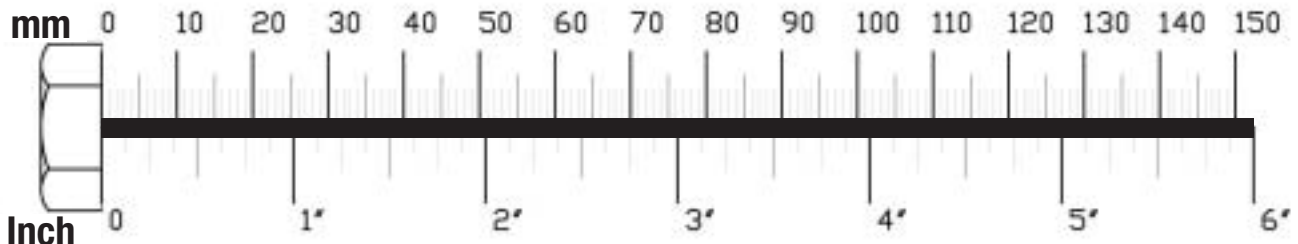
KEY #51 HEX HEAD BOLT 3/8" X 1 3/4" PARTIAL THREAD QTY. 22



KEY #50 HEX HEAD BOLT 3/8" X 1" PARTIAL THREAD QTY. 8

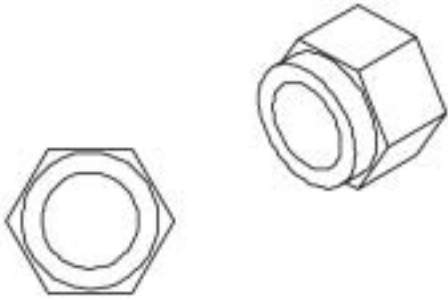


KEY #58 SOCKET HEAD BOLT 3/8" X 2" FULL THREAD QTY. 1

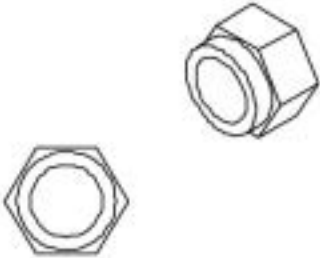


# G 6 B H A R D W A R E

( s h o w n i n a c t u a l s i z e )



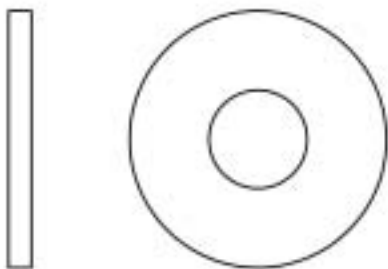
KEY #70 NYLON LOCK NUT 1/2"  
QTY. 9



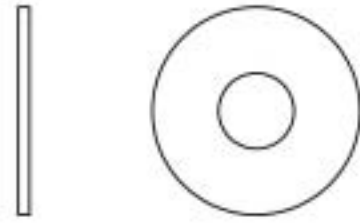
KEY #71 NYLON LOCK NUT 3/8"  
QTY. 46



KEY #78 WASHER 3/8" X 3/4"  
QTY. 10



KEY #73 WASHER 1/2" QTY. 73



KEY #74 WASHER 3/8" QTY. 48



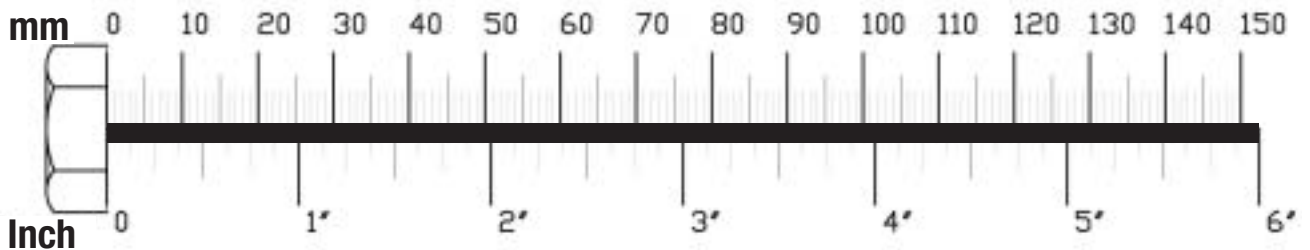
KEY #75 SPRING LOCK WASHER  
3/8" QTY. 2



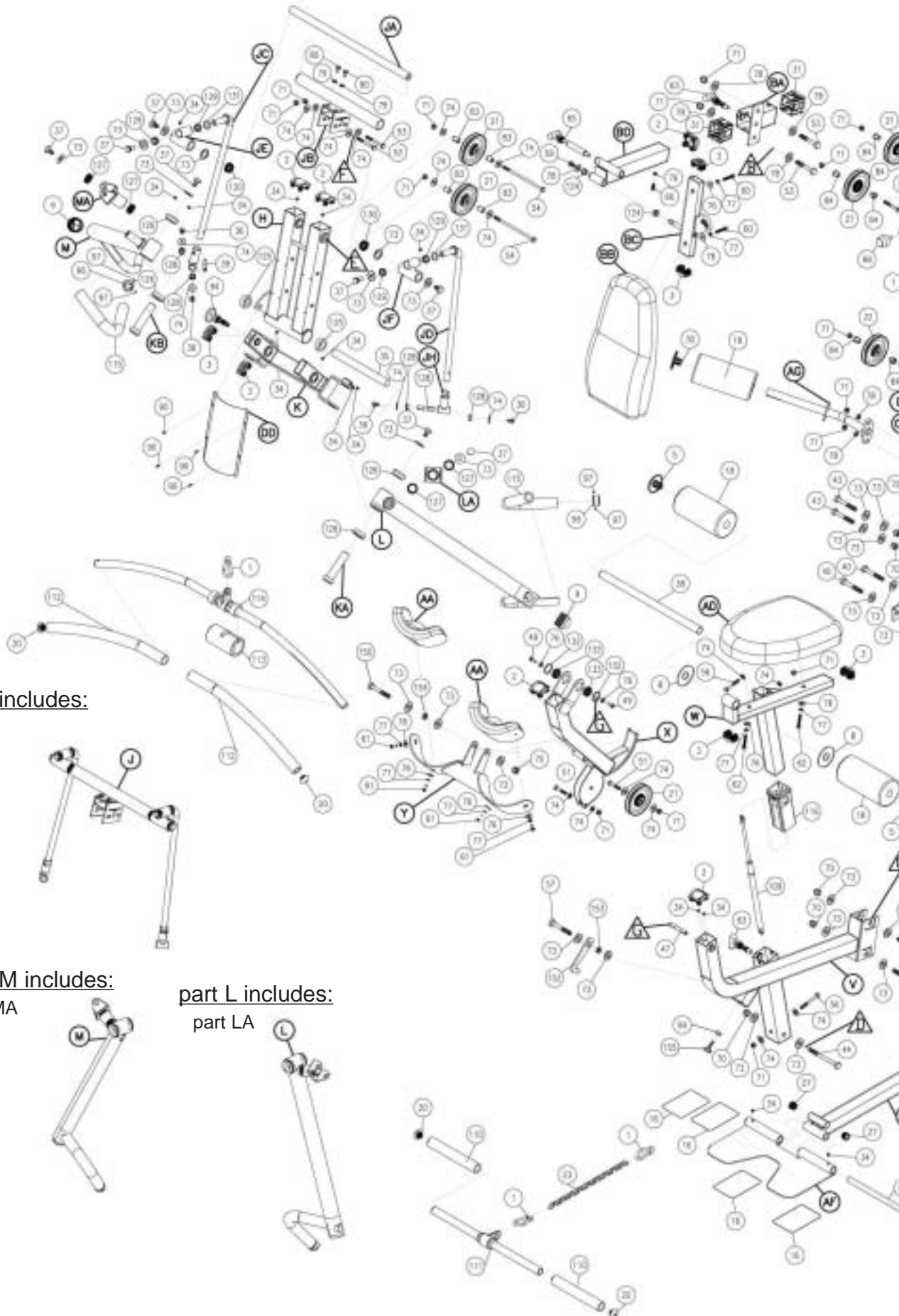
KEY #77 SPRING LOCK WASHER  
5/16" QTY. 8



KEY #76 WASHER 5/16" QTY. 8







part J includes:

- part JA
- part JB
- part JC
- part JD
- part JE
- part JF
- part JG
- part JH



part M includes:

- part MA



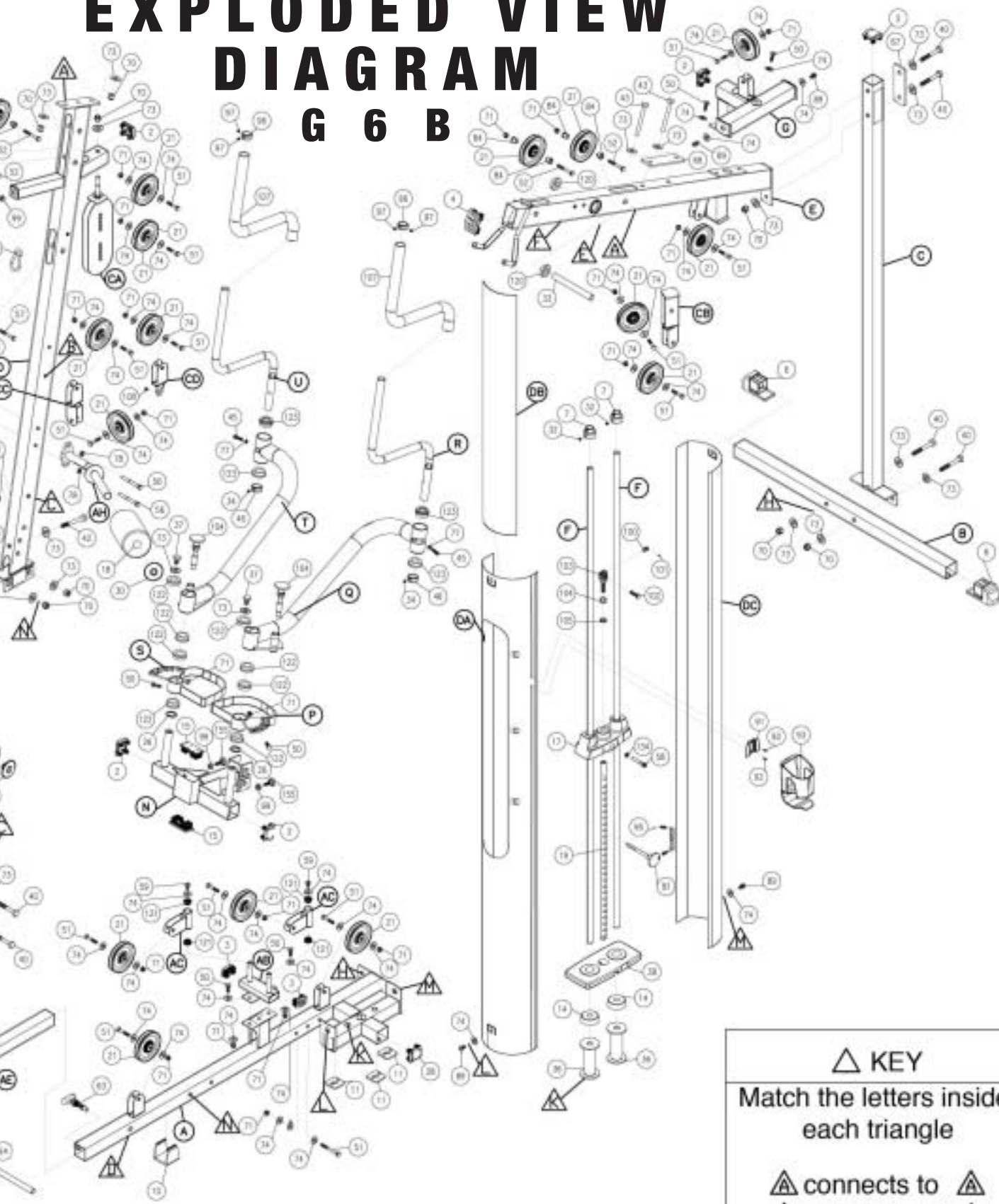
part L includes:

- part LA



# EXPLODED VIEW DIAGRAM

**G 6 B**



**△ KEY**

Match the letters inside each triangle

△ connects to	△
△ connects to	△
△ connects to	△