

Body-Solid

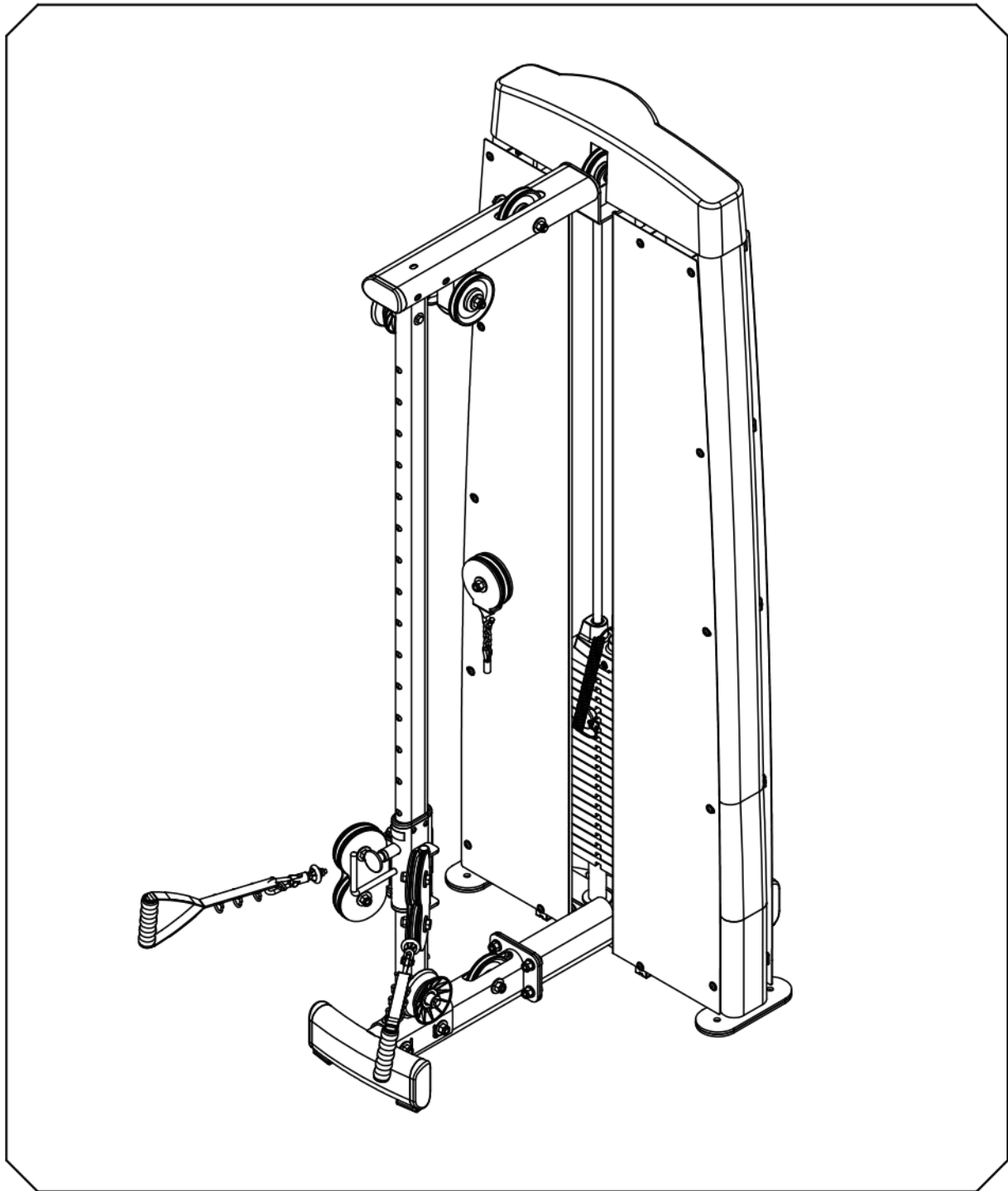

Sport-Thieme GmbH
Helmstedter Straße 40
38368 Grasleben
Telefon: +49 (0) 5357 181-81
Fax: +49 (0) 5357 181 90
info@sport-thieme.de
www.sport-thieme.de

DPCC.2 OWNER'S MANUAL

DPCC ASSEMBLY INSTRUCTIONS

HARDWARW ILLUSTRATION

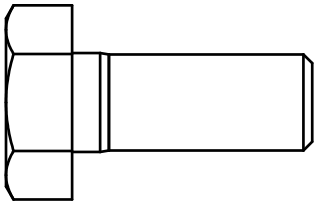

(A1)HEX BOLT 1/2"X1-1/4"L PARTIAL QTY.4

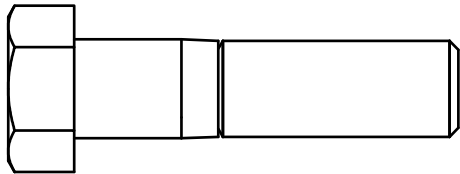

(A2)HEX BOLT 1/2"X2"L PARTIAL QTY.4

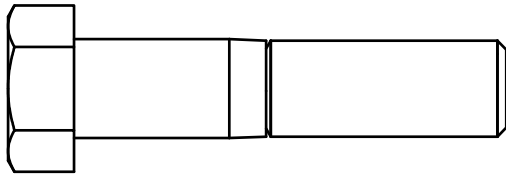

(A3)HEX BOLT 1/2"X2-1/4"L PARTIAL QTY.1

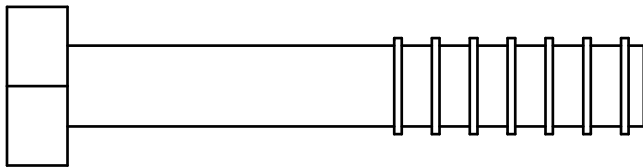

(A4)HEX BOLT 1/2"X3"L PARTIAL QTY.1

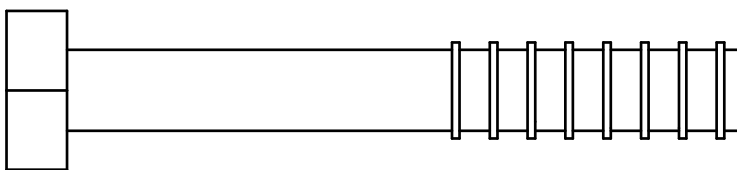

(A5)HEX BOLT 1/2"X3-1/2"L PARTIAL QTY.2

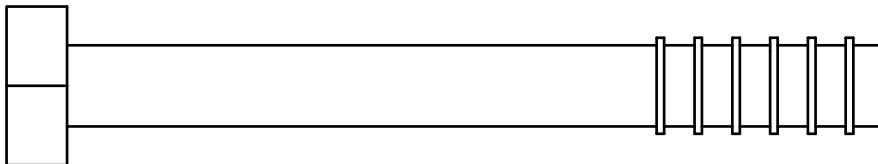

(A6)HEX BOLT 1/2"X4-1/4"L PARTIAL QTY.2

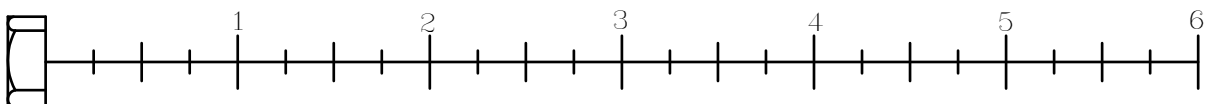

DPCC ASSEMBLY INSTRUCTIONS

HARDWARE ILLUSTRATION

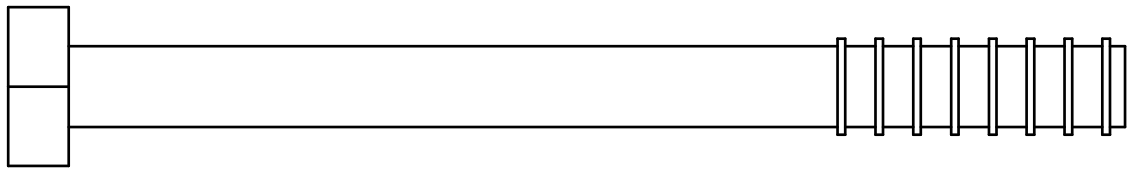

(A7)HEX BOLT 1/2"X5-1/2"L PARTIAL QTY.1

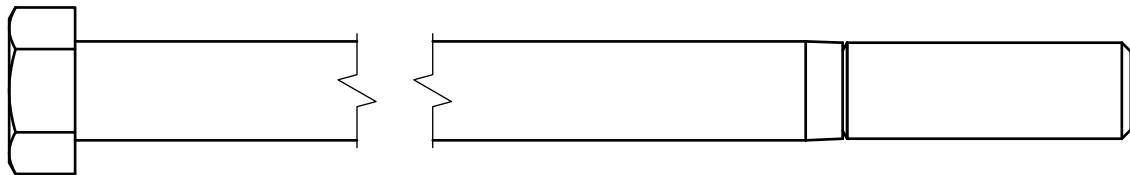

(A8)HEX BOLT 1/2"X6-1/2"L PARTIAL QTY.2

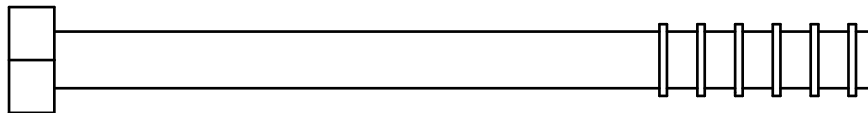

(A9)HEX BOLT 3/8"X4-1/4"L PARTIAL QTY.1

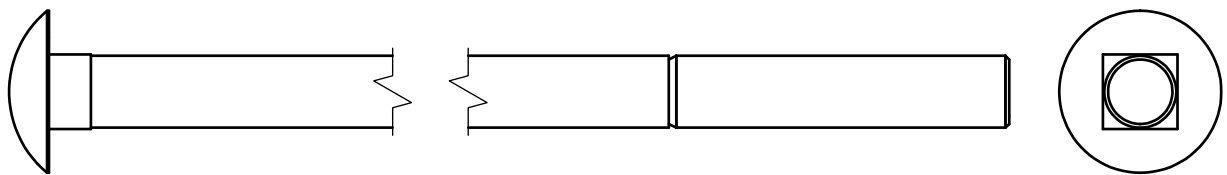

(A10)ROUND ALLEN HEAD 3/8"X5"-1/4"L PARTIAL QTY.2

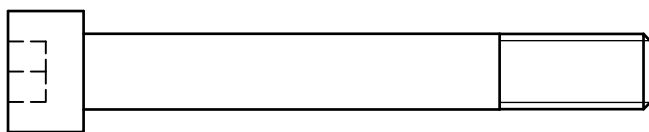

(A11)ROUND ALLEN HEAD M10X75L PARTIAL THREAD QTY.2

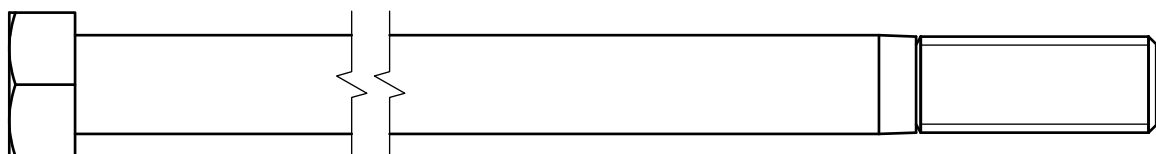

(A12)HEX BOLT 1/2"X6-1/4"L PARTIAL QTY.1

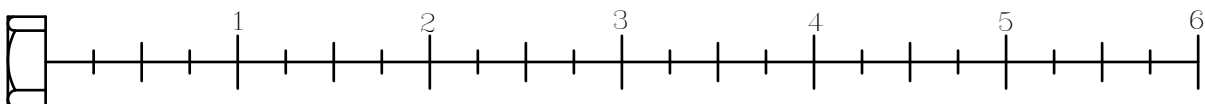

DPCC ASSEMBLY INSTRUCTIONS

HARDWARW ILLUSTRATION

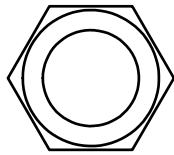
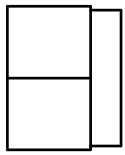

(B1) NYLON LOCK NUT 1/2" QTY. 18

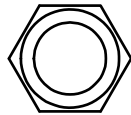
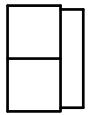

(B2) NYLON LOCK NUT 3/8" QTY. 3

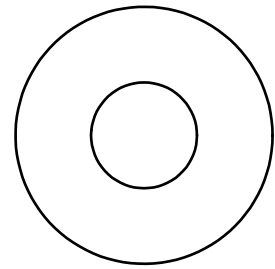

(C1) 1/2" (I.D.) FLAT WASHER Ø34 QTY. 24

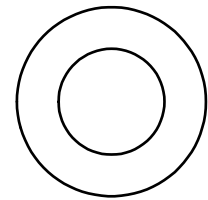

(C2) 1/2" (I.D.) FLAT WASHER Ø25 QTY. 12

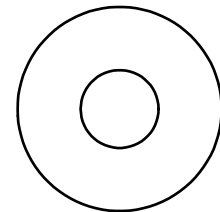
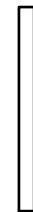

(C3) 3/8" (I.D.) FLAT WASHER Ø27 QTY. 4

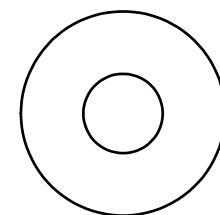

(C4) M10 (I.D.) FLAT WASHER Ø27 QTY. 2

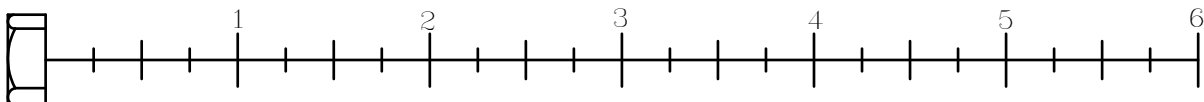

DPCC ASSEMBLY INSTRUCTIONS

HARDWARW ILLUSTRATION

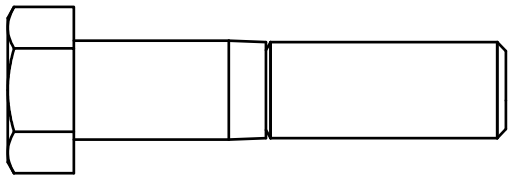

(AA2)HEX BOLT 1/2"X2-1/4"L PARTIAL QTY.1

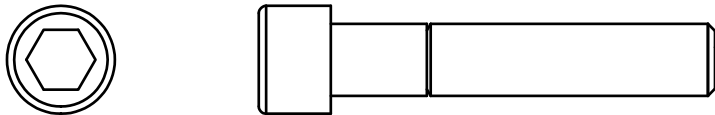

(AA4)ROUND INNER HEAD 3/8"X2"L PARTIAL QTY.1



(AA5)ROUND INNER HEX SCREW M6X20L PARTIAL QTY.24



(AA6)ROUND CROSS SCREW 5/32"X1/4"L PARTIAL QTY.4

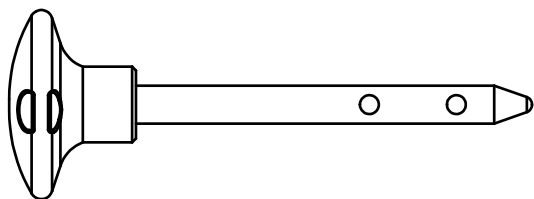

(AA7)10LB PIN(8250-071) QTY.1

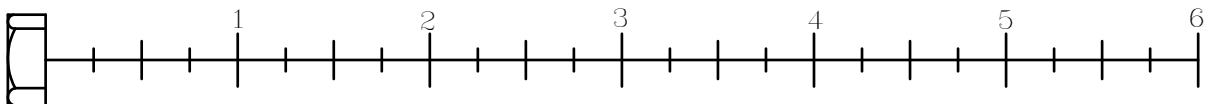

DPCC ASSEMBLY INSTRUCTIONS

HARDWARW ILLUSTRATION

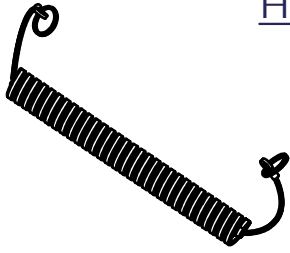

(AA8)ELASTIC BOLT QTY.1

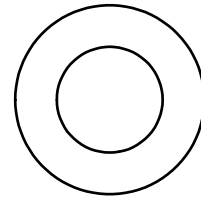

(CC1)1/2"(I.D.)FLAT WASHER Ø25 QTY.2

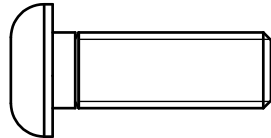
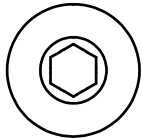

(AA10)ROUND INNER HEX SCREW
M10X30L PARTIAL QTY.1

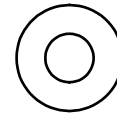

(CC2)M6(I.D.)FLAT WASHER Ø13 QTY.24

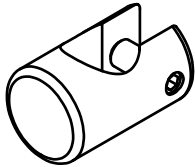

(AA11)FIRM SHEATH(8890-046) QTY.1

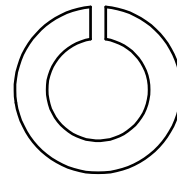

(CC4)SPRING WASHER 1/2" QTY.1

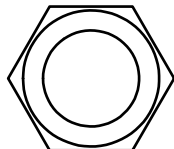
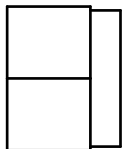

(BB2)NYLON LOCK NUT1/2" QTY.1

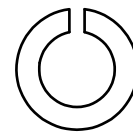

(CC5)SPRING WASHER 3/8" QTY.1

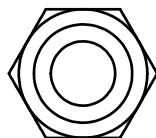
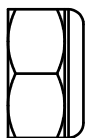

(BB3)NYLON LOCK NUT M10 QTY.1

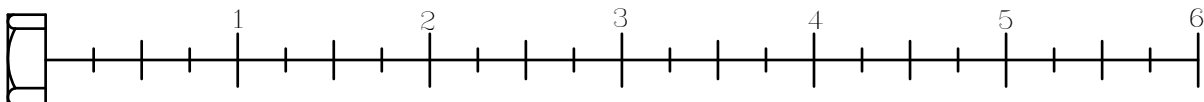

DPCC ASSEMBLY INSTRUCTIONS

HARDWARW ILLUSTRATION

	(D2)Ø3/4"X16L STEEL BUSHING(8110-066) -----	[4PCS]
	(D3)Ø3/4"X45L STEEL BUSHING(8110-067) -----	[2PCS]
	(D4)Ø8X80L SPRING SNAP LINK(8810-001) -----	[2PCS]
	(D5)Ø3/4"SHAFT COLLAR(9211-046) -----	[2PCS]
	(D6)□50X50X1.8t END CAP(9211-087) -----	[1PCS]
	(D7)50X100 NYLON BUSHING(9211-107) -----	[2PCS]
	(D8)58X116X2.5t FOOT CAP(9211-108) -----	[4PCS]
	(D9)58X116X2.5t END CAP(9211-112) -----	[1PCS]
	(D10)Ø4" PULLEY(9213-022A) -----	[2PCS]
	(D11)Ø4 1/2" PULLEY(9213-010B) -----	[10PCS]
	(D12)Ø2-1/2"RUBBER DOUNT(9310-010)-----	[2PCS]
	(D13)95X250 RUBBER PAD(9310-060) -----	[2PCS]
	(D14)HANDLE(9630-125) -----	[2PCS]
	(D15)TOP PLATE(8400-006) -----	[1PCS]
	(D17)6845mm STEEL CABLE(FDPCCA)-----	[1PCS]
	(D18)4160mm STEEL CABLE(FDPCCB) -----	[1PCS]
	(D19)DPCC FOR DGYM CABLE(FDPCCC)-----	[1PCS]
	(D20)WEIGHT SELECTOR BAR(8210-042B) -----	[1PCS]

D2



D3

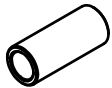

D4

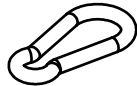

D5



D6

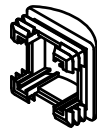

D7

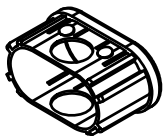

D8



D9



D10



D11

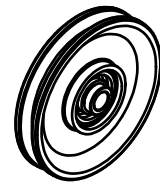

D12

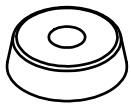

D13

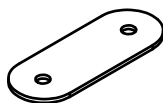

D14

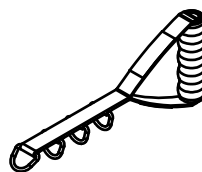

D15

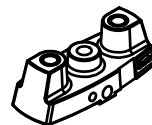

D17

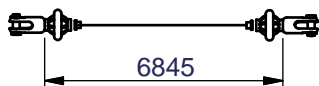

D18

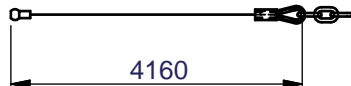

D19

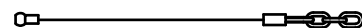

D20

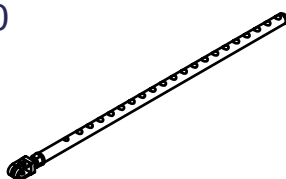

DPCC ASSEMBLY INSTRUCTIONS

PARTS ILLUSTRATION

A [1PCS]

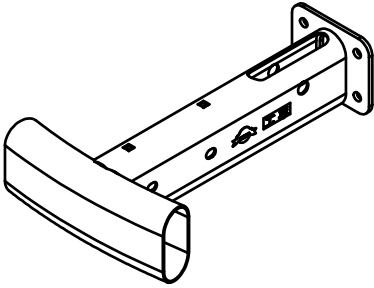

B [1PCS]

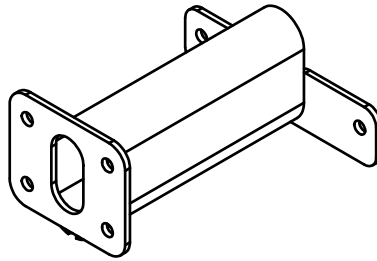

C [1PCS]

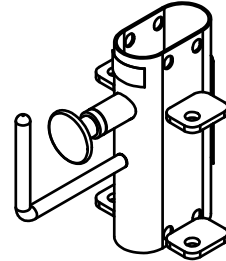

D [2PCS]

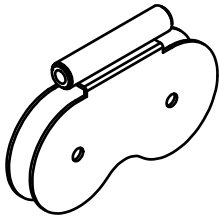

E [1PCS]

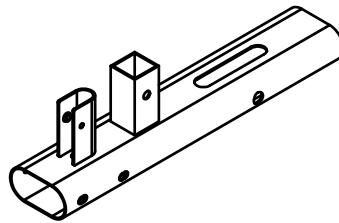

F [1PCS]

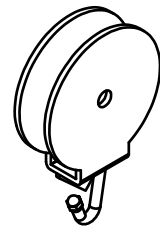

G [1PCS]

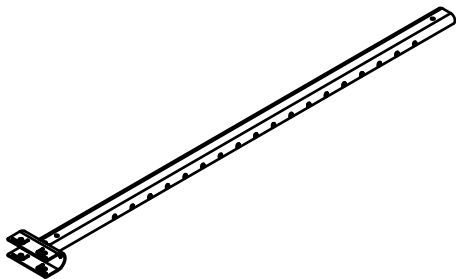

H [1PCS]

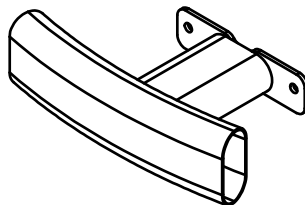

I [2PCS]

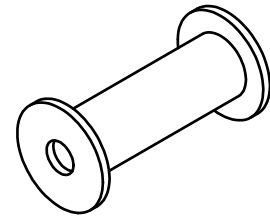

DPCC ASSEMBLY INSTRUCTIONS

PARTS ILLUSTRATION

AA[1PCS]
6610-001

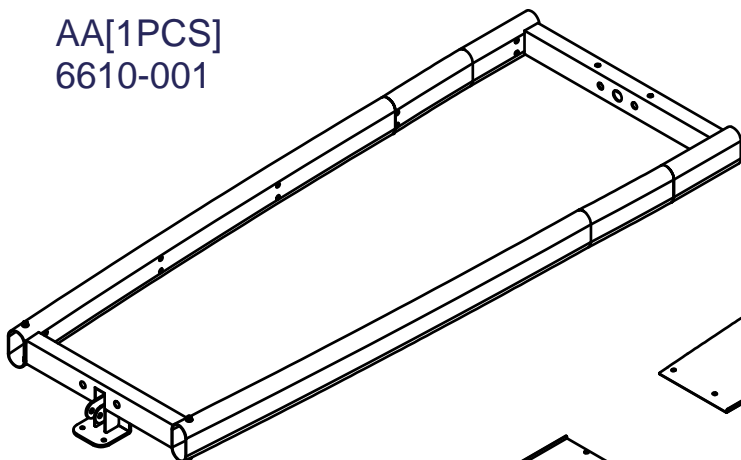

BB[1PCS]
8380-044

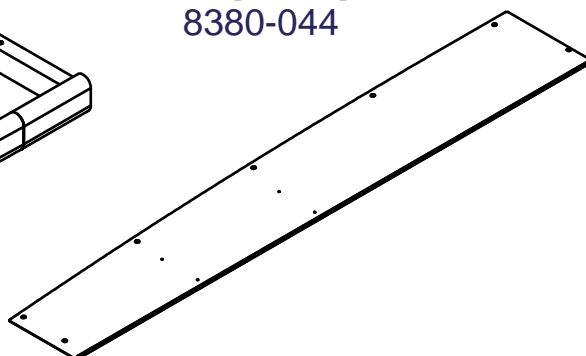

CC[1PCS]
8380-052

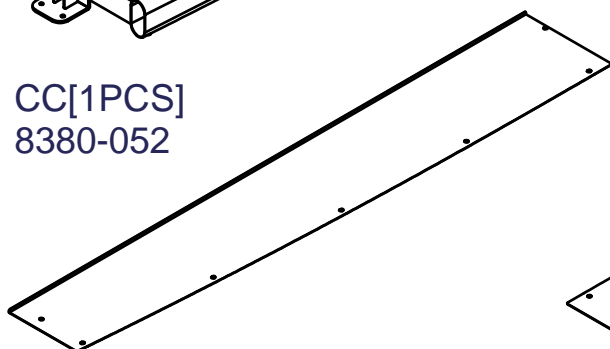

DD[1PCS]
8380-045

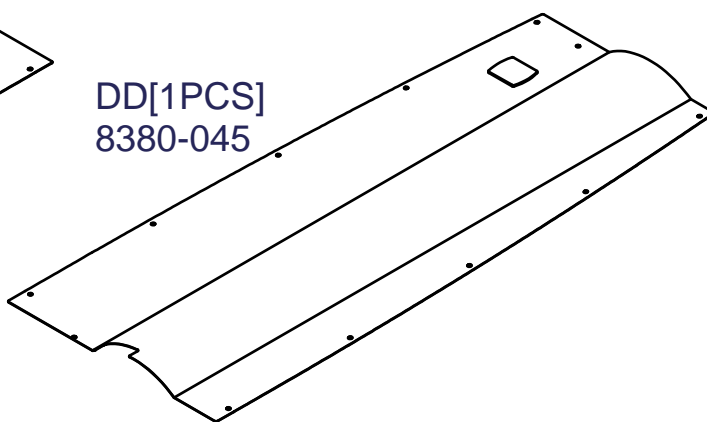

EE[2PCS]
Ø3/4"X1930L

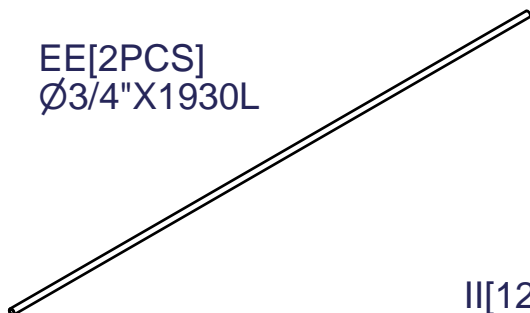

FF[1PCS]
9440-177

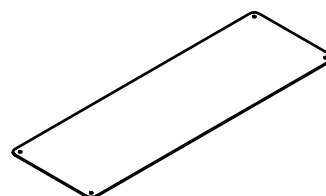

KK[1PCS]
9211-119A

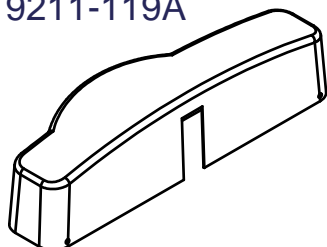

II[12PCS]
8321-040
both side

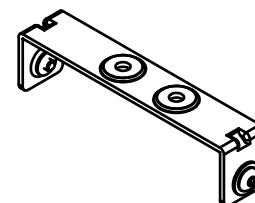
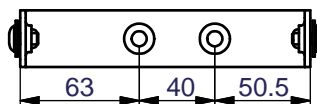

HH[2PCS]
8313-144

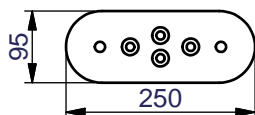

JJ[2PCS]
8321-040
one side

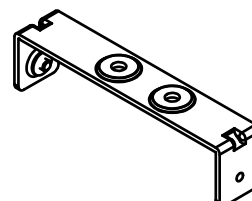
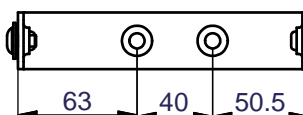

DPCC ASSEMBLY INSTRUCTIONS

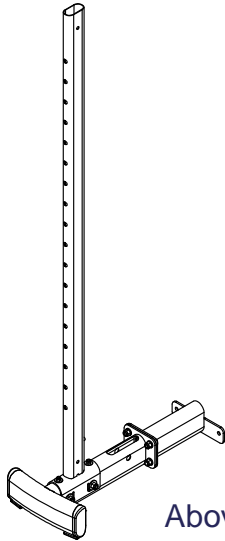

Above shows STEP1
assembled and completed

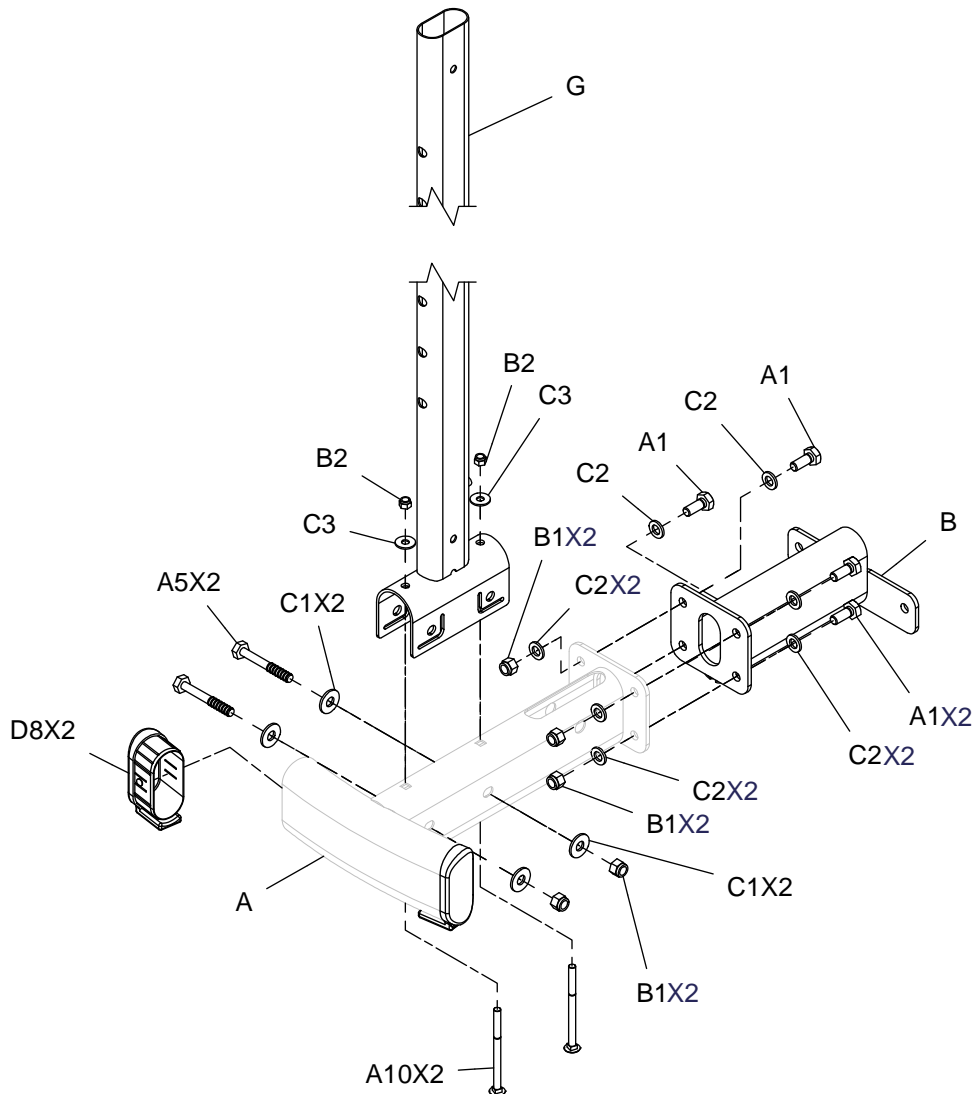

DPCC ASSEMBLY INSTRUCTIONS

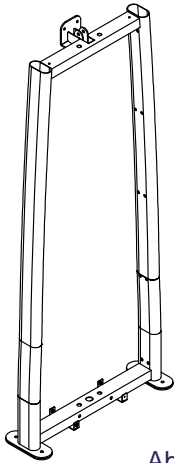

Above shows STEP 2
assembled and completed

DPCC single weight stack assembly instructions

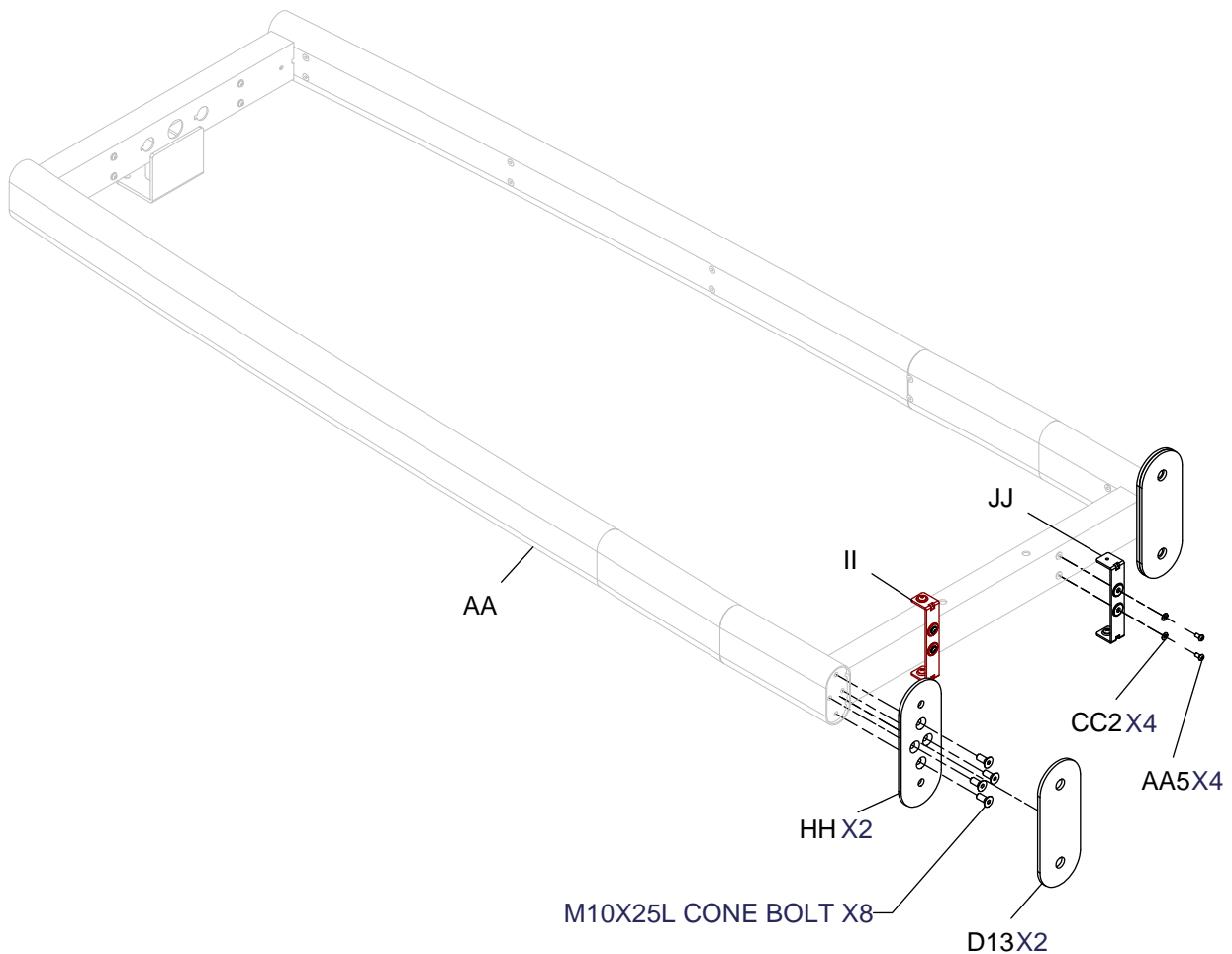

DPCC ASSEMBLY INSTRUCTIONS

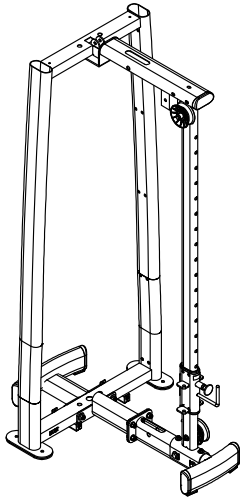

Above shows STEP 3
assembled and completed

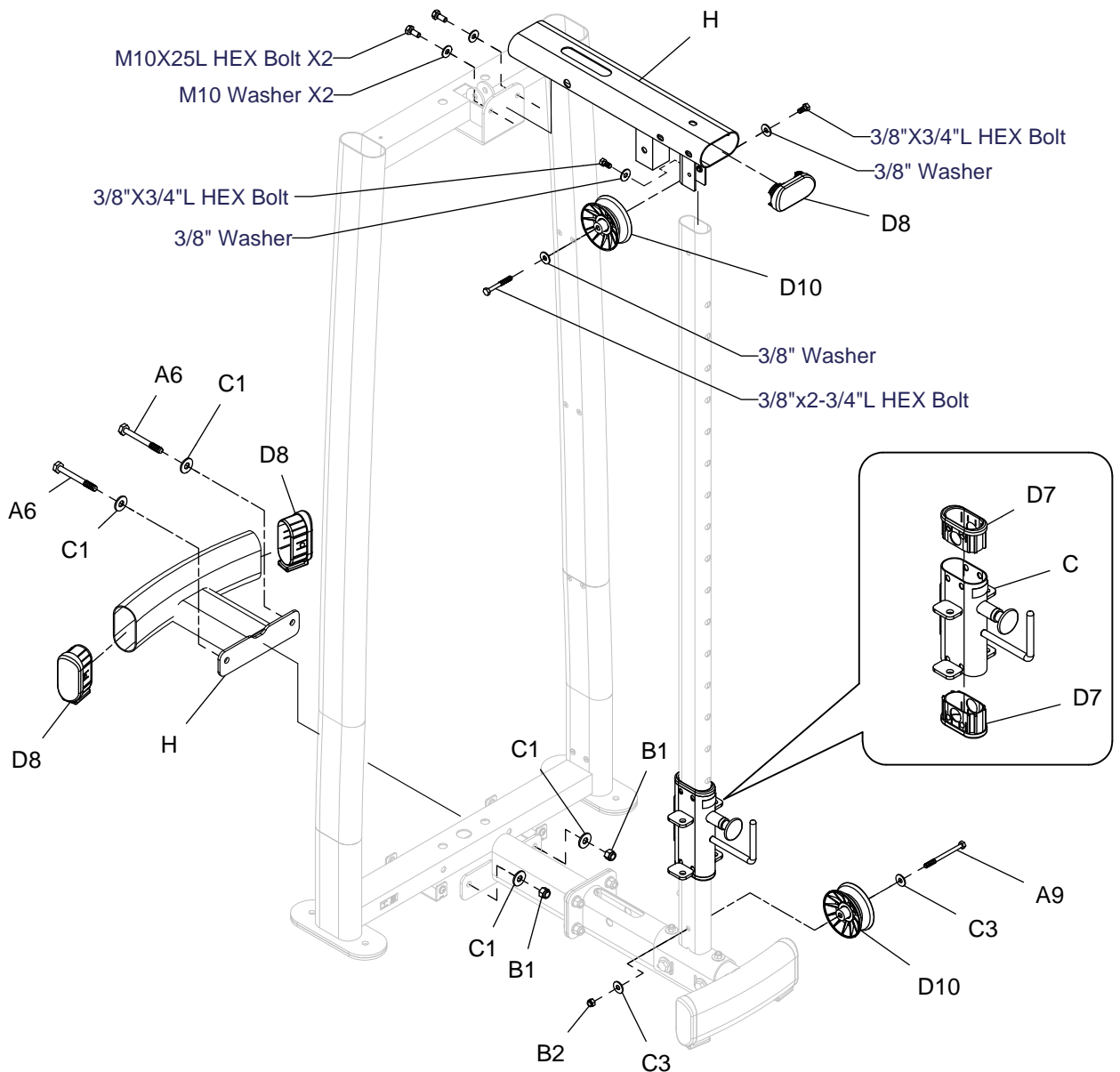

DPCC ASSEMBLY INSTRUCTIONS

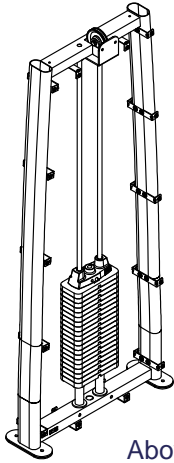

Above shows STEP 4 assembled and completed

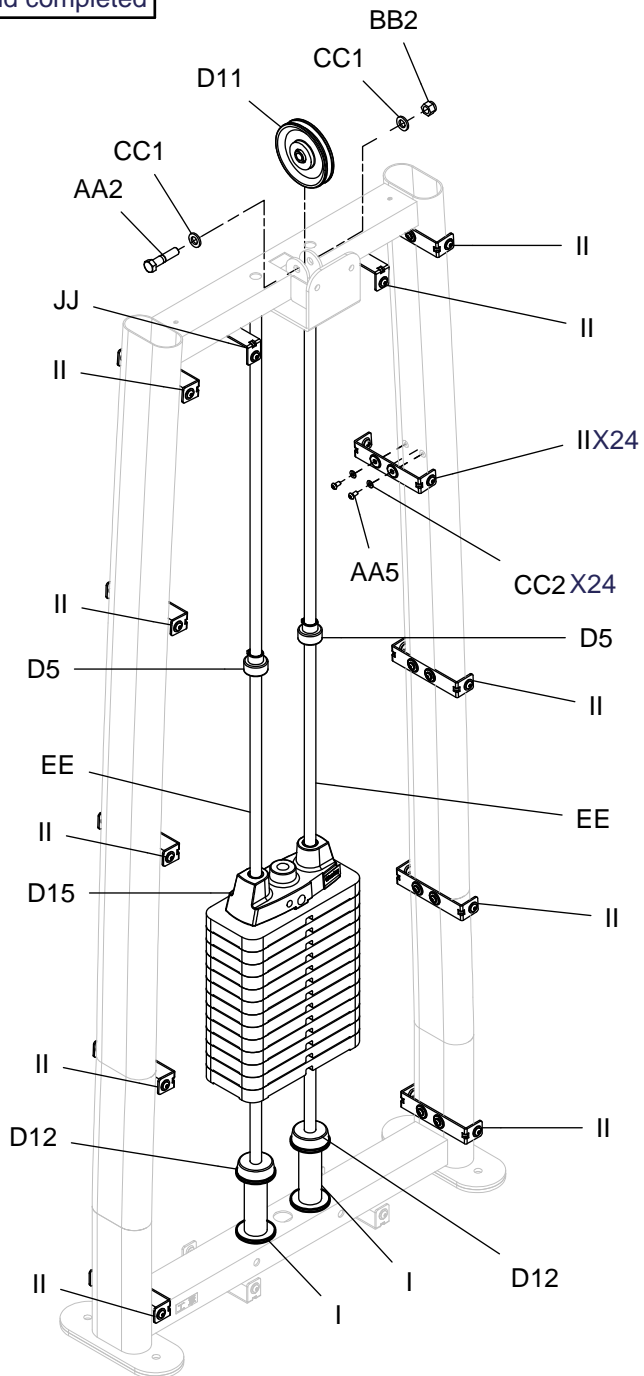

DPCC ASSEMBLY INSTRUCTIONS

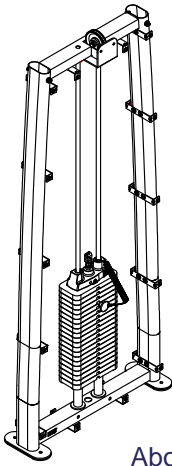

Above shows STEP 5
assembled and completed

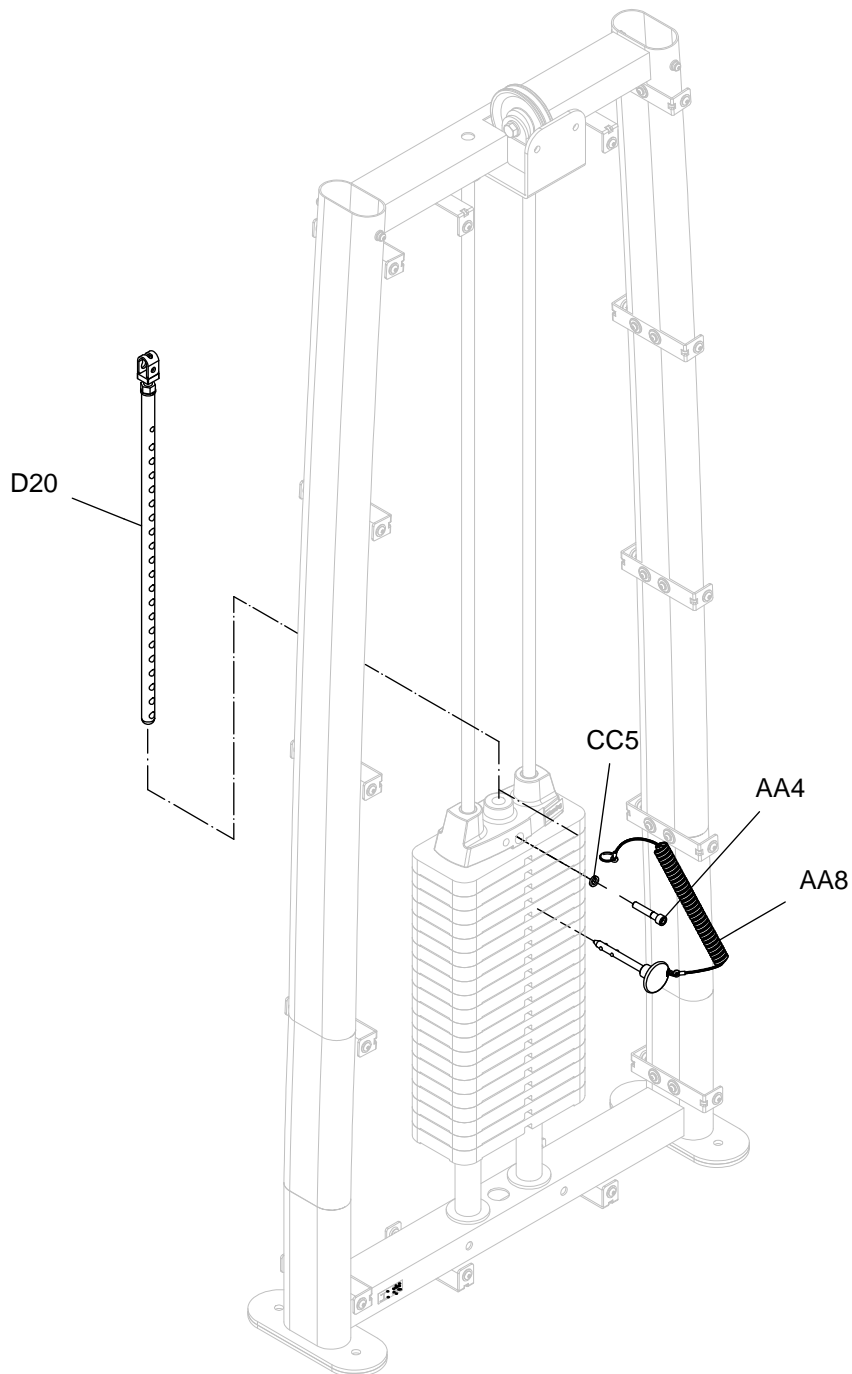

DPCC ASSEMBLY INSTRUCTIONS

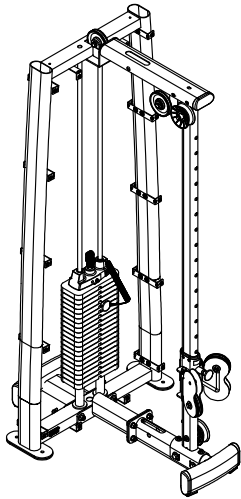

Above shows STEP 6 assembled and completed

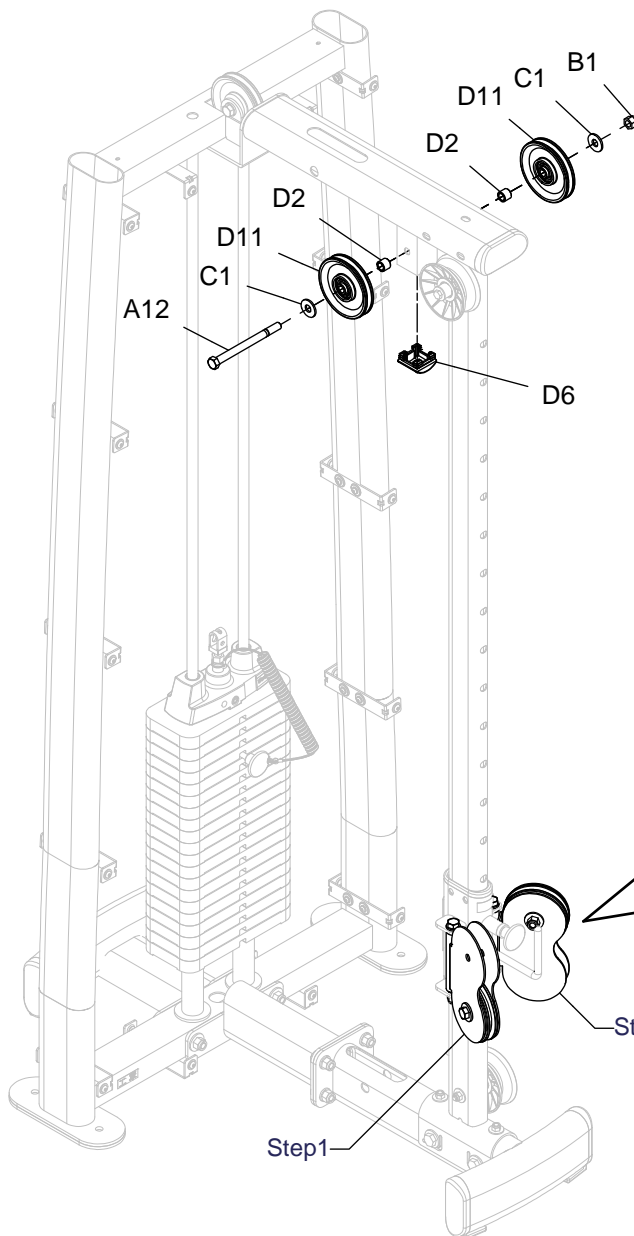

DETAIL VIEW

Step 1

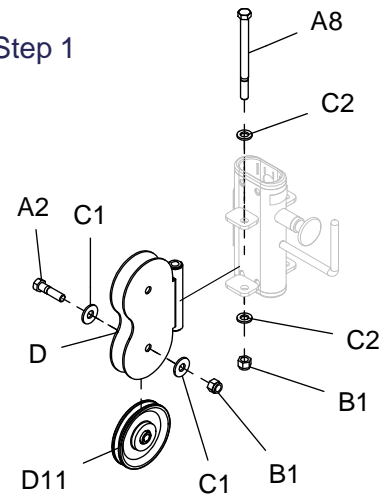

Step 2

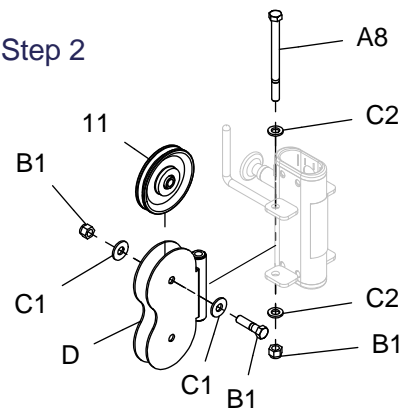

DPCC ASSEMBLY INSTRUCTIONS

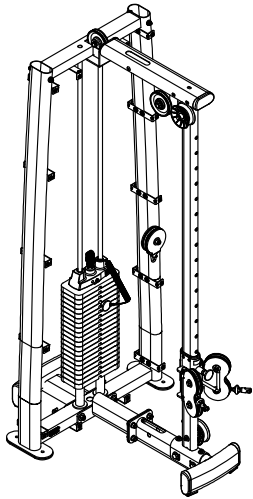

Above shows STEP 7
assembled and completed

D17.

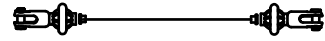

DETAIL VIEW

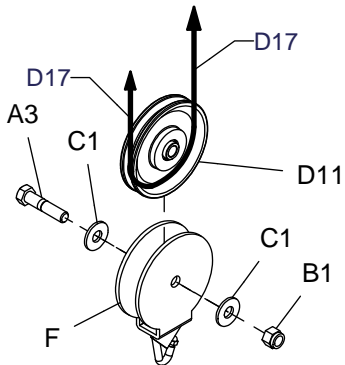

DETAIL VIEW

Step 1

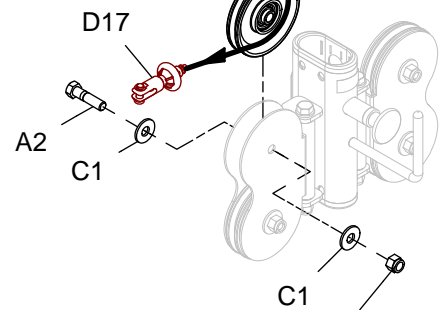

Step 2

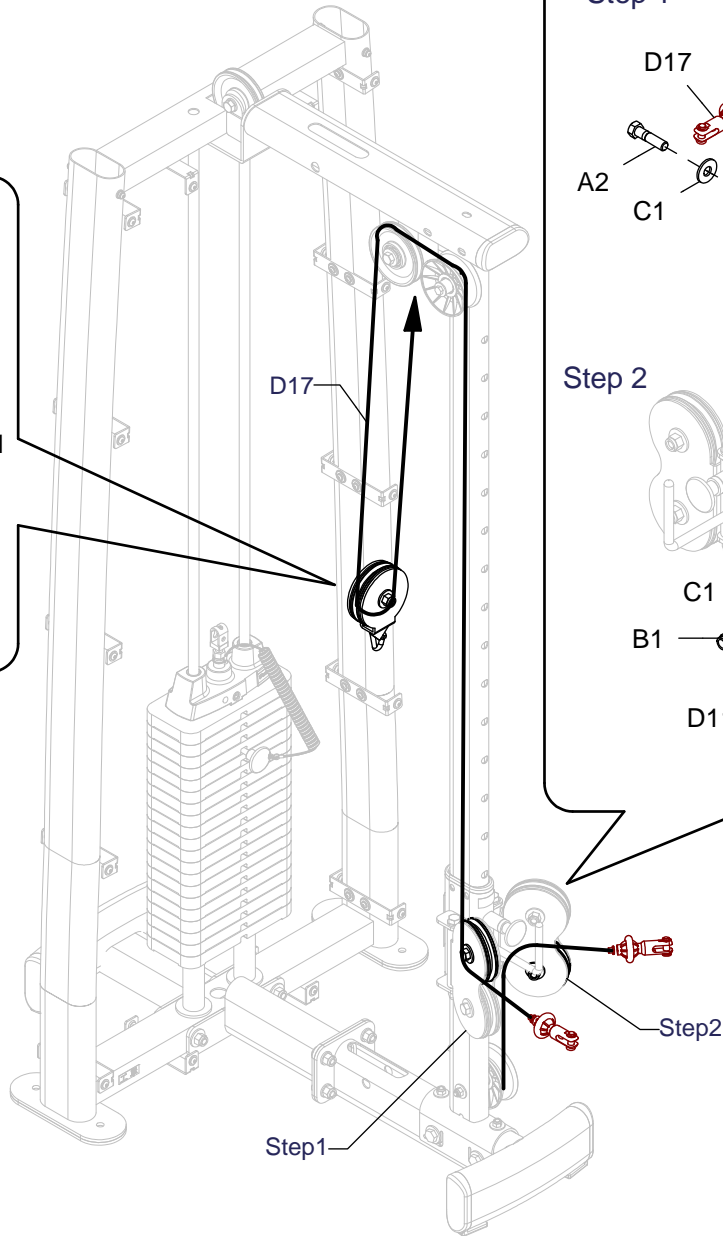
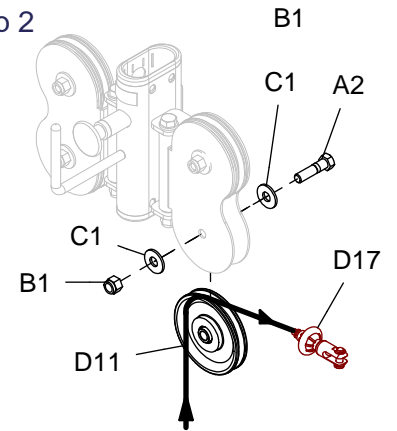

DPCC ASSEMBLY INSTRUCTIONS

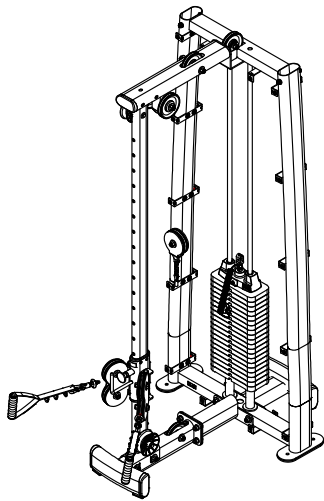

Above shows STEP 8
assembled and completed

D18.

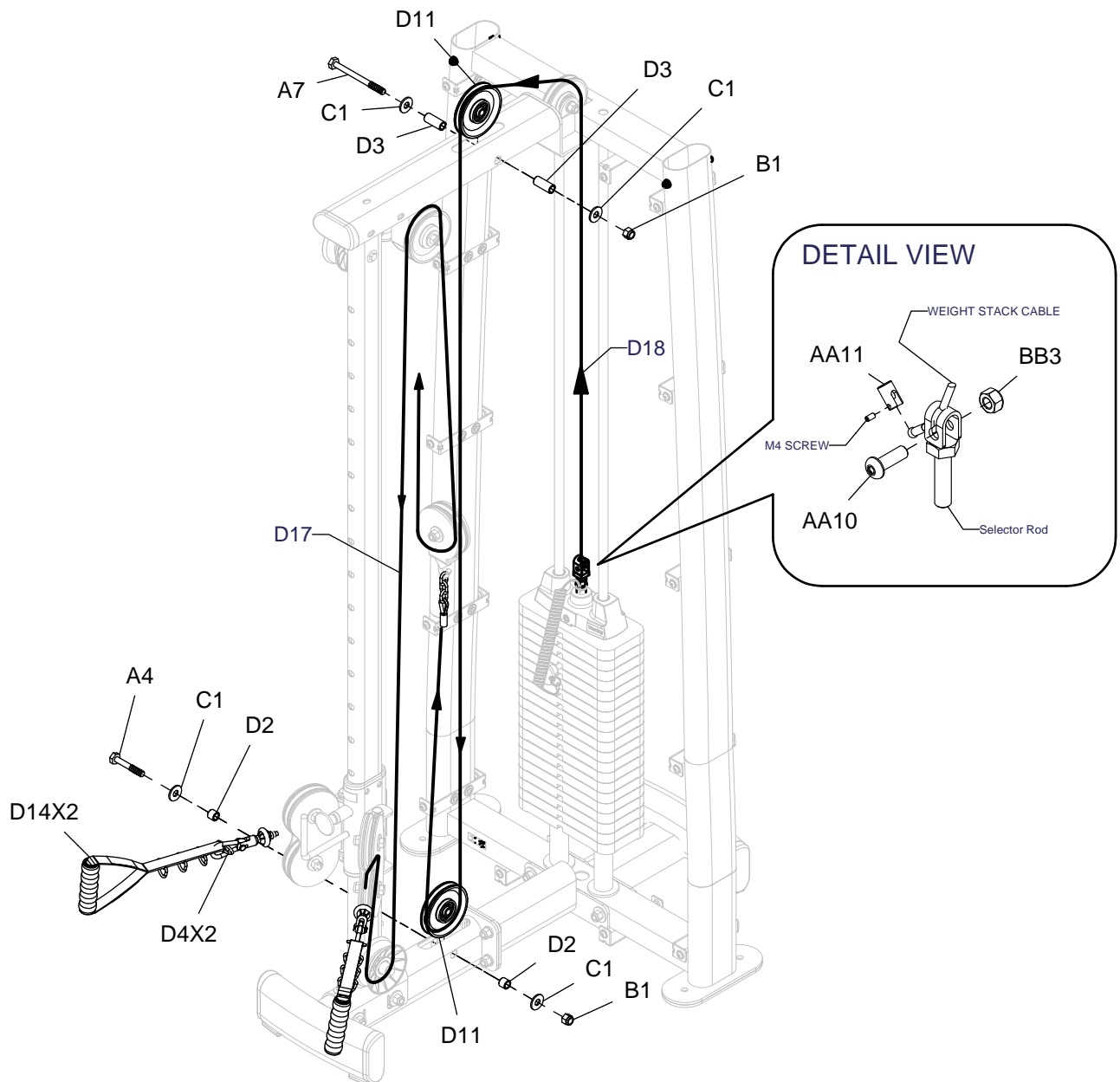
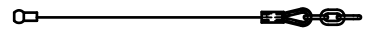

DETAIL VIEW

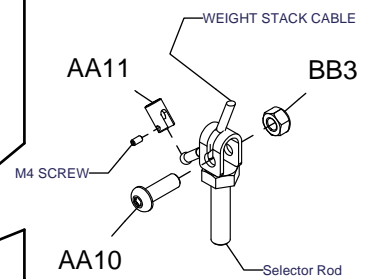

DPCC ASSEMBLY INSTRUCTIONS

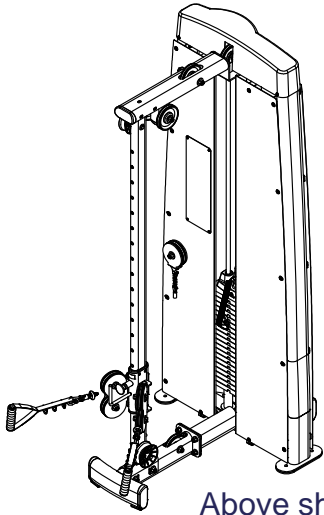

Above shows STEP 9
assembled and completed

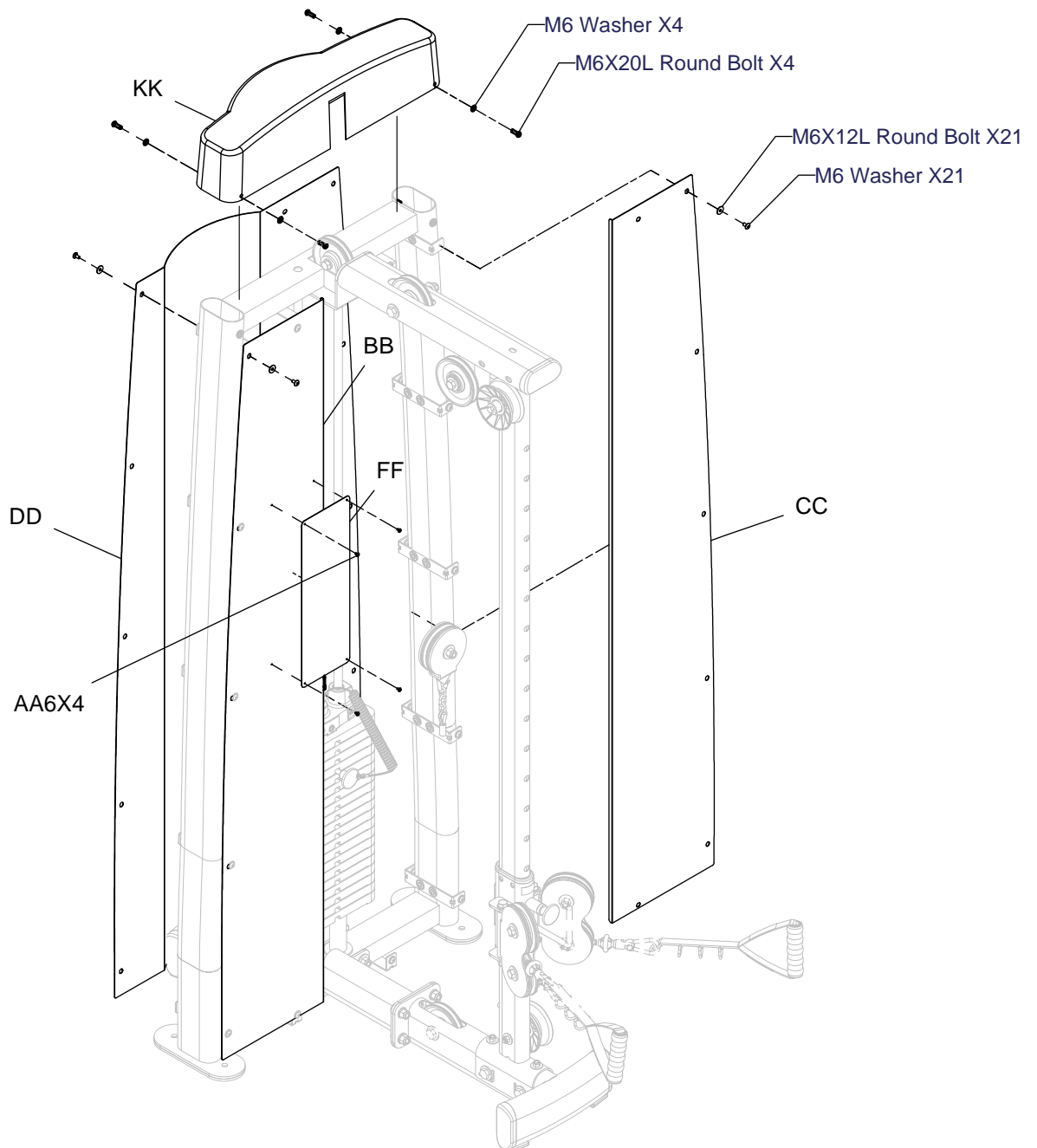

DPCC ASSEMBLY INSTRUCTIONS

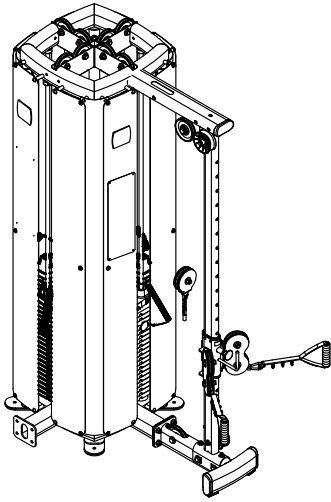

Above shows STEP 10 assembled and completed

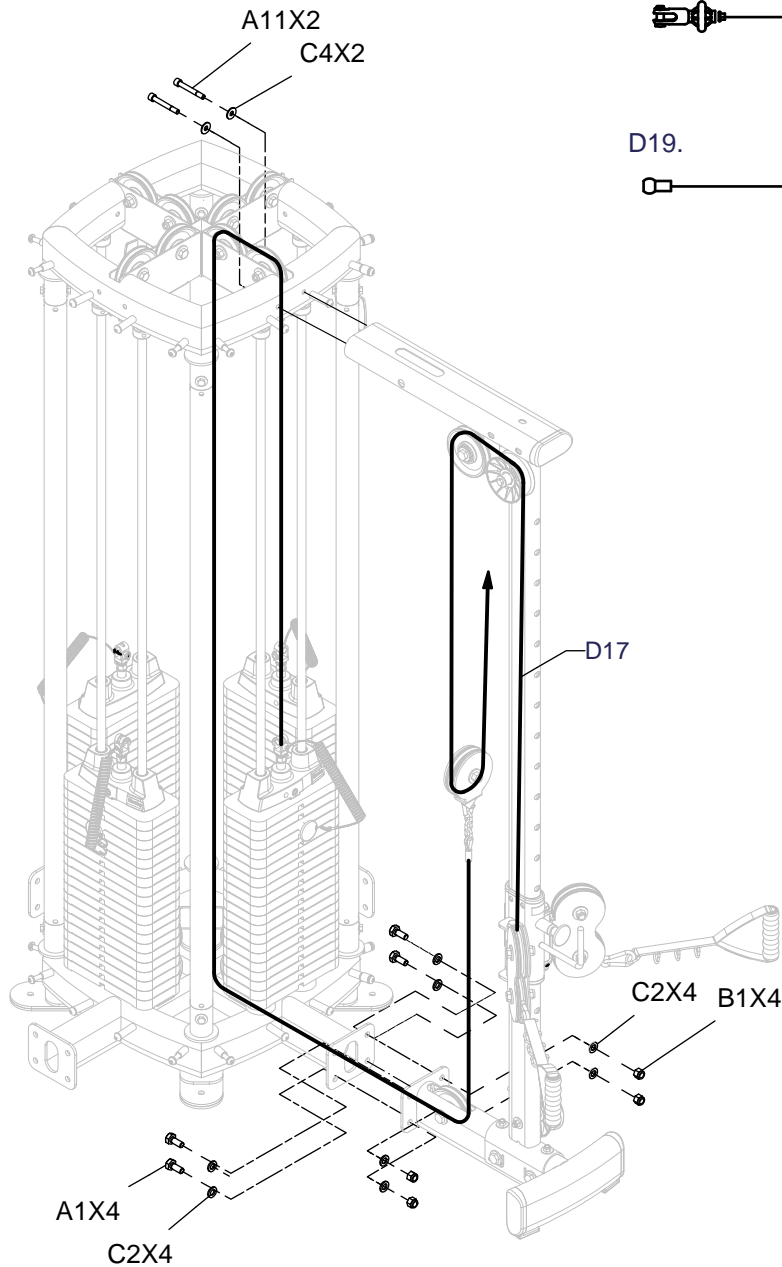

D17.

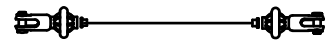

D19.



DPCC ASSEMBLY INSTRUCTIONS

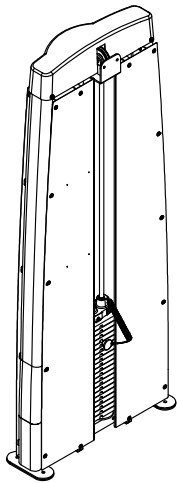
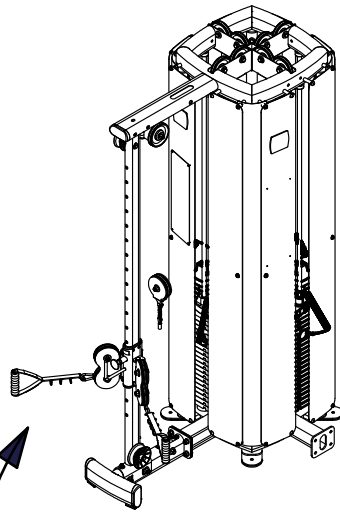
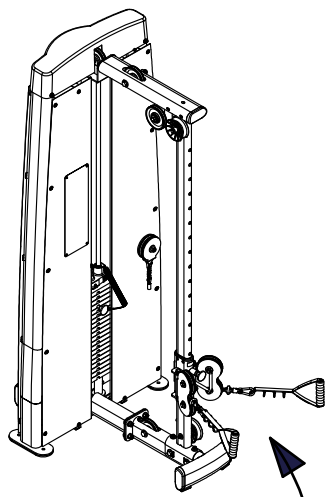

DFC

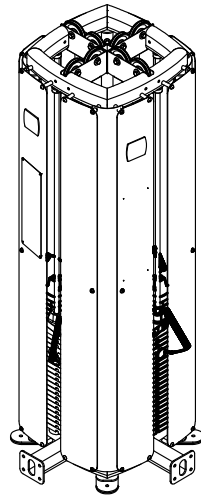

DGYM

[B]

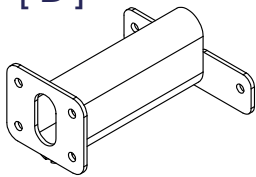

[A]

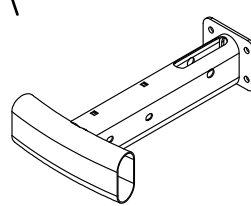

DPCC

