

PUZZLE MAT 3D - INSTALLATION GUIDE

Contents

<i>I. Installation steps</i>	1
<i>II. Installing the tiles</i>	2
<i>III. Special dimensions</i>	6
<i>IV. Maintenance</i>	7

I. Installation steps

1. Removal of the top layer of soil down to the hard subsoil
2. Creation of a base layer of gravel (20-40cm) with a grain size of 0-32mm or 0-45mm
3. Compacting the entire surface with a vibratory compactor (a uniform horizontal surface should be formed)
4. Create a 2-3cm thick water-permeable gravel/cement layer. The layer (0-8mm or 3-7mm grain size) should have a proportion of 7 to 1 with 60% less water than mixing cement. Use a measuring instrument and make the layer plane. When you strip the layer do not keep hills and indentations. Let the surface cure for 3-4 hours.
5. Laying with edge and corner elements

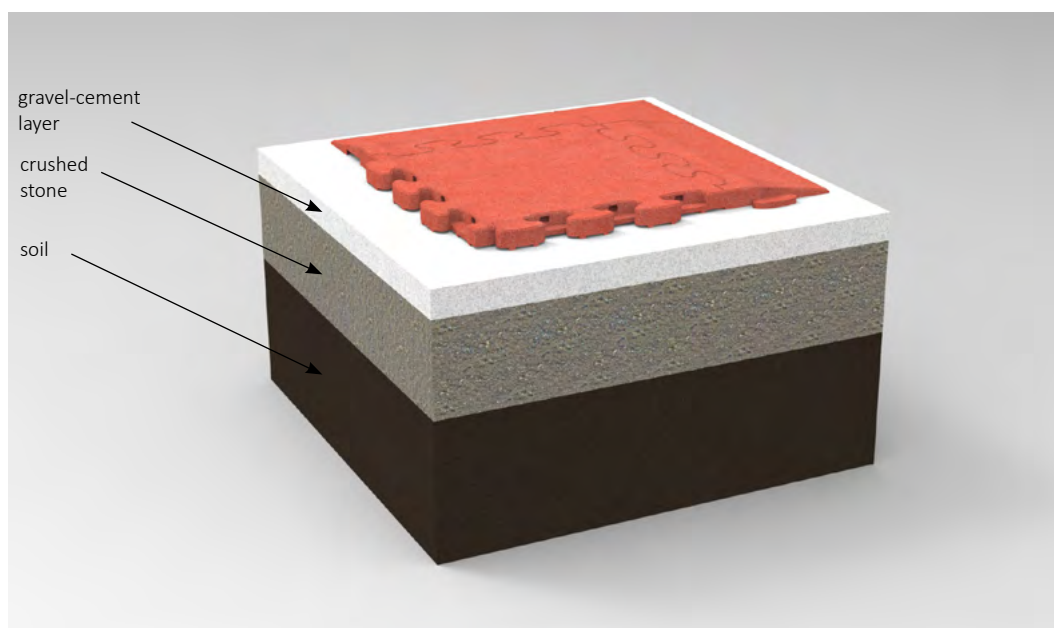

Figure 1

PUZZLE MAT 3D - INSTALLATION GUIDE

II. Installing the tiles

When laying the fall protection tiles, the puzzle elements shown in Figure 2 must be placed on the intermediate elements and the buttons pressed into the button indentations.

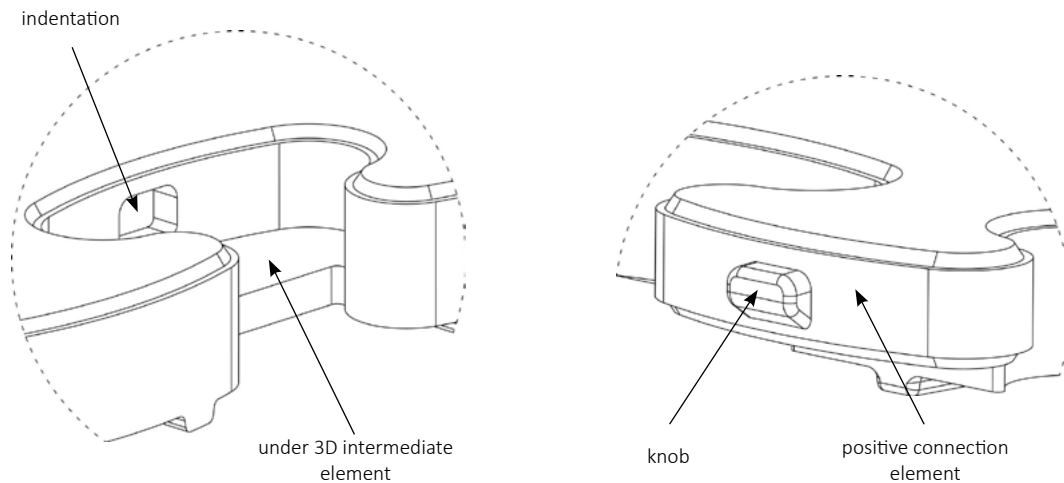

Figure 2



Figure 3

PUZZLE MAT 3D - INSTALLATION GUIDE



Figure 4

When laying the fall protection plates, you have to start in the right order, the respective steps can be carried out as shown in Figure 5:

- the corner elements marked with 3 are connected to the edge elements marked with 2;
- in the next step, the fall protection tiles marked with 1 are linked together;
- we have the sides with the same properties marked respectively with the letter “a” in green and with the letter “b” in blue;
- the different sides are put together. The puzzle elements with positive connections are linked to the intermediate elements with negative connections
- after the puzzle elements have been connected to each other, the surface has to be closed off with edge and corner elements.
- for example, the tiles marked with 1 can be linked to the respective edge tiles with both their green and their blue sides. When plugging the blue sides together, make sure that the intermediate elements of the edge elements marked red are cut out with a cutter knife beforehand (Figure 6).

PUZZLE MAT 3D - INSTALLATION GUIDE

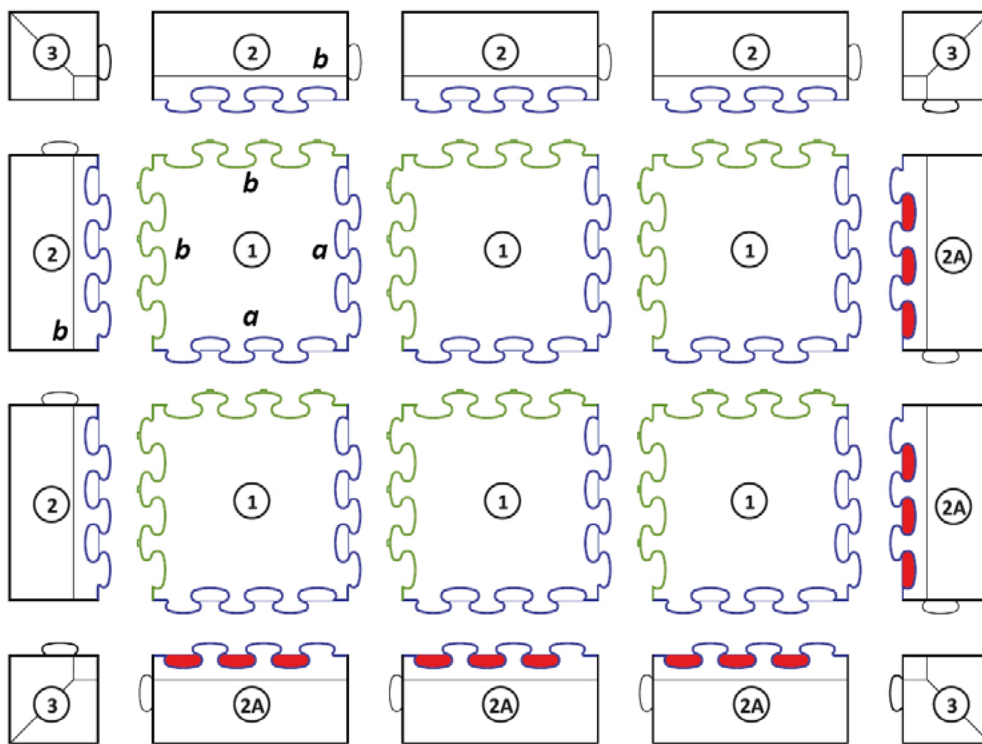
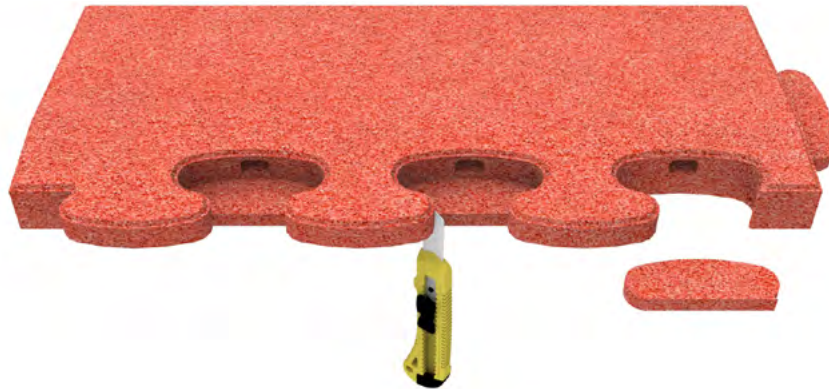

Figure 5

- ① Puzzle Mat 3D fall protection tile
- ②A Edge element with intermediate element to be cut out
- ② Edge element with intermediate element
- ③ Corner element

PUZZLE MAT 3D - INSTALLATION GUIDE*Figure 6*

In order to prevent the intermediate elements of the Puzzle Mat 3D fall protection tiles from facing each other, the tiles should generally be laid as shown in Figure 7.

wrong connection

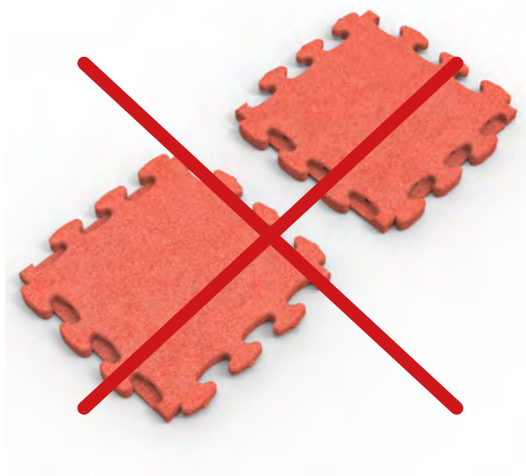

right connection

*Figure 7*

PUZZLE MAT 3D - INSTALLATION GUIDE

III. Special dimensions

In the case of individual square meter specifications, special dimensions or when edging the playground equipment, the individual tiles can be cut to size with a jigsaw (Figure 8).



Figure 8

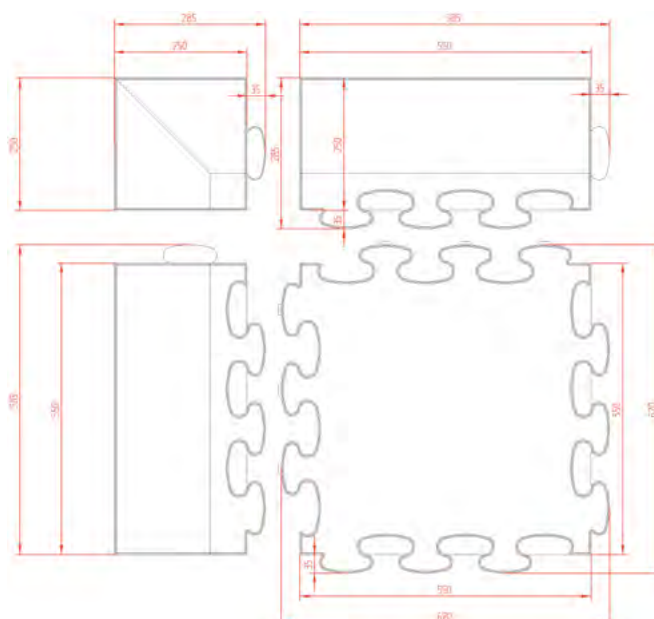

Figure 9

PUZZLE MAT 3D - INSTALLATION GUIDE

IV. MAINTENANCE

It is recommended to clean the surfaces of the rubber tiles with a broom or with a water jet to be carried out once a week with not too much pressure.

If the surface becomes dirty (e.g. due to spilled liquid), it is recommended to clean the floor with a floor cleaning machine (wet).

If the rubber floor is heavily soiled, a neutral cleaning agent or disinfectant can also be used. When using these chemicals, however, it should be noted that the chemicals should be used only in a small amount and they should touch the surface for a short time.

The rubber tiles mechanically damaged during use must be replaced as soon as possible in order to avoid accidents.

When replacing a part, the tile has to be levered out with a screwdriver.

The tiles can be disposed according to the legal regulations of the country concerned. Find out more about this at an approved waste disposal company or via your local authority.